

DEVELOPING A NEW POWERED SEED DELIVERY SYSTEM WITH CONSTANT SEED  
RELEASE SPEED USING TWO CONFRONTING BELTS

A Thesis  
Submitted to the Graduate Faculty  
of the  
North Dakota State University  
of Agriculture and Applied Science

By  
Mojtaba Ahmadi

In Partial Fulfillment of the Requirements  
for the Degree of  
MASTER OF SCIENCE

Major Department:  
Agricultural and Biosystems Engineering

June 2017

Fargo, North Dakota

North Dakota State University  
Graduate School

---

**Title**

DEVELOPING A NEW POWERED SEED DELIVERY SYSTEM WITH  
CONSTANT SEED RELEASE SPEED USING TWO CONFRONTING  
BELTS

---

**By**

Mojtaba Ahmadi

---

The Supervisory Committee certifies that this *disquisition* complies with North Dakota  
State University's regulations and meets the accepted standards for the degree of

**MASTER OF SCIENCE**

SUPERVISORY COMMITTEE:

Dr. Ganesh C. Bora

---

Chair

Mr. John F. Nowatzki

---

Dr. Thomas A. Bon

---

Dr. Hans Kandel

---

Approved:

02/20/2018

---

Date

Dr. Sreekala Bajwa

---

Department Chair

## ABSTRACT

Seed delivery devices are aimed to carry seeds down to open furrow that might affect uniformity of plant stand and spacing. The objective of this study was to develop and evaluate a new seed delivery system utilizing a two-belt mechanism configuration for sunflower (*Helianthus annuus*). A prototype were fabricated and tested with MeterMax® Ultra Test Stand in order to evaluate the new seed delivery system. The outcomes show that dependent variables like seed population, singulation, skips, and multiples rates were not affected by planting speed levels (P-values  $> 0.05$ ), while planting speed had a negative effect on seed spacing consistency (P-values  $< 0.05$ ). In addition, due to facing broken seeds during test process, multiples rate were between 8.0 to 9.5% and consequently affected other variables as well. To improve this mechanism and avoid the systematic error that caused by broken seeds, this system should be redesigned in a single-belt form.

## ACKNOWLEDGEMENTS

I would like to express sincere appreciation to Dr. Ganesh C. Bora for his guidance, insight, and patience throughout my course work and research.

Special thanks go to Mr. John F. Nowatzki, Dr. Thomas A. Bon, and Dr. Hans J. Kandel for their advice on my research as members of the supervisory committee. In addition to their academic advice, they provided me great academic experiences in study and research in this institution. I would also like to acknowledge that all of this academic experience will be a great asset in my life as an engineer.

I am also grateful to all professors, staffs, and students in Agricultural and Biosystems Engineering Department at North Dakota State University, specially Mrs. Melanie Ziegler and Mr. James Moos, who have helped and inspired me during my study and research.

I sincerely thank my family and friends, specially Dr. Mohammedmehdi Maharlooei, for their patience and faith in me.

## **DEDICATION**

I would love to dedicate this thesis to my parents, who supported me during every stage of my life and spent their whole life for my happiness and success.

## TABLE OF CONTENTS

ABSTRACT.....	iii
ACKNOWLEDGEMENTS.....	iv
DEDICATION.....	v
LIST OF TABLES.....	viii
LIST OF FIGURES.....	ix
LIST OF APPENDIX TABLES.....	xi
LIST OF APPENDIX FIGURES.....	xii
1. INTRODUCTION.....	1
1.1. Objective.....	2
2. LITERATURE REVIEW.....	3
2.1. Precision Planting Devices.....	4
2.2. Gravity Drop System.....	6
2.3. Power Drop System.....	7
3. MATERIALS AND METHODS.....	12
3.1. Design Concept of Seed Delivery Device with Two Confronting Belts.....	12
3.2. Prototype of Seed Delivery Device with Two Confronting Belts.....	13
3.2.1. Prototype Parts and Components.....	14
3.2.2. Power Source and Transmission.....	17
3.2.3. Stand Structure.....	21
3.3. Lab Tests.....	23
3.3.1. MeterMax <sup>®</sup> Ultra Test Stand.....	23
3.3.2. Lab Test Criteria.....	27
3.3.3. Calibration Test with Seed Tube.....	28
3.3.4. Testing the New Seed Delivery System.....	29

4. RESULTS .....	31
4.1. Seed Tube Calibration Results .....	31
4.2. Seed Tube Evaluation.....	32
4.3. New Seed Delivery System Evaluation .....	37
4.4. New Seed Delivery System vs. Seed Tube .....	42
5. DISCUSSION .....	48
6. CONCLUSION.....	50
7. RECOMMENDATIONS FOR FUTURE STUDIES .....	51
REFERENCES .....	52
APPENDIX.....	55

## LIST OF TABLES

<u>Table</u>	<u>Page</u>
1. Planting speed, angular velocity and rotational speed. ....	18
2. Planting speed, rotational speed, stepper motor speed, and lower and upper integers. ....	20
3. Specifications of sunflower seeds. ....	27
4. Calibration test treatments for seed tube. ....	28
5. Optimized treatments for seed tube. ....	29
6. Test treatments for the new seed delivery system. ....	30
7. Average seed singulation rates on calibration tests. ....	31
8. Optimized treatments for seed tube with their vacuum pressures. ....	32
9. Averages values for dependent variables of the optimized seed tube tests. ....	32
10. Test treatments for the new seed delivery system with their vacuum pressures. ....	37
11. Averages values for dependent variables of the new seed delivery system treatments tests. ....	37
12. Averages values for dependent variables of the new seed delivery system for each planting speed. ....	38
13. Seed population average values on seed tube and the new seed delivery system. ....	44
14. Singulation rate average values on seed tube and the new seed delivery system. ....	45
15. Skips and multiples rates average values on seed tube and the new seed delivery system. ....	46
16. SRI (upper and lower sensors) average values on seed tube and the new seed delivery system. ....	47



## LIST OF FIGURES

<u>Figure</u>	<u>Page</u>
1. Different types of precision seed metering devices. ....	5
2. Seed tube on a precision planter. ....	6
3. Effect of seed contact with the wall of seed tube.....	7
4. Conveyor belt mechanisms. ....	9
5. Seed slide and brush wheel mechanism.....	10
6. Brush belt seed delivery system.....	11
7. Speed tube seed delivery system.....	11
8. Design concept of seed delivery device with two confronting belts. ....	13
9. Prototype components.....	15
10. Partially assembled prototype components.....	15
11. Guiding nubs and their location. ....	16
12. Bottom tube and its top funnel shape component. ....	17
13. Motor, driver, controller. ....	19
14. Assembled prototype with its gear box.....	21
15. Stand to hold the new seed delivery system. ....	22
16. Stand with the new seed delivery system and stepper motor.....	22
17. MeterMax <sup>®</sup> ultra test stand. ....	23
18. Testing procedure of the new seed delivery system with test stand. ....	24
19. Coefficient of variation (COV).....	25
20. Locations of seed sensors.....	26
21. Seed population on seed tube evaluation. ....	33
22. Singulation rate on seed tube evaluation. ....	34
23. Skips and multiples rates on seed tube evaluation.....	35

24. SRI (middle and bottom sensors) on seed tube evaluation. ....	36
25. Seed population on the new seed delivery system evaluation. ....	39
26. Singulation rate on the new seed delivery system evaluation.....	40
27. Skips and multiples rates on the new seed delivery system evaluation. ....	41
28. SRI (top and bottom sensors) on the new seed delivery system evaluation. ....	42
29. Seed population average values on seed tube and the new seed delivery system. ....	44
30. Singulation rate average values on seed tube and the new seed delivery system.....	45
31. Skips and multiples rates average values on seed tube and the new seed delivery system. ....	46
32. SRI (upper and lower sensors) average values on seed tube and the new seed delivery system. ....	47

## LIST OF APPENDIX TABLES

<u>Table</u>	<u>Page</u>
A1. Test results of optimized treatments for seed tube.....	55
A2. Test results of treatments for the new seed delivery system.....	56

## LIST OF APPENDIX FIGURES

<u>Figure</u>	<u>Page</u>
A1. Assembly of steel body covers, 3D printed body frames, and guiding nubs.....	57
A2. Guiding nub.....	58
A3. Aluminum pulley. ....	59
A4. Bottom tube entrance. ....	60
A5. Bottom seed tube.....	61
A6. Gear set housing.....	62
A7. Gear set housing cap. ....	63
A8. Coupling assembly.....	64

## 1. INTRODUCTION

To meet the needs of the growing world population, cultivars and hybrids with higher performance have been developed, but this improvement caused a rise in seed price and consequently a need for planting precisely to avoid wasteful overplanting and thinning. Thus, planter manufacturers developed precision planters that accurately singulate seeds and place them in the furrow precisely. These precision planters are designed to obtain uniform seed spacing and constant depth in planting to improve uniform plant stand, which maximize yields and minimize costs (Yeon, 2000).

Plant spacing and plant population influence yield potential by affecting the degree of competition among plants for nutrients. To maximize crop yield, this competition should be minimized by balancing the needs of the individual plants. For some crops like sunflower (*Helianthus annuus*), plant population should be within a specific narrow range as well as have uniform plant spacing within rows, in order to obtain the optimum yield (Murray et al. 2006). Uniform plant spacing helps sunflower plants reach maximum final yield and higher seed quality by reducing their competition for available moisture, sunlight, and nutrients. Similarly, better management of weeds, insects, and diseases is possible with uniform plant spacing (Lilleboe, 2008).

Although precision planters improved plant stand conditions for some crops, seeds like sunflower are still facing issues with planting because sunflower seeds have an irregular shape and longer length, whereas manufacturers have designed their planters based on more uniform and rounded seeds like maize (*Zea mays*) (Lilleboe, 2008). Kandel (2014) and Kandel and Gulya (2016) reported plant spacing within a row as one of the main yield-limiting factors since 2002,

when the National Sunflower Association (NSA) conducted first sunflower crop survey across the major sunflower states in the United States and Manitoba, Canada.

To obtain accurate seed spacing, precision planters that meter individual seeds can be utilized for planting. Although there are several factors affecting plant spacing, the performance of the seed metering mechanism, as well as seed delivery system, play their roles to determine the final plant spacing (Kachman and Smith, 1995). Compare to seed metering devices that have been studied for many years, there are not as many studies conducted about seed delivery systems. In this regard, since producers are looking for more developments in precision planters to improve plant population and plant spacing, one of the main areas that still needs to be studied to develop more accurate planters might be seed delivery system. Improved power drop devices could have a good potential for planter developments and improvement.

### **1.1. Objective**

The objective of this project is to develop a new powered seed delivery system that utilizes a pair of belts to convey the seeds and discharge them with a constant speed, which is equal to planting speed. The mechanism will be designed, fabricated, and evaluated to determine how this method would help to improve plant population and spacing in precision planters for sunflower.

The major objectives of this project are as follow:

1. Developing a new mechanism to deliver sunflower seed.
2. Evaluating by using the “MeterMax<sup>®</sup> Ultra Test Stand”.

## 2. LITERATURE REVIEW

It has been recognized by the agricultural industry that planting operations require performing at higher speeds due to the importance of timeliness in planting operations. In planting, time plays an important role due to potential inclement weather, which allows a limited period of time for planters to perform planting operations (Kepner et al., 1978 and Radtke, 2016). However, planting at higher speeds increases seed rolling and bouncing at the moment of landing in the furrow and consequently causes poor plant placement (Radtke, 2016).

Uniform seed placement, which includes appropriate seed spacing and depth within a seed furrow, has a significant effect on maximizing the yield of a crop and therefore profitability of grower's operations. By placing the seeds at a proper spacing and depth in the furrow, the rate of germinated seeds may increase and thus more emerged plants can be expected (Breece et al., 1975 and Sauder et al., 2004). According to Smith and Kocher (2008), Kandel (2014), and Kandel and Gulya (2016), irregular plant spacing can be referred to row areas with growing plants that have skips (wide spacing) or multiples (close spacing). With lower population, sunflower plants are able to compensate for short skips by increasing the number of seeds per head and seed weight, but on the other hand, multiples cause a reduction in final yield by reducing the seed size and the number of seeds on some of the sunflower heads (Sayler, 2006). To obtain maximum sunflower crop yield with uniform seed size, especially in extra-large confection seeds, sunflower seeds should be equally distributed in the field by accurately adjusting both plant population and plant spacing. However, sunflower growers are still struggling with improving plant spacing during planting operations (Smith and Kocher, 2008 and Kandel, 2013).

In addition, the results of different researches on various plants indicate that germination and emergence rates can be affected by seed orientation at planting as well, which is conceptually

possible to control during seed placement (Bowers and Hayden, 1972; Bosy and Aarssen, 1995; Jaskani et al., 2006; Torres et al., 2011; Kevin et al., 2015). Although plant emergence is affected by different factors and planter performance is not able to control all of them, many of these factors can get influenced by the planter. Hence, to achieve an acceptable plant stand, it is necessary to employ planters with high performance, especially for crops with a potential low emergence rate (Kepner et al., 1978).

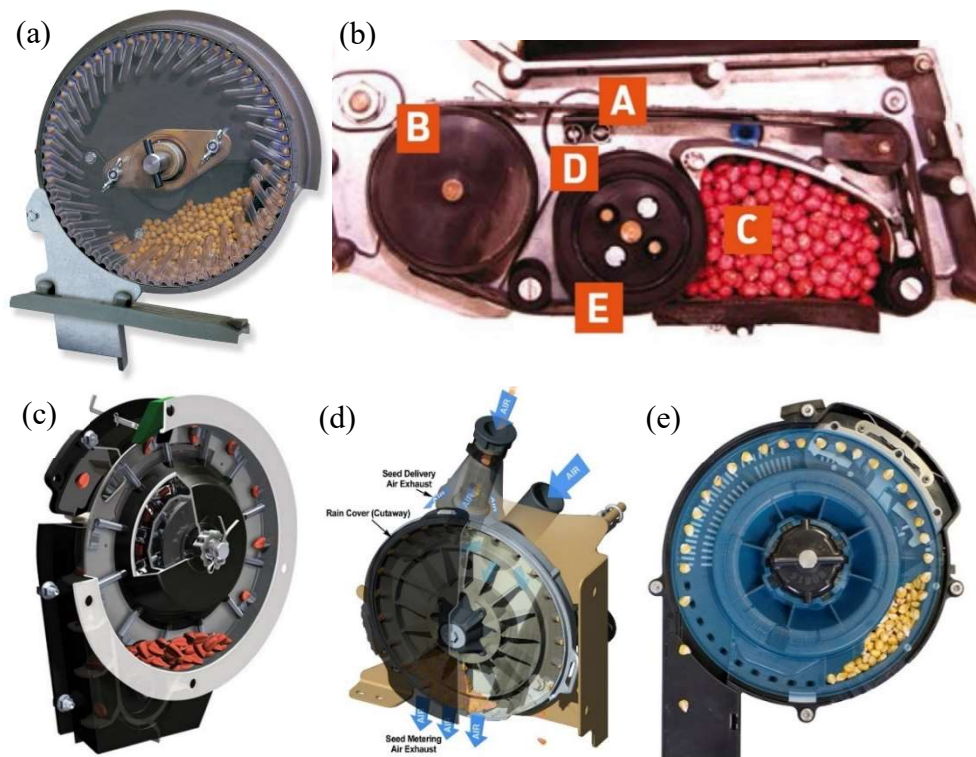
### **2.1. Precision Planting Devices**

In order to meter and place the seeds in the furrow, planters employ two systems which are in serial connection with each other, called “seed metering system” and “seed delivery system” (Garner et al., 2013 and Garner et al., 2014). In precision planters for metering individual seeds, several mechanisms have been designed to singulate the seeds and discharge them at consistent intervals, which result in desired uniformity in seed spacing (Sauder et al., 2004). These methods should be able to result in correct plant population and seed spaced uniformly regardless of different field conditions, planting speeds, seed types, and seed level in the hopper, thus it is essential to adjust the right setting and calibration on the metering unit based on the seed type and planting condition (Murray et al. 2006). Seed metering mechanisms can be categorized as mechanical or pneumatic, based on their seed selection mechanism. Some of the commercially available examples of these mechanisms are finger-pickup meters, cavity-disk meters, vacuum-type meters, and compressed air meters (Sauder et al., 2004). Figure 1 shows different types of precision seed metering devices.

Although these seed metering mechanisms use different methods for singulating seeds, all of them are mounted almost at the same location which is below the seed hopper. So, there is about 45 to 61 cm [approximately 18 to 24 inches] between the metering device discharge point to the



ground surface, and it requires planters to use a seed delivery device that is capable of translating the accuracy of seed metering to seed placement (Sauder et al., 2004; Murray et al., 2006). The seed delivery system is a mechanism that receives seeds from the seed metering device and delivers them to the open furrow at a predetermined rate to result in properly spaced planted seeds (Breece, 1975; Murray et al., 2006). Seed delivery systems can be categorized based on their delivering mechanisms in to “gravity drop system” or “power drop system” (Breece, 1975; Thiemke, 2003; Murray et al., 2006; Stephens, 2008).



**Figure 1. Different types of precision seed metering devices. (a) Cavity-disk seed meter<sup>1</sup>, (b) Belt-type seed meter<sup>2</sup>, (c) Finger-pickup seed meter<sup>3</sup>, (d) Compressed-air seed meter<sup>4</sup>, and (e) Vacuum seed meter<sup>5</sup>.**

<sup>1</sup> Kinze Manufacturing, Brush-type seed meters.

<sup>2</sup> Stanhay Webb Ltd, High precision belt planter. (A) Seedbelt, (B) Drivewheel, (C) Choke, (D) Repeller wheel, (E) Base.

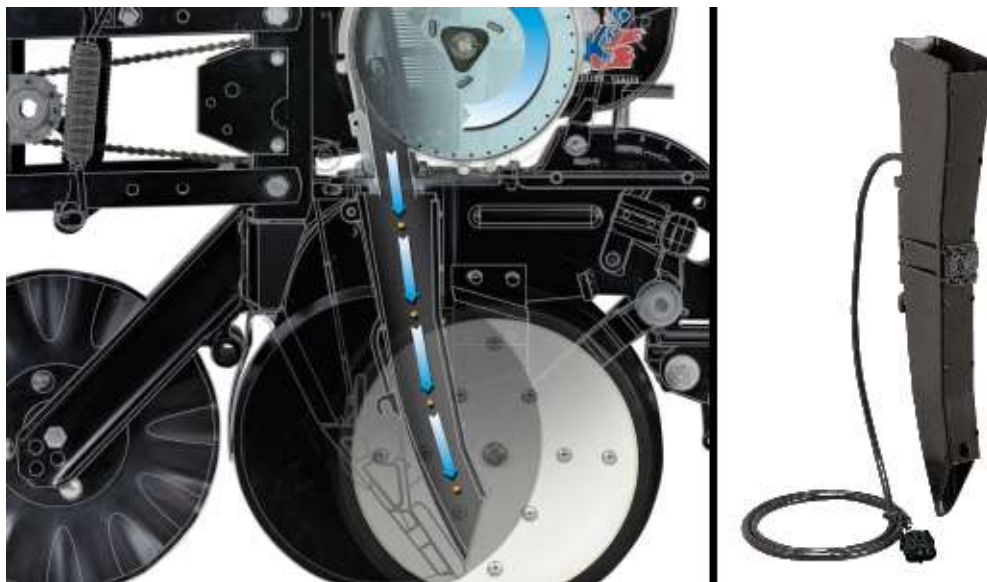
<sup>3</sup> Precision Planting, Precision meter.

<sup>4</sup> Great Plains Manufacturing, Air-Pro® meters.

<sup>5</sup> Kinze Manufacturing, 4000 Series vacuum meter.

## 2.2. Gravity Drop System

The simplest and least expensive method to deliver seeds into the furrow consists of a tube that is placed under the metering device and let the seeds fall down to the furrow, which is called a seed tube (Breece, 1975; Murray et al., 2006). In this method, singulated seeds fall from the discharge end of the metering device into the seed tube and descend to the seed furrow by gravitational force alone (Garner et al., 2013; Garner et al., 2014). Figure 2 shows a seed tube on a precision planter.



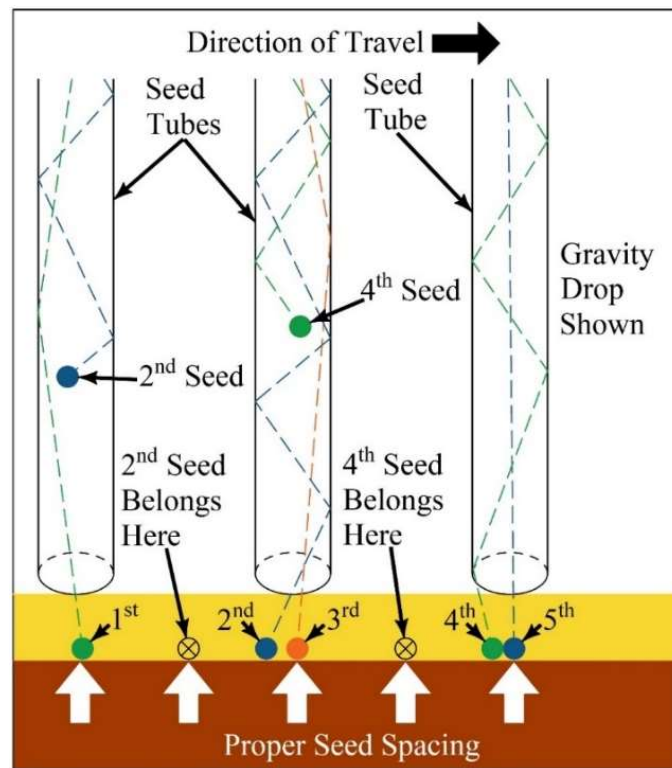
**Figure 2. Seed tube on a precision planter<sup>6</sup>. Seeds are falling down through the seed tube from a seed metering unit to the furrow.**

Although seed tubes are useful devices for guiding seeds into the furrow, they have a negative effect on seed placement uniformity. Since seeds may contact the seed tube wall as they fall down to the furrow, it affects the required time for seeds to drop, which may cause a “later-discharged” seed to drop faster than an “earlier-discharged” seed (Breece, 1975; Sauder et al., 2004). Figure 3 shows how seed contact with the seed tube wall could affect the final seed spacing.

---

<sup>6</sup> Kinze Manufacturing, Computerized smart sensor.

This problem can be related to different factors such as irregularities on the field surface and irregularities among the seeds. In addition, when seeds exit the seed tube and land on the soil, relative velocities of seeds to the ground degrade the seed spacing uniformity by tumbling and bouncing them (Sauder et al., 2004; Rans, 2015). The seed tube may employ a rearward curvature to reduce the velocity of seeds relative to the ground and consequently reduce seed bouncing. However, higher travel speeds will amplify the effect of field dynamic surface conditions, and as a result make the spacing variation worse (Garner et al., 2013; Garner et al., 2014).



**Figure 3. Effect of seed contact with the wall of seed tube<sup>7</sup>. Improper seed spacing due to using seed tube.**

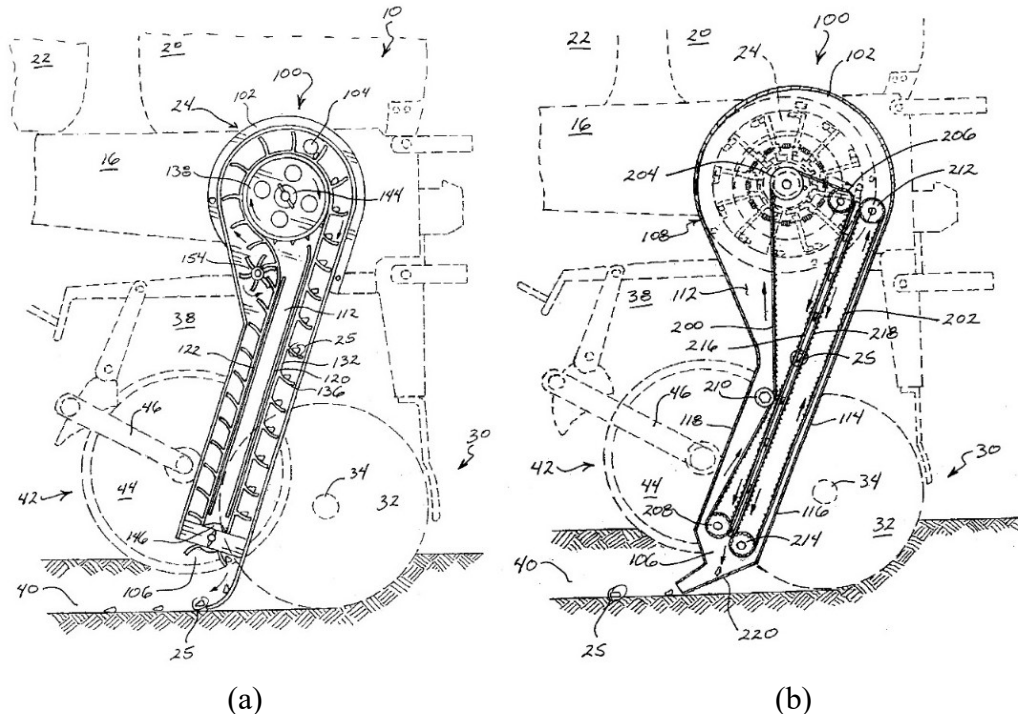
### 2.3. Power Drop System

Power drop seed delivery mechanisms have been developed to maintain desired seed spacing in the furrow as planters operate at both high and low travel speeds by effectively

<sup>7</sup> Breece et al., 1975.

controlling seeds delivery, thus increase crop yield, efficiency, and profitability of farming operations (Sauder et al., 2004; Radtke, 2016). Since gravity drop does not effectively reduce variation in seed spacing, manufacturers tried different power drop mechanisms to improve the consistency in seed spacing (Garner et al., 2013; Garner et al., 2014). In a power drop seed delivery system, there is a conveyor that carries the seed from the seed meter down to the furrow (Murray et al., 2006).

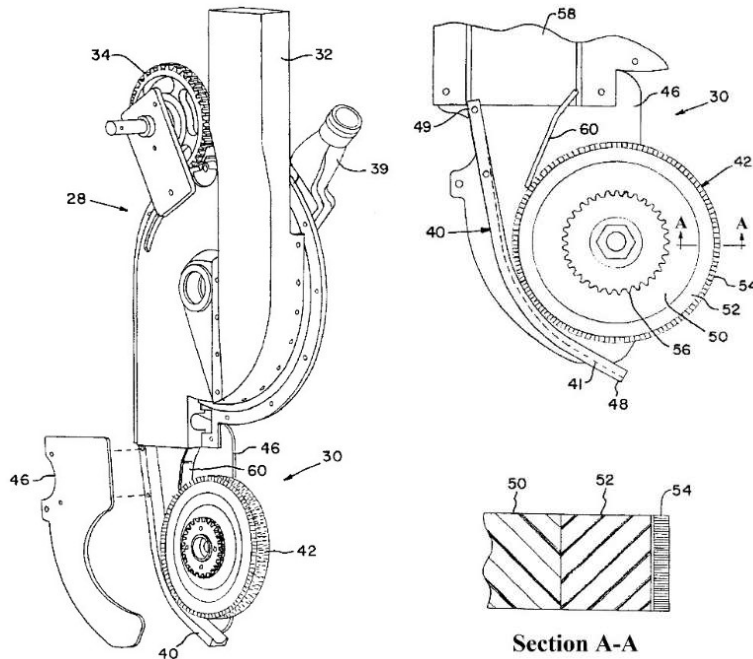
Sauder et al. (2004) designed a conveyor belt mechanism with two approaches to transport seeds from seed metering to the furrow. Figure 4 (a and b) shows both approaches of conveyor belt mechanism. The first approach includes a single endless belt with evenly spaced flights, and the second approach includes two confronting endless belts. In either form, conveyor belt(s) would be driven at a controlled speed, so that seeds would be carried and discharged at the same sequence of loading (Sauder et al., 2004; Garner et al., 2013; Garner et al., 2014). Although both approaches are able to reduce the effect of field conditions on seed spacing variability by controlling the seeds travel path and speed, neither of them are able to reduce the relative horizontal velocity of seeds to the ground close to zero (Garner et al., 2013; Garner et al., 2014).



**Figure 4. Conveyor belt mechanisms<sup>8</sup>. Two approaches of conveyor belt mechanisms for seed delivery system in precision planters. (a) Single belt configuration and (b) two confronting belts formation.**

In a hybrid mechanism, a seed slide and a brush wheel have been used for seed delivery. As shown in Figure 5, seeds descend from seed meter to the brush wheel through the seed slide and then they are accelerated by a brush wheel to reach the horizontal velocity equal to the planter travel speed but in the opposite direction. In this way, the relative velocity of seeds to the ground is very low or zero (Thiemke, 2003; Stephens, 2008; Garner et al., 2013; Garner et al., 2014). Even though this mechanism can reduce the horizontal velocity of seeds relative to the ground, the weakness of this system is the seed slide part, which is a gravity drop and causes inconsistency in seed spacing (Garner et al., 2013; Garner et al., 2014).

<sup>8</sup> Sauder et al., 2004.



**Figure 5. Seed slide and brush wheel mechanism<sup>9</sup>. A seed delivery mechanism utilizing seed slide and brush wheel. The complete mechanism is on the left side of the figure and its side view is on the right side.**

To avoid the effect of gravity, manufacturers tried to focus on belt delivery systems that are more accurate in maintaining the uniformity of seed spacing regardless of planter speed (Li et al., 2016). In this regard, two mechanisms have been developed by two major agricultural machinery manufacturers. One of them is called “Brush Belt”, which is a John Deere Inc. product that uses a brush belt, and the other design is related to Precision Planting Inc., which is called “Speed Tube” and employs a flighted belt. These two seed delivery mechanisms are shown in Figures 6 and 7. In both mechanisms, seeds would be captured by the belt from seed metering, moved down near the furrow, and at the exit point accelerated to reach low or zero horizontal velocity relative to the ground (Garner et al., 2013; Garner et al., 2014; Radtke, 2016; Li et al., 2016). These two mechanisms, which are similar to each other, are able to perform at higher planting speeds while maintaining the desired seed spacing (Li et al., 2016).

<sup>9</sup> Thiemke, 2003.

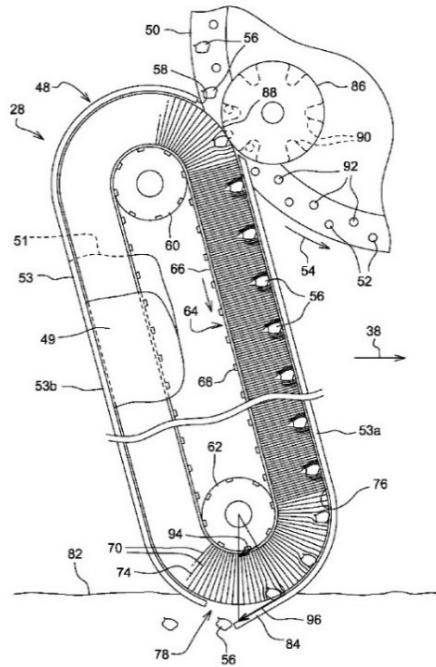


Figure 6. Brush belt seed delivery system<sup>10</sup>.

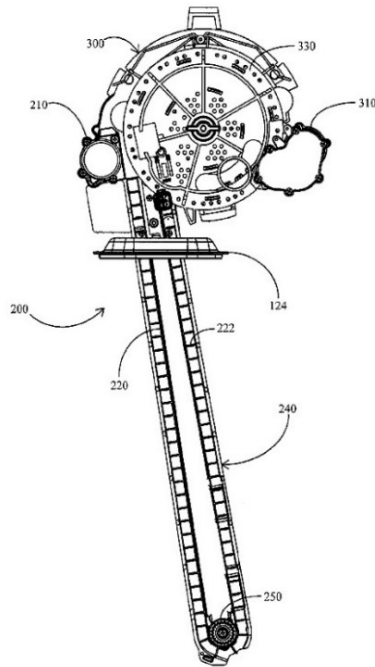


Figure 7. Speed tube seed delivery system<sup>11</sup>.

<sup>10</sup> Garner et al., 2014.

<sup>11</sup> Radtke, 2016.

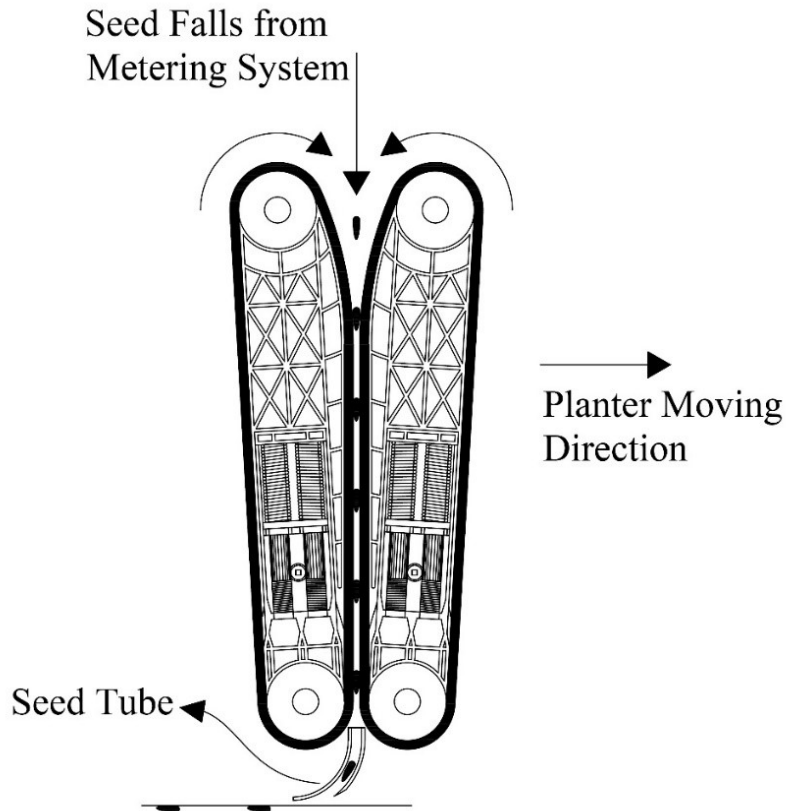
### **3. MATERIALS AND METHODS**

In this section, different steps for designing, prototyping, and testing a new seed delivery device with two confronting belts are presented.

#### **3.1. Design Concept of Seed Delivery Device with Two Confronting Belts**

To avoid seeds rolling and bouncing in the furrow, they should reach approximately zero horizontal velocity relative to the ground when they contact the soil. Existing seed delivery mechanisms accelerate seeds at the release point to counteract the speed from planter. Unlike these current seed delivery mechanisms, the main idea behind our new design is to carry seeds from metering device to the furrow with constant speed. In this regard, to avoid the effect of planter speed and field surface condition, a seed delivery mechanism was designed to grab and hold the seeds securely with two confronting rubber belts from the metering device. Then seeds are carried down vertically to the bottom end of the belts and dropped into a small curved tube to change the direction of motion on seeds from vertical to horizontal before releasing them into the furrow. Since there are two belts running in this device for transferring the seeds, they should run at the same speed but in opposite rotational directions. In this way, belts would not wear each other or damage the seeds while transporting them. In addition, these two belts should be driven as fast as the planter speed to provide the required speed on the seeds at the discharge point. Figure 8 shows the mechanism of the designed seed delivery device.





**Figure 8. Design concept of seed delivery device with two confronting belts.**

In addition, there are two guiding nubs in this design, which are located in the seed path at both sides of the belts, to smoothly guide the seeds while they are moving down and adjust the orientation of seeds in order to get them all aligned on their path to the furrow. This adjustment removes the effect of seed size and shape on the seed delivery system and improves seed to soil contact. Moreover, adjusting the orientation of seeds makes it possible to use a narrower and more accurate tube at the discharge point.

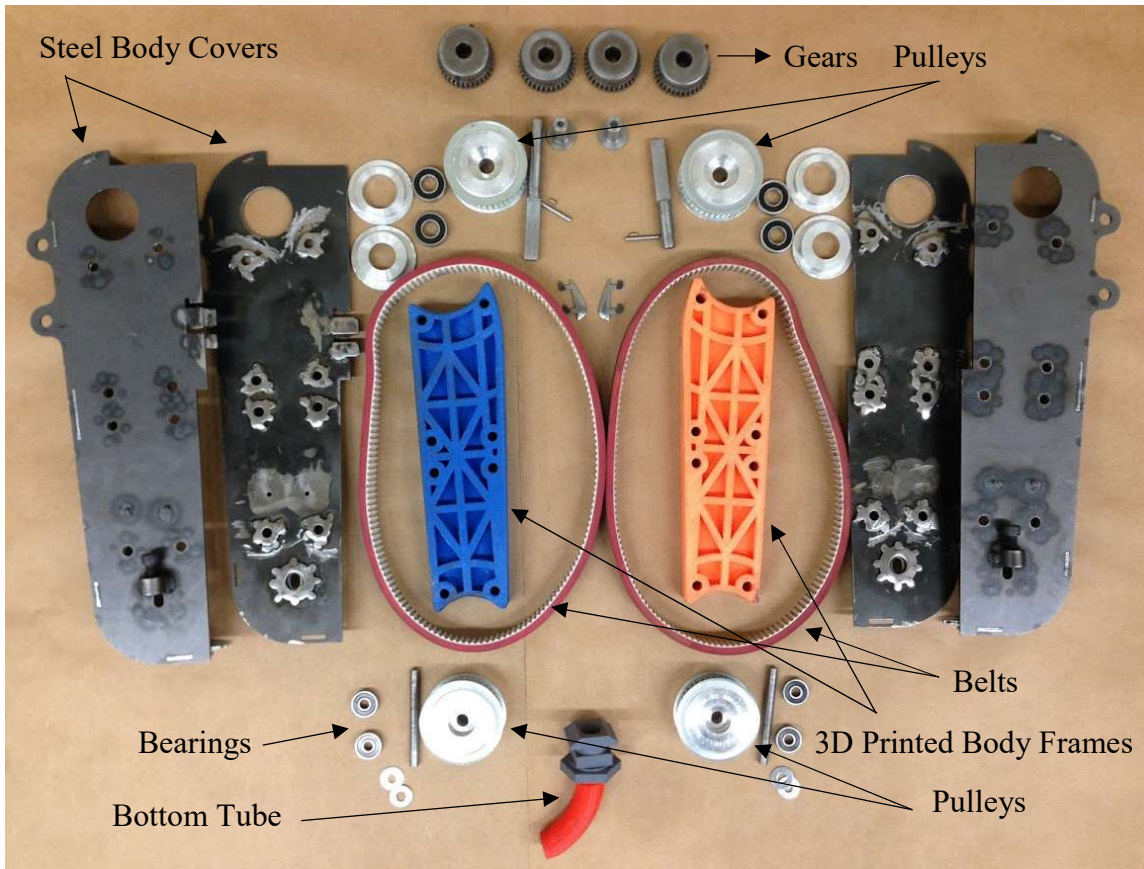
### **3.2. Prototype of Seed Delivery Device with Two Confronting Belts**

A prototype seed delivery device with two confronting belts was designed and fabricated in three major phases: prototype parts and components; power source and transmission; and stand structure.

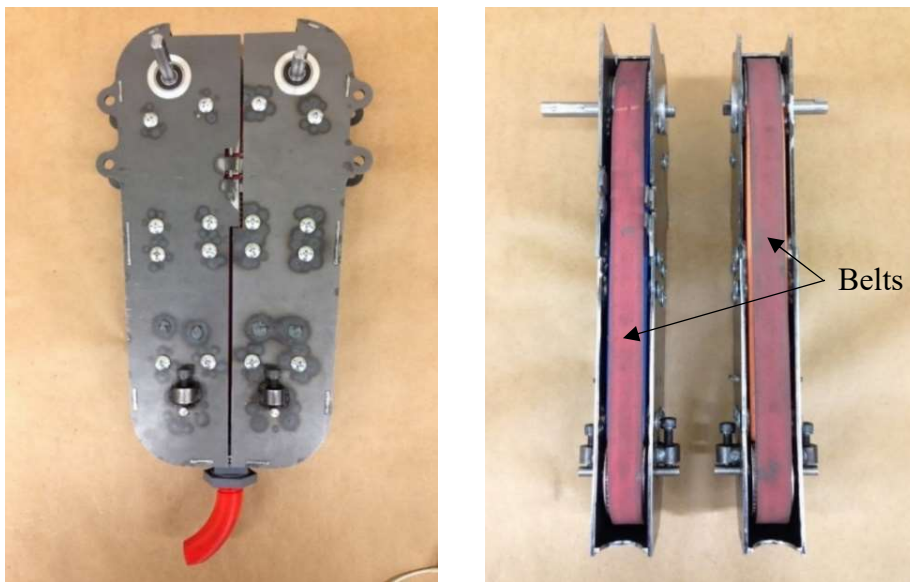
### 3.2.1. Prototype Parts and Components

In this design, the main components are the two confronting belts. Based on the application of these belts to carry the seeds from metering device to the furrow, they should have a high coefficient of friction to hold them securely, as well as being soft and flexible enough to avoid applying any extra pressure on the seed shell. In addition, using a timing belt makes it possible to run this system without any slippage on pulleys, which makes it more promising to run the belts with constant speed. By considering these requirements, a pair of timing belts with durable Linatex back cover material was chosen to carry the seeds due to its high coefficient of friction and flexibility (BRECOflex Co., 2003). The specification of the belts was as: Polyurethane belts with Kevlar tension members, spliced and welded endless, 25 mm width, T5 pitch, 815 mm length, 6 mm thick Red Linatex back cover.

After finalizing belts and their pulleys, the next step was designing body frames and covers to form the running path for belts and hold all the parts on their places including pulleys and guiding nubs. Body frames were to bring the running belts close to each other until they can hold the seeds between them and this spacing should be maintained to the bottom end of the belts. To build these parts, body frames were fabricated by 3D printing with PLA filaments to benefit light weight and high strength, and body covers pieces were cut out of steel sheet with laser and welded together. Figures 9 and 10 show the partially assembled prototype and its components.

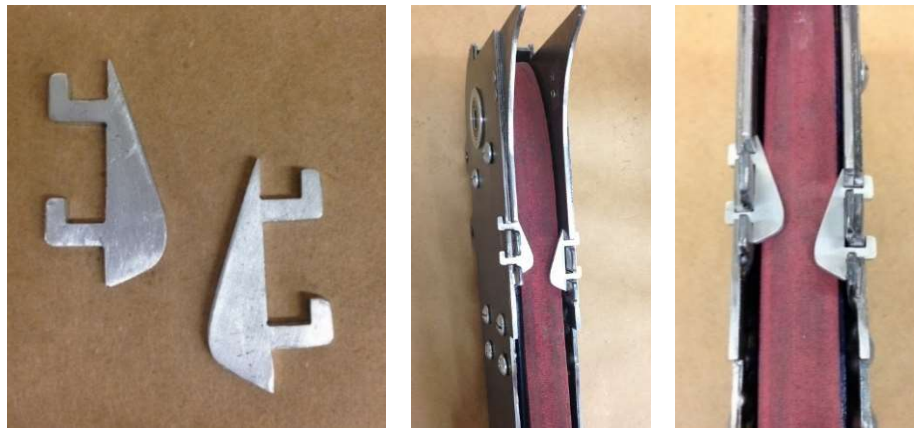


**Figure 9. Prototype components.** This picture shows belts and pulleys, steel body covers, 3D printed body frames, bottom tube, gears, shafts, bearings and fasteners.



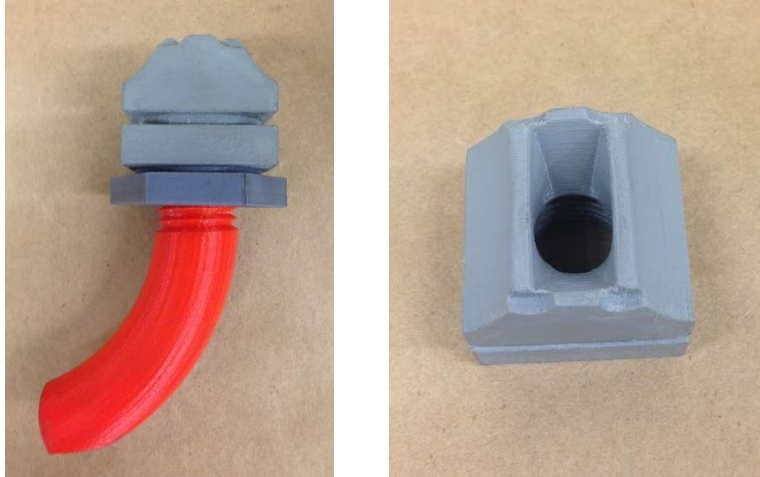
**Figure 10. Partially assembled prototype components.** Left one is front view of the assembled components and right one is the assembled components from belts view.

To have a better seed to soil contact and being able to use a narrow tube at the bottom side of the seed delivery device, two small guiding nubs were designed to align all the seeds and adjust their orientations while they were carried down by the belts (Figure 11). These guiding nubs are placed on either side of the covers, one after the other one, and make sure misaligned seeds are straightened out. Since these two nubs would be rubbed by the belts, they were made of aluminum for a better heat transfer compare to steel.



**Figure 11. Guiding nubs and their location. Left picture shows the guiding nubs. Right and centered pictures show their location.**

At the bottom of this prototype where seeds are released from the belts, there is a small narrow tube that has a curvature to change the direction of motion on seeds (Figure 12). This curvature takes seeds in vertically and passes them out horizontally, which makes them ready to get placed into the open furrow.



**Figure 12. Bottom tube and its top funnel shape component. Left picture shows bottom tube assembly and the right one shows its top funnel shape component.**

### 3.2.2. Power Source and Transmission

To run this system during the lab tests six different speed levels were determined: 8.2, 9.7, 11.1, 12.7, 14.2, and 16.4 km h<sup>-1</sup> [5.1, 6.0, 6.9, 7.9, 8.8, and 10.2 mph]. To calculate the required angular velocity to run the pulleys and belts the following formula was employed.

$$\omega = \frac{v}{r} \quad (1)$$

where,

$\omega$  : Angular Velocity (rad min<sup>-1</sup>),

$v$  : Linear Velocity on the belt surface (km h<sup>-1</sup>);  $8.2 \leq v \leq 16.4$ ,

$r$  : Radius from the center of pulley to the belt surface (mm);  $r = 38.1$  mm [1.5 in].

The value of linear velocity on the surface of the belts were equal to the planting speed, due to having zero horizontal velocity on the seeds relative to the ground at the discharge point. To find the required speed range of motor to run this device, the values of rotational speed  $N$  (rpm) were calculated by dividing the values of angular velocity  $\omega$  (rad min<sup>-1</sup>) by  $2\pi$  (rad rev<sup>-1</sup>) as it shows in Table 1.

**Table 1. Planting speed, angular velocity and rotational speed.**

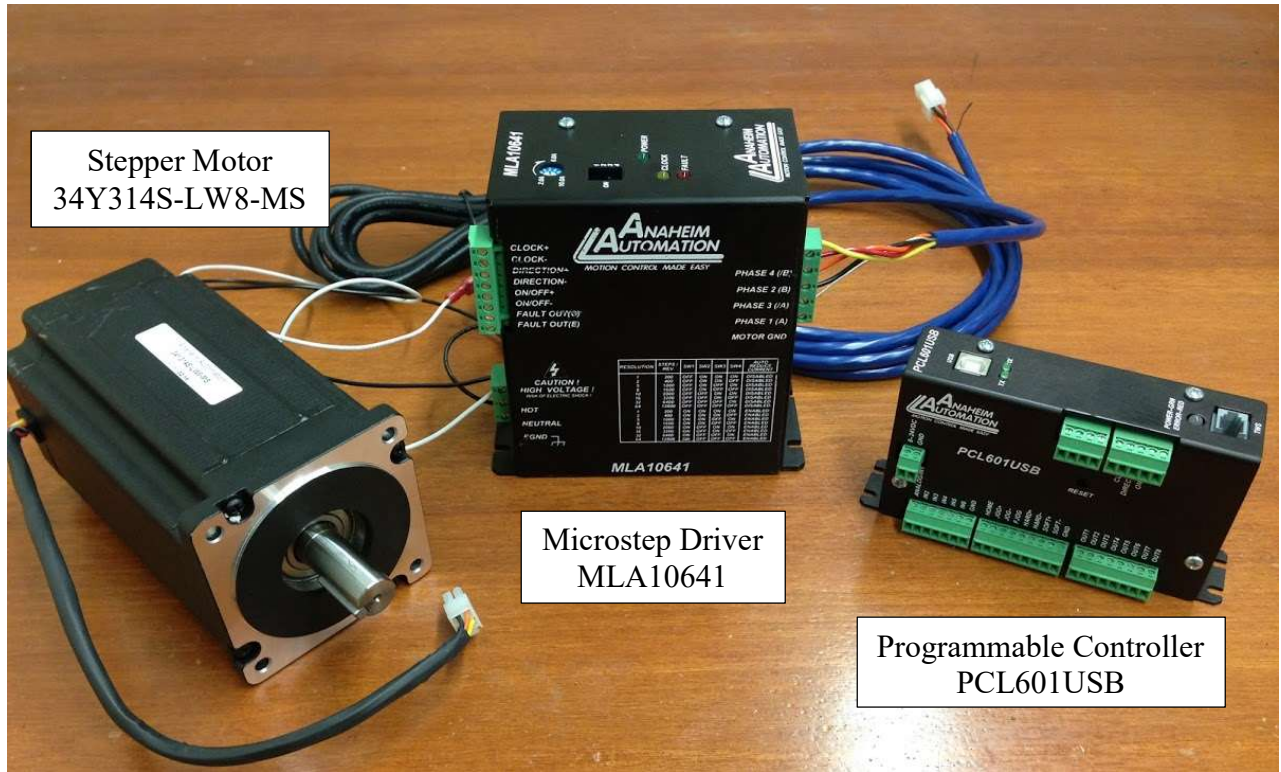
$v$ , Planting Speed (km h <sup>-1</sup> ) [mph]	$\omega$ , Angular Velocity (rad min <sup>-1</sup> )	$N$ , Rotational Speed (rpm)
8.2 [5.1]	3,590.4	571.43
9.7 [6.0]	4,224.0	672.27
11.1 [6.9]	4,857.6	773.11
12.7 [7.9]	5,561.6	885.16
14.2 [8.8]	6,195.2	986.00
16.4 [10.2]	7,180.8	1,142.86

These numbers show that to run this system, it is required to have a motor with variable speed range and able to run at least up to about 1,150 rpm. In addition to the operating speed, the amount of required torque to run these belts is important for sizing a motor to run this system; 3.2 N.m torque was required to run each of these belts for the total required torque of 6.4 N.m.

### **3.2.2.1. Power source**

A stepper motor was selected since they have a lower price, high torque, a wide range of rotational speeds, and reliability. However, it is required to have a driver and controller for running the stepper motor and adjusting its rotational speed. The motor (model: 34Y314S-LW8-MS) is a high-torque stepper motor from Anaheim Automation, Anaheim, CA. Figure 13 shows the stepper motor and its driver and controller. This motor has a NEMA 34 frame size, 12.0 N.m [1,700 oz-in] holding torque, and runs up to 50 rps (3,000 rpm) according to its specifications and test graphs (Anaheim Automation, n.d.). A Microstep Driver (model: MLA10641) and a Programmable Controller (model: PCL601USB) (Anaheim Automation, n.d.) were used to run the motor and adjust its velocity. The Microstep Driver has a high torque output, 200 to 12,800 steps rev<sup>-1</sup>, 2.0 to 10.0 Amps output current capacity, 90 to 132 Volts AC input voltage, etc. (Anaheim Automation, n.d.). The Programmable Controller has easy to use windows software, 24 Volts compatible inputs, Multi-drop capabilities, etc. (Anaheim Automation, n.d.).





**Figure 13. Motor, driver, controller. From left to right: High-torque stepper motor, microstep driver, and programmable stepper motor controller.**

Based on the specifications of this stepper motor and driver, 200 steps  $\text{rev}^{-1}$  were selected to calculate the stepper motor speed (steps  $\text{sec}^{-1}$ ) as shown in Table 2 by using the following formula (Anaheim Automation, n.d.).

$$n \left( \frac{\text{steps}}{\text{sec}} \right) = N \left( \frac{\text{rev}}{\text{min}} \right) \times 200 \left( \frac{\text{steps}}{\text{rev}} \right) \times \frac{1}{60} \left( \frac{\text{min}}{\text{sec}} \right) \quad (2)$$

where,

$n$  : Stepper Motor Speed (steps  $\text{sec}^{-1}$ ),

$N$  : Rotational Speed (rpm).

Although these values show the required stepper motor speed to reach the desired planting speed, the controller of this stepper motor only accepts integer values. Therefore, the stepper motor was run with both lower and upper integers of the calculated values.

**Table 2. Planting speed, rotational speed, stepper motor speed, and lower and upper integers.**

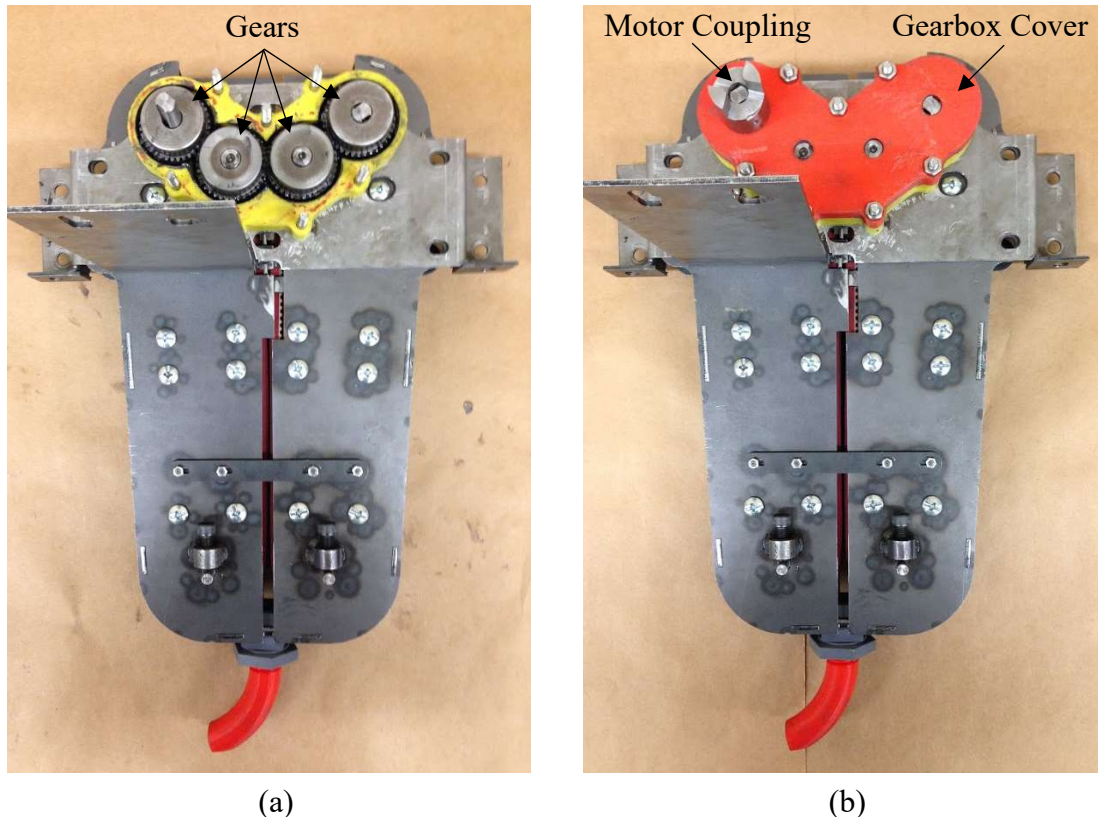
$v$ , Planting Speed (km h <sup>-1</sup> ) [mph]	$N$ , Rotational Speed (rpm)	$n$ , Stepper Motor Speed (steps sec <sup>-1</sup> )	Lower Integer (steps sec <sup>-1</sup> )
			Upper Integer (steps sec <sup>-1</sup> )
8.2 [5.1]	571.43	1,904.77	1,904
			1,905
9.7 [6.0]	672.27	2,240.90	2,240
			2,241
11.1 [6.9]	773.11	2,577.04	2,577
			2,578
12.7 [7.9]	885.16	2,950.52	2,950
			2,951
14.2 [8.8]	986.00	3,286.66	3,286
			3,287
16.4 [10.2]	1,142.86	3,809.53	3,809
			3,810

Lower and upper integers were used for running the stepper motor instead of calculated values.

### 3.2.2.2. Power transmission

To carry the seeds without damaging them, both belts should be driven at the same speed but in opposite rotational directions. Both belts are connected to the power source by a gear set that connects the shafts of both pulleys to each other (Figure 14). Since these two shafts were going to turn at the same speed in opposite directions, they were connected together by using two spur gears with the same size. Due to the space limitation and weight reduction, four smaller gears were used instead of two large gears. This combination reduced the total weight of gears and amount of applied tension on each shaft due to the gear weight.





**Figure 14. Assembled prototype with its gear box. These pictures show (a) gears and back cover of gear box are added to the prototype and (b) the front cover of gear box and one side of the coupling to the motor is added as well.**

### 3.2.3. Stand Structure

A stand was built to hold the new seed delivery system and electric motor connected to each other for the lab tests with a test stand (Figure 15 and 16). This stand was made by cutting and bending the pieces out of steel sheets then welding and bolting them together.



**Figure 15. Stand to hold the new seed delivery system.**



**Figure 16. Stand with the new seed delivery system and stepper motor.**

### 3.3. Lab Tests

#### 3.3.1. MeterMax<sup>®</sup> Ultra Test Stand

The new seed delivery system was evaluated with a MeterMax<sup>®</sup> Ultra Test Stand (Precision Planting<sup>®</sup>, Tremont, IL). Figures 17 and 18 show the MeterMax<sup>®</sup> Ultra Test Stand and testing procedure of the new seed delivery system. MeterMax<sup>®</sup> Ultra Test Stand allows meters to plant at the highest performance by calibrating them to the planting seeds, speed, spacing, and population (Uittenbogaard, 2015; Precision Planting, 2017). This test stand utilizes a 20/20 SeedSense<sup>™</sup> planter monitor, which gathers raw information from the seed sensors on the seed tubes and processes it into more valuable information like seed population, singulation rate, skips, multiples, and coefficient of variation in seed spacing (Precision Ag Solutions, 2017).

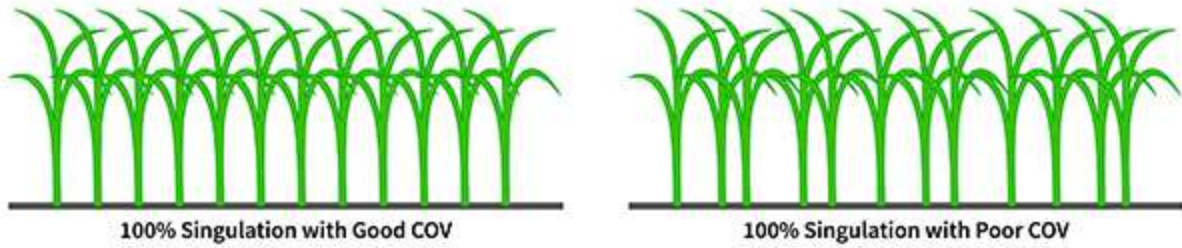


Figure 17. MeterMax<sup>®</sup> ultra test stand.



**Figure 18. Testing procedure of the new seed delivery system with test stand. This picture shows the new seed delivery system test procedure with test stand.**

During the lab tests, to measure the performance of seed metering device and the new seed delivery system, planting speed and vacuum pressure were set as independent variables to monitor their effect on dependent variables while setting other parameters fixed during the whole tests. Fixed parameters in those tests were including meter type, seed, target seed population, and row spacing. Dependent variables were actual seed population, singulation rate, skips, multiples, and seed release index (SRI). Seed population, which indicates seed distribution in the field, and singulation rate are measurements of seed metering device performance, while seed release index (or coefficient of variation in seed spacing) can be used to evaluate the overall performance of planter (Figure 19) (Dykstra, 2016; Precision Planting, 2017).



**Figure 19. Coefficient of variation (COV)<sup>12</sup>. COV is the measurement of variation in seed spacing.**

Uniformity of seed spacing is measured by SRI, which is computed by dividing the standard deviation of seed spacing by the average seed spacing (Precision Planting, 2017):

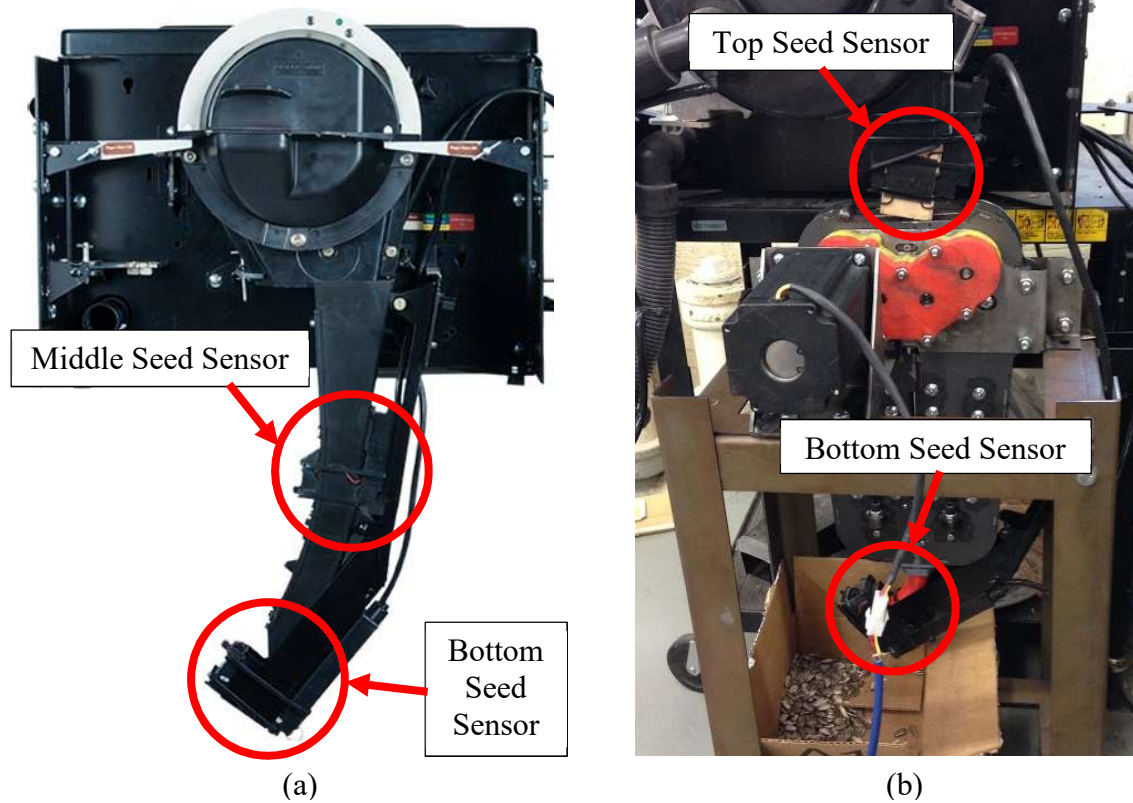
$$\text{SRI} \equiv \text{COV} = \frac{\text{Standard derivation of seed spacing}}{\text{Average seed spacing}} \quad (3)$$

The normal range for SRI is between 5 to 12 percent, and a lower number indicates more uniformity on seed spacing. Since there are two seed sensors on this test stand, SRI is calculated for both seed sensors. On the seed tube, these sensors are located one at the middle and one at the bottom of the seed tube; on the new seed delivery system, these sensors are located on at the top and one at the bottom of the new seed delivery system (Figure 20).

---

<sup>12</sup> Dykstra, 2016





**Figure 20. Locations of seed sensors. These pictures show (a) seed sensors on a seed tube<sup>13</sup> and (b) seed sensors on the new seed delivery system.**

These seed sensors are using a light source and a light responsive element, which are positioned along seeds travel path, measuring an electrical pulse as a seed passes through the sensor (Steffen, 1985; Srivastava et al., 2006). In addition to determining the seed population, singulation rate and SRI, these seed sensors are able to identify skips and multiples. Skip can be referred to the percentage of seed spacings that are greater than 1.5 times the desired spacing, while multiple is referred to the percentage of seed spacings that are less than or equal to half of the desired spacing (Smith et al., 2008).

<sup>13</sup> Pruemer Precision, 2016

### 3.3.2. Lab Test Criteria

During the lab test, eSet<sup>®</sup> vacuum meter (Precision Planting<sup>®</sup>, Tremont, IL) was used as the metering device. Extra-large confection sunflower seeds were used for this experiment, since plant stand has been a major issue for sunflower. For all tests, one batch of seeds were used and cleaned over and over. To determine the specifications of this hybrid of sunflower seed, a sample of 100 seeds were selected from the whole batch to measure different parameters of them (Table 3).

**Table 3. Specifications of sunflower seeds.**

Parameter	Average (in 100 seeds)	Standard Deviation (in 100 seeds)
Length (mm)	17.80	0.80
Width (mm)	10.09	0.28
Thickness (mm)	5.30	0.45
Weight (g)	0.20	0.01

Total weight for 100 seeds were 20.0 grams.

Target seed population (seeding rate) and row spacing were set on 43,243 seeds per hectare [17,500 seeds per acre] and 55.9 cm [22 in.], respectively (Randy Klassen, RDK Enterprises, personal communication, 2016). Since seeds were metered individually with the test stand, the seed spacing along the row can be calculated as 41.4 cm [16.3 in.] by using the following formula (Srivastava et al., 2006):

$$\text{Seed spacing (m)} = \frac{10,000}{\text{Row spacing (m)} \times \text{Seed population} \left( \frac{\text{seeds}}{\text{ha}} \right)} \quad (4)$$

For planting speed, 6 different speed levels were used that were 8.2, 9.7, 11.1, 12.7, 14.2, and 16.4 km h<sup>-1</sup> [5.1, 6.0, 6.9, 7.9, 8.8, and 10.2 mph] and vacuum pressures were varied depending on the speed levels between 2.24 to 3.11 kPa [9.0 to 12.5 in. of water]. During the lab test, each test was continued up to counting 500 seeds by the seed sensors and also repeated 5 times.

### 3.3.3. Calibration Test with Seed Tube

In order to determine the optimized vacuum pressure for every speed levels, each planting speed were tested in different vacuum pressures. Based on the recommendation of Randy Klassen, (RDK Enterprises, personal communication, 2016), for each speed level we used 2.86 kPa [11.5 in. of water] vacuum pressure as the starting point, then decreased the vacuum pressure by 0.124 kPa [0.5 in. of water] until a reduction trend in singulation rate were seen; in some speed levels, where needed, this whole process was repeated by instead increasing the vacuum pressure. Table 4 shows different planting speeds and the vacuum pressures that they have been tested with as calibration test treatments.

**Table 4. Calibration test treatments for seed tube.**

Planting Speed (km h <sup>-1</sup> ) [mph]	Vacuum Pressure (kPa) [in. of water]							
8.2 [5.1]	2.24 [9.0]	2.36 [9.5]	2.49 [10.0]	2.61 [10.5]	2.74 [11.0]	2.86 [11.5]	2.99 [12.0]	-
9.7 [6.0]	2.24 [9.0]	2.36 [9.5]	2.49 [10.0]	2.61 [10.5]	2.74 [11.0]	2.86 [11.5]	-	-
11.1 [6.9]	2.24 [9.0]	2.36 [9.5]	2.49 [10.0]	2.61 [10.5]	2.74 [11.0]	2.86 [11.5]	-	-
12.7 [7.9]	2.24 [9.0]	2.36 [9.5]	2.49 [10.0]	2.61 [10.5]	2.74 [11.0]	2.86 [11.5]	2.99 [12.0]	3.11 [12.5]
14.2 [8.8]	-	2.36 [9.5]	2.49 [10.0]	2.61 [10.5]	2.74 [11.0]	2.86 [11.5]	2.99 [12.0]	-
16.4 [10.2]	-	2.36 [9.5]	2.49 [10.0]	2.61 [10.5]	2.74 [11.0]	2.86 [11.5]	2.99 [12.0]	3.11 [12.5]

Each speed level was tested with shown vacuum pressures.

For calibration tests, a seed tube was tested on the test stand as a reference seed delivery device. On these tests, all level of speeds was tested with different vacuum pressures to determine the required vacuum pressure for each speed level and define the optimized treatments. Due to having 5 replications for each test treatment, optimized treatments were determined by considering



the vacuum pressure with the highest mean of singulation rates on each speed level. In this regard, since planting speed was the only independent variable for the main tests on the new seed delivery system, there were 6 different treatments based on the speed levels (Table 5). In the other word, for each speed level, there was only one optimized vacuum level.

**Table 5. Optimized treatments for seed tube.**

Treatment	1	2	3	4	5	6
Planting Speed (km h <sup>-1</sup> ) [mph]	8.2 [5.1]	9.7 [6.0]	11.1 [6.9]	12.7 [7.9]	14.2 [8.8]	16.4 [10.2]

Each speed level had only one vacuum level, so the speed levels can be considered as treatments.

### 3.3.4. Testing the New Seed Delivery System

By defining the optimized treatments based on the calibration tests with the seed tube, the results of optimized treatments for the seed tube were extracted from the rest of calibration tests as control values to compare them with the results of the new seed delivery system. In this regard, the results of optimized treatments for the seed tube were evaluated by conducting a one-way ANOVA test with SAS software for each dependent variable with respect to changes in planting speed. These dependent variables were defined as seed population (seeding rate), singulation, skips, multiples rates, and SRI (coefficient of variation in seed spacing).

Unlike the seed tube, the new seed delivery system was not able to complete the tests for higher speeds 12.7, 14.2, and 16.4 km h<sup>-1</sup> [7.9, 8.8, and 10.2 mph], due to facing overload situations on the stepper motor that consequently stopped the test process. However, the prototype for the new seed delivery system was able to complete the tests for three lower speed levels 8.2, 9.7, and 11.1 km h<sup>-1</sup> [5.1, 6.0, and 6.9 mph]. On the other hand, to run the new seed delivery system for each planting speed level there were two values for the stepper motor speed. Table 6 shows the treatments for testing the new seed delivery system with 3 planting speed levels and 2 stepper motor speeds for each planting speed level.

**Table 6. Test treatments for the new seed delivery system.**

Treatment	1	2	3	4	5	6
Planting Speed (km h <sup>-1</sup> ) [mph]	8.2 [5.1]	8.2 [5.1]	9.7 [6.0]	9.7 [6.0]	11.1 [6.9]	11.1 [6.9]
Stepper Motor Speed (steps sec. <sup>-1</sup> )	1,904	1,905	2,240	2,241	2,577	2,578

Each planting speed level has two values for the stepper motor speed.

To analyze the test results for the new seed delivery, a one-way ANOVA test with SAS software was conducted for each dependent variable with respect to changes in planting speed. In addition, besides evaluating the test results for both the seed tube (considered as control) and the new seed delivery system individually, they also have been evaluated together in a two-way ANOVA test in order to compare the new seed delivery system with the seed tube. For all one-way and two-way ANOVA tests, GLM procedure and t-Test (LSD) were used to test the results.

## 4. RESULTS

During the lab tests, dependent variables like actual seed population (seeding rate), singulation, skips, multiples rates, and SRI values were monitored for both seed tube and the new seed delivery system. The results from these two devices were evaluated separately and together.

### 4.1. Seed Tube Calibration Results

During the calibration tests on seed tube, each planting speed was tested with different vacuum pressures. All these calibration tests were repeated for 5 times and for each calibration test treatment, average value of the seed singulation rates were calculated. Table 7 shows the average seed singulation rates for calibration test treatments and the highest means of singulation rates among different vacuum pressures for each planting speed.

**Table 7. Average seed singulation rates on calibration tests.**

Planting Speed (km h <sup>-1</sup> ) [mph]	Vacuum Pressure (kPa) [in. of water]							
	2.24 [9.0]	2.36 [9.5]	2.49 [10.0]	2.61 [10.5]	2.74 [11.0]	2.86 [11.5]	2.99 [12.0]	3.11 [12.5]
	Average Seed Singulation Rate (%)							
8.2 [5.1]	97.24	97.72	98.32*	97.84	98.20	97.84	97.12	-
9.7 [6.0]	98.20	97.64	98.32*	98.16	97.88	97.76	-	-
11.1 [6.9]	97.76	98.04	97.84	97.60	98.72*	97.68	-	-
12.7 [7.9]	97.64	97.48	97.80	97.72	97.76	98.24*	98.16	98.00
14.2 [8.8]	-	97.52	97.60	97.72	97.76	98.04*	97.52	-
16.4 [10.2]	-	97.64	97.96	98.12*	97.68	97.32	97.32	96.88

Each seed singulation value in this table is the average value of 5 replications for tested treatments. The highlighted values are the highest means of singulation rates among different vacuum pressure in each planting speed level.

Based on the above calibration test results and its highlighted values, the optimized vacuum pressures for different speed levels in optimized treatments for seed tube were identified as it shows in the Table 8.

**Table 8. Optimized treatments for seed tube with their vacuum pressures.**

Treatment	1	2	3	4	5	6
Planting Speed (km h <sup>-1</sup> ) [mph]	8.2 [5.1]	9.7 [6.0]	11.1 [6.9]	12.7 [7.9]	14.2 [8.8]	16.4 [10.2]
Vacuum Pressure (kPa) [in. of water]	2.49 [10.0]	2.49 [10.0]	2.74 [11.0]	2.86 [11.5]	2.86 [11.5]	2.61 [10.5]

Each pair of planting speed and vacuum pressure would be considered as a treatment.

#### 4.2. Seed Tube Evaluation

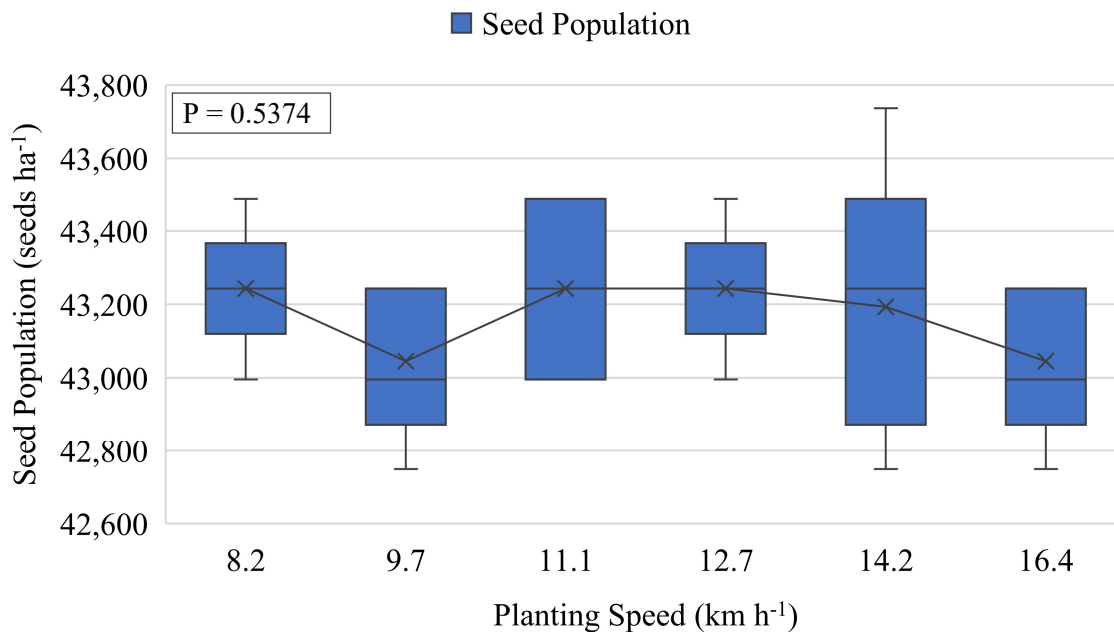
In order to evaluate the performance of the seed tube during the lab test, the monitored dependent variables for optimized treatments (Table 8), which included 6 treatments with 5 replications, were extracted from the calibration test results. Table 9 shows the average result values of 5 replications for the dependent variables of optimized seed tube treatments tests.

**Table 9. Averages values for dependent variables of the optimized seed tube tests.**

Trt.	Planting Speed (km h <sup>-1</sup> ) [mph]	Seed Population (seeds ha <sup>-1</sup> ) [seeds acre <sup>-1</sup> ]	Singulation (%)	Skips (%)	Multiples (%)	SRI (Middle) (%)	SRI (Bottom) (%)
1	8.2 [5.1]	43,243 [17,500]	98.3	0.8	0.8	8.3	10.4
2	9.7 [6.0]	43,046 [17,420]	98.3	1.1	0.6	8.5	10.3
3	11.1 [6.9]	43,243 [17,500]	98.7	0.6	0.7	10.1	11.8
4	12.7 [7.9]	43,243 [17,500]	98.2	0.8	1.0	8.9	11.8
5	14.2 [8.8]	43,194 [17,480]	98.0	1.0	0.9	11.4	14.5
6	16.4 [10.2]	43,046 [17,420]	98.1	1.2	0.7	12.4	15.7

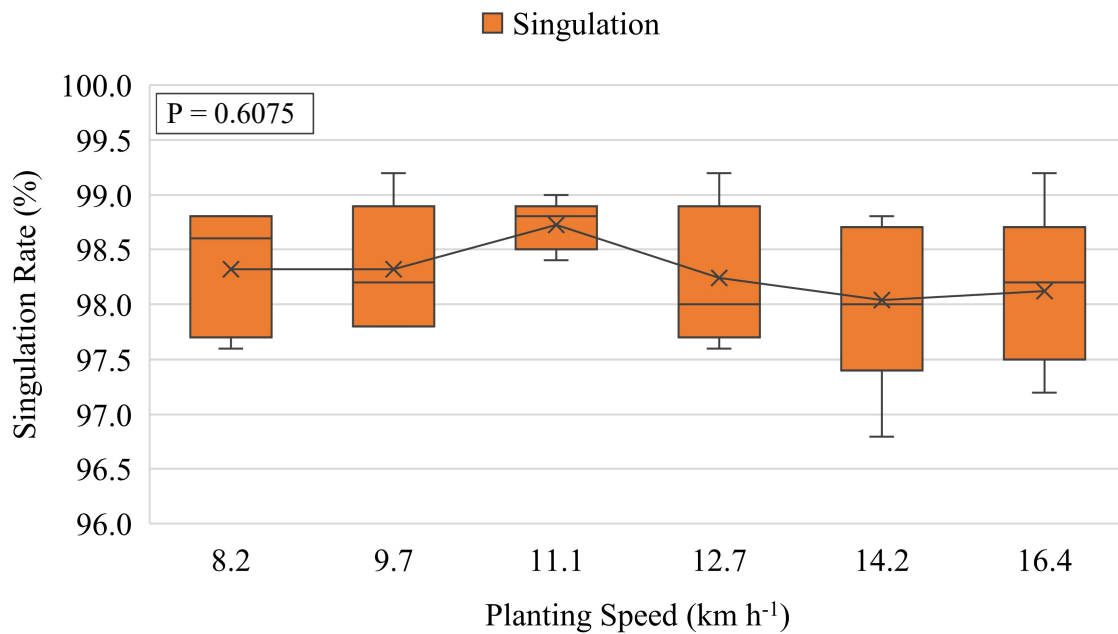
This table shows average values of 5 replications for 6 treatments (Trt.). Dependent variables were seed population, singulation, skips, multiples rates, and SRI for both middle and bottom sensors.

The results from the seed tube test show that there is no statistically significant difference for dependent variables seed population, singulation, skips, and multiples rates regarding changes in planting speed (Figures 21, 22, and 23). It means that, these variables did not show any dependency on planting speed. However, the results for SRI values from both seed sensors reflect statistically significant differences regarding increasing planting speed (Figure 24).



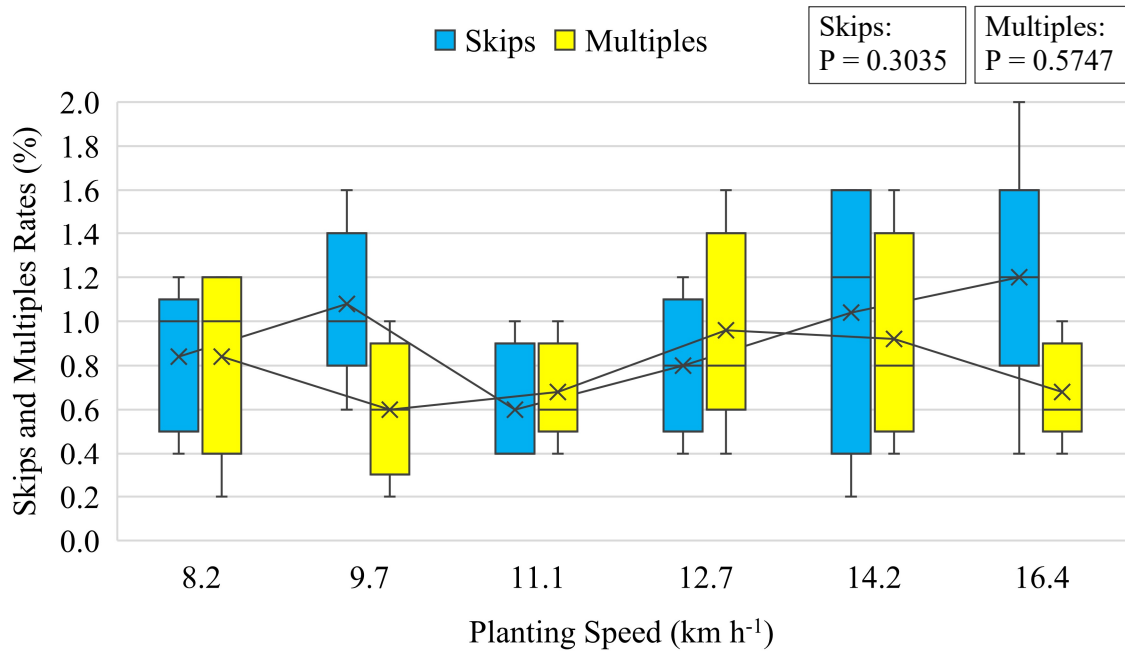
**Figure 21. Seed population on seed tube evaluation. Each box presents the distribution of seed population values in 5 replications for each planting speed level.**

According to Table 9 and Figure 21, the highest average value of seed population is equal to the target seed population that is 43,243 seeds ha<sup>-1</sup> [17,500 seeds acre<sup>-1</sup>], which occurred at 8.2, 11.1, and 12.7 km h<sup>-1</sup> [5.1, 6.9, and 7.9 mph], respectively. P-value for seed population values is 0.5374 that is higher than  $\alpha$  equal to 0.05, so the differences in seed population values on seed tube are not statistically significant.



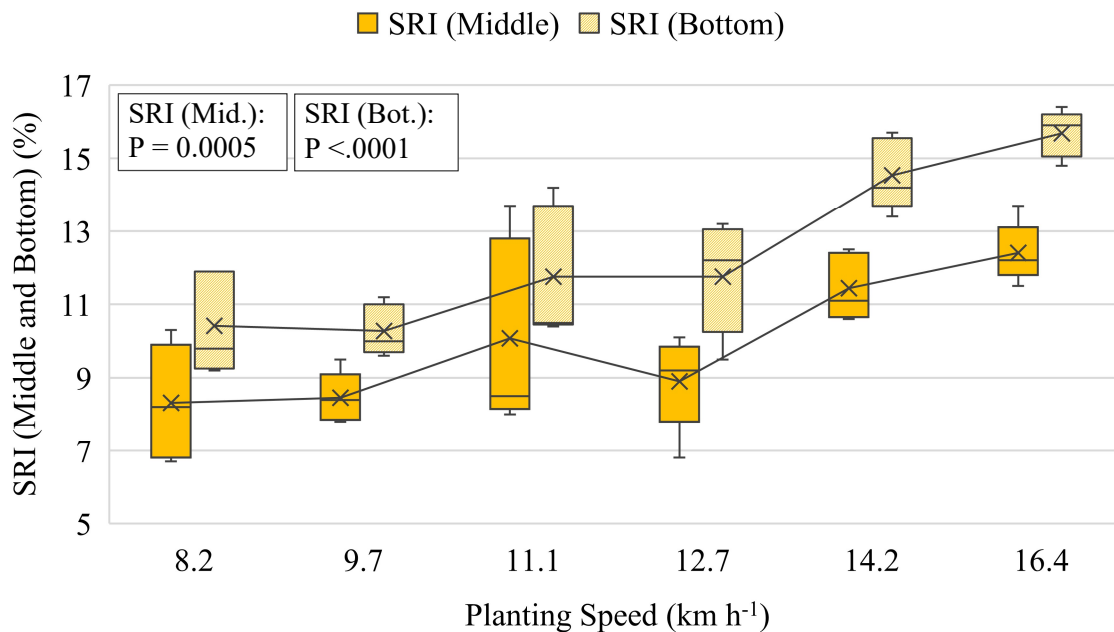
**Figure 22. Singulation rate on seed tube evaluation. Each box presents the distribution of singulation rate values in 5 replications for each planting speed level.**

According to Table 9 and Figure 22, the highest average value of singulation rate is 98.7% and the lowest is 98.0%, which occurred at 11.1 and 14.2 km h<sup>-1</sup> [6.9 and 8.8 mph], respectively. P-value for singulation rate values is 0.6075 that is higher than  $\alpha$  equal to 0.05, so the differences in singulation rate values on seed tube are not statistically significant.



**Figure 23. Skips and multiples rates on seed tube evaluation. Each box presents the distribution of skips or multiples rates values in 5 replications for each planting speed level.**

According to Table 9 and Figure 23, The lowest average value of skips rate is 0.6% and the highest is 1.2%, which occurred at 11.1 and 16.4 km h<sup>-1</sup> [6.9 and 10.2 mph], respectively. And the lowest average value of multiples rate is 0.6% and the highest is 1.0%, which occurred at 9.7 and 12.7 km h<sup>-1</sup> [6.0 and 7.9 mph], respectively. P-values for skips and multiples rates values are 0.3035 and 0.5747, respectively; which both are higher than  $\alpha$  equal to 0.05, so the differences in skips and multiples rates values on seed tube are not statistically significant. In addition, at planting speed of 11.1 km h<sup>-1</sup> [6.9 mph] both skips and multiples rates are standing close to each other on low amounts 0.6 and 0.7%, respectively. By raising the planting speed, the variation on skips and multiples rates tends to increase.



**Figure 24. SRI (middle and bottom sensors) on seed tube evaluation. Each box presents the distribution of SRI (middle or bottom sensor) values in 5 replications for each planting speed level.**

According to Table 9 and Figure 24, the lowest average value of SRI for middle sensor is 8.3% at 8.2 km h<sup>-1</sup> [5.1 mph] and it increases gradually to 12.4% at 16.4 km h<sup>-1</sup> [10.2 mph] for the highest average value. And the lowest average value of SRI for bottom sensor is 10.3% at 9.7 km h<sup>-1</sup> [6.0 mph] and it increases gradually to 15.7% at 16.4 km h<sup>-1</sup> [10.2 mph] for the highest average value. P-values for SRI (middle) and SRI (bottom) values are 0.0005 and <0.0001, respectively; which both are lower than  $\alpha$  equal to 0.05, so the differences in SRI (middle and bottom) values on seed tube are statistically significant, which means that increasing the planting speed would reduce the consistency of seed spacing.

By comparing the values in Table 9 and Figures 21 to 24, it is more likely to get the desired values for dependent variables in lower planting speeds than in higher planting speeds. However, due to wide range of data distribution at every speed level, which shows how seeds behaved



randomly during these tests, a meaningful trend regarding speed change cannot be found among some of these dependent variables, like seed population, singulation rate, skips and multiples.

### 4.3. New Seed Delivery System Evaluation

To evaluate the new seed delivery system, it has been tested with 3 different planting speed level and 2 stepper motor speed for each planting speed level, as it has been shown in Table 6. Also, by considering the optimized vacuum pressure from Table 8, the actual treatments for testing the new seed delivery system were shown in Table 10. The results for testing the new seed delivery system are showed in Table 11, which are the average values of 5 replications for the dependent variables of the new seed delivery system treatments tests.

**Table 10. Test treatments for the new seed delivery system with their vacuum pressures.**

Treatment	1	2	3	4	5	6
Planting Speed (km h <sup>-1</sup> ) [mph]	8.2 [5.1]	8.2 [5.1]	9.7 [6.0]	9.7 [6.0]	11.1 [6.9]	11.1 [6.9]
Vacuum Pressure (kPa) [in. of water]	2.49 [10.0]	2.49 [10.0]	2.49 [10.0]	2.49 [10.0]	2.74 [11.0]	2.74 [11.0]
Stepper Motor Speed (steps sec. <sup>-1</sup> )	1,904	1,905	2,240	2,241	2,577	2,578

Each planting speed has one value for vacuum pressure and two values for the stepper motor speed.

**Table 11. Averages values for dependent variables of the new seed delivery system treatments tests.**

Trt.	Planting Speed (km h <sup>-1</sup> ) [mph]	Seed Population (seeds ha <sup>-1</sup> ) [seeds acre <sup>-1</sup> ]	Singulation (%)	Skips (%)	Multiples (%)	SRI (Top) (%)	SRI (Bottom) (%)
1	8.2 [5.1]	46,703 [18,900]	92.4	0.1	7.5	18.6	24.8
2	8.2 [5.1]	47,246 [19,120]	91.4	0.0	8.6	19.6	25.3
3	9.7 [6.0]	47,000 [19,020]	91.6	0.2	8.2	20.5	25.9
4	9.7 [6.0]	47,296 [19,140]	91.2	0.2	8.6	21.6	26.4
5	11.1 [6.9]	48,037 [19,440]	89.8	0.1	10.1	21.5	27.1
6	11.1 [6.9]	47,246 [19,120]	91.0	0.1	8.9	19.9	26.1

This table shows average values of 5 replications for 6 treatments (Trt.). Dependent variables were seed population, singulation, skips, multiples rates, and SRI for both top and bottom sensors.

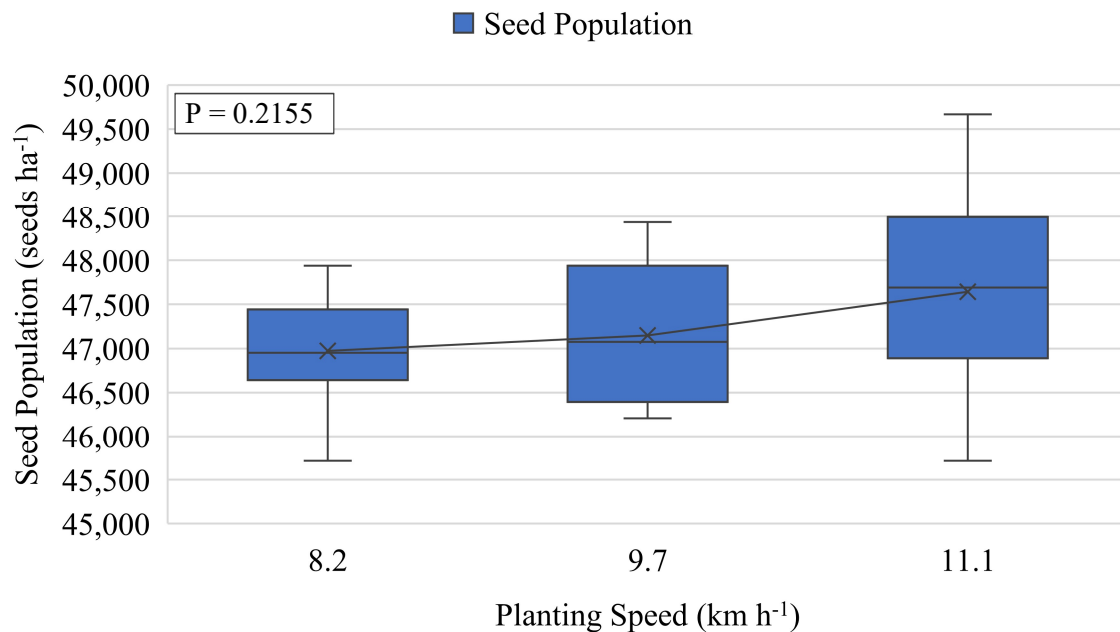
Since planting speed was considered as the main independent variable during all tests, in order to evaluate the new seed delivery system the results from Table 11 got merged together based on the planting speed levels by averaging the values from the same planting speed level (Table 12).

**Table 12. Averages values for dependent variables of the new seed delivery system for each planting speed.**

Planting Speed (km h <sup>-1</sup> ) [mph]	Seed Population (seeds ha <sup>-1</sup> ) [seeds acre <sup>-1</sup> ]	Singulation (%)	Skips (%)	Multiples (%)	SRI (Top) (%)	SRI (Bottom) (%)
8.2 [5.1]	46,975 [19,010]	91.9	0.1	8.0	19.1	25.0
9.7 [6.0]	47,148 [19,080]	91.4	0.2	8.4	21.1	26.1
11.1 [6.9]	47,642 [19,280]	90.4	0.1	9.5	20.7	26.6

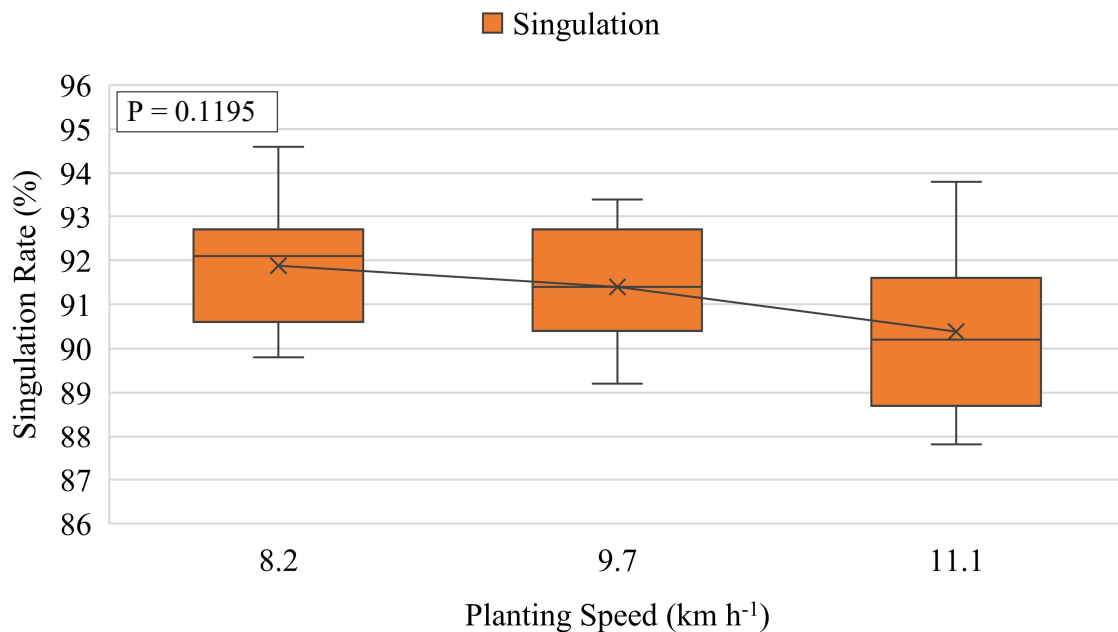
This table shows the average values of merged treatments in Table 11 based on planting speed levels (each has 10 replications in total). Dependent variables were seed population, singulation, skips, multiples rates, and SRI for both top and bottom sensors.

The results from the new seed delivery system show that there is no statistically significant difference for dependent variables seed population, singulation, skips, and multiples rates regarding changes in planting speed (Figures 25, 26, and 27). It means that, these variables did not show any dependency on planting speed. However, the results for SRI values from both seed sensors reflect that for the top sensor there is no statistically significant difference among SRI values regarding increasing planting speed, while for the bottom sensor there are statistically significant differences among SRI values regarding increasing planting speed (Figure 28).



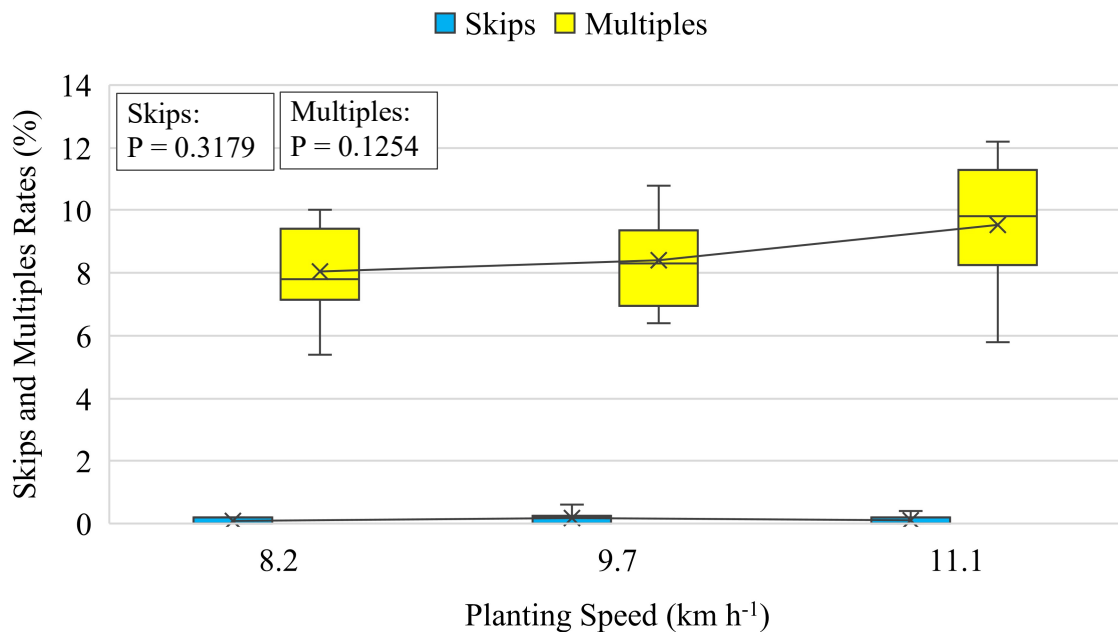
**Figure 25. Seed population on the new seed delivery system evaluation. Each box presents the distribution of seed population values in 10 replications (5 replications for 2 merged treatments) for each planting speed level.**

According to Table 12 and Figure 25, seed population average values increased by 1.42% from 46,975 to 47,642 seeds ha<sup>-1</sup> [19,010 to 19,280 seeds acre<sup>-1</sup>], which occurred at 8.2 to 11.1 km h<sup>-1</sup> [5.1 to 6.9 mph]. P-value for seed population values is 0.2155 that is higher than  $\alpha$  equal to 0.05, so the differences in seed population values on the new seed delivery system are not statistically significant. It should be mentioned that the seed population average values are 8.63 to 10.17% higher than the target seed population that is 43,243 seeds ha<sup>-1</sup> [17,500 seeds acre<sup>-1</sup>], which means that the multiples rate were relatively high during these tests.



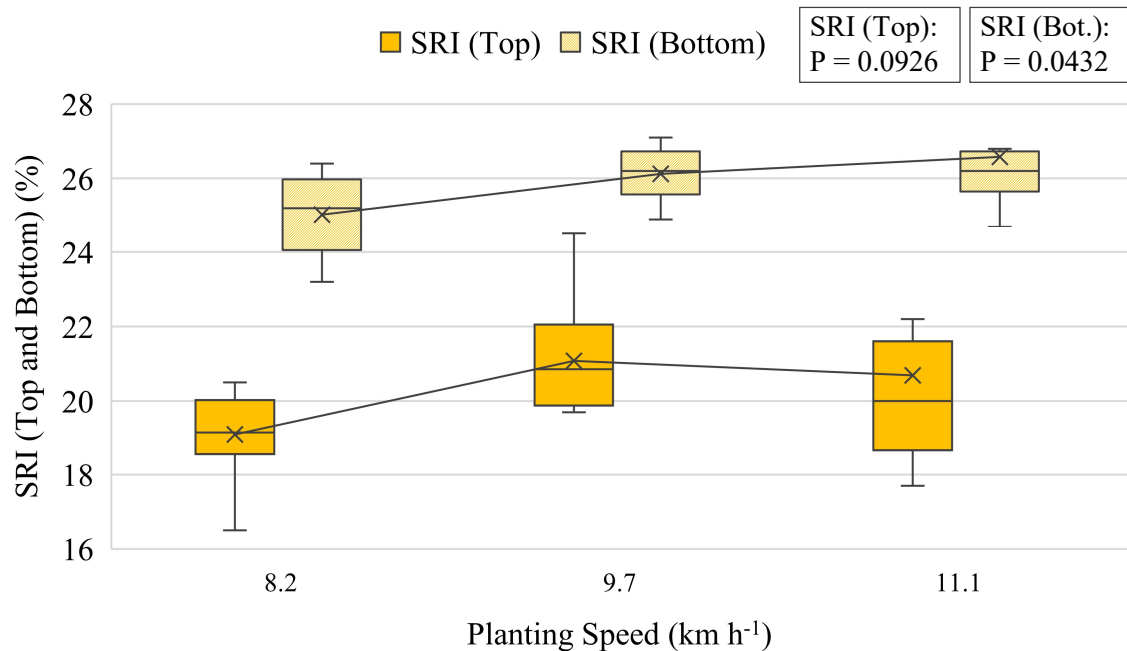
**Figure 26. Singulation rate on the new seed delivery system evaluation. Each box presents the distribution of singulation rate values in 10 replications (5 replications for 2 merged treatments) for each planting speed level.**

According to Table 12 and Figure 26, singulation rate average values decreased from 91.9 to 90.4%, which occurred at 8.2 to 11.1 km h<sup>-1</sup> [5.1 to 6.9 mph]. P-value for singulation rate values is 0.1195 that is higher than  $\alpha$  equal to 0.05, so the differences in singulation rate values on the new seed delivery system are not statistically significant.



**Figure 27. Skips and multiples rates on the new seed delivery system evaluation. Each box presents the distribution of skips or multiples rates values in 10 replications (5 replications for 2 merged treatments) for each planting speed level.**

According to Table 12 and Figure 27, skips rate average values remained almost the same at relatively low amounts around 0.1 to 0.2%, while multiples rate average values increased from 8.0 to 9.5%, which occurred at 8.2 to 11.1 km h<sup>-1</sup> [5.1 to 6.9 mph]. P-values for skips and multiples rates values are 0.3179 and 0.1254, respectively; which both are higher than  $\alpha$  equal to 0.05, so the differences in skips and multiples rates values on the new seed delivery system are not statistically significant. By comparing Figure 25 and 27, it can be recognized that the percentage of extra seed population over target value (8.63 to 10.17%) is relatively close to multiples rate average values (8.0 to 9.5%).



**Figure 28. SRI (top and bottom sensors) on the new seed delivery system evaluation. Each box presents the distribution of SRI (top or bottom sensor) values in 10 replications (5 replications for 2 merged treatments) for each planting speed level.**

According to Table 12 and Figure 28, SRI average values for top sensor had slight changes between 19.1 to 21.1%, while SRI average values for bottom sensor increased slightly from 25.0 to 26.6%, which occurred at 8.2 to 11.1 km h<sup>-1</sup> [5.1 to 6.9 mph]. P-value for SRI (top) values is 0.0926 that is higher than  $\alpha$  equal to 0.05, so the differences in SRI (top) values on the new seed delivery system are not statistically significant, which means that changes in planting speed does not significantly affect the consistency of seed spacing based on top sensor readings. However, P-value for SRI (bottom) values is 0.0432 that is lower than  $\alpha$  equal to 0.05, so the differences in SRI (bottom) values on the new seed delivery system are statistically significant, which means that increasing the planting speed would reduce the consistency of seed spacing.

#### 4.4. New Seed Delivery System vs. Seed Tube

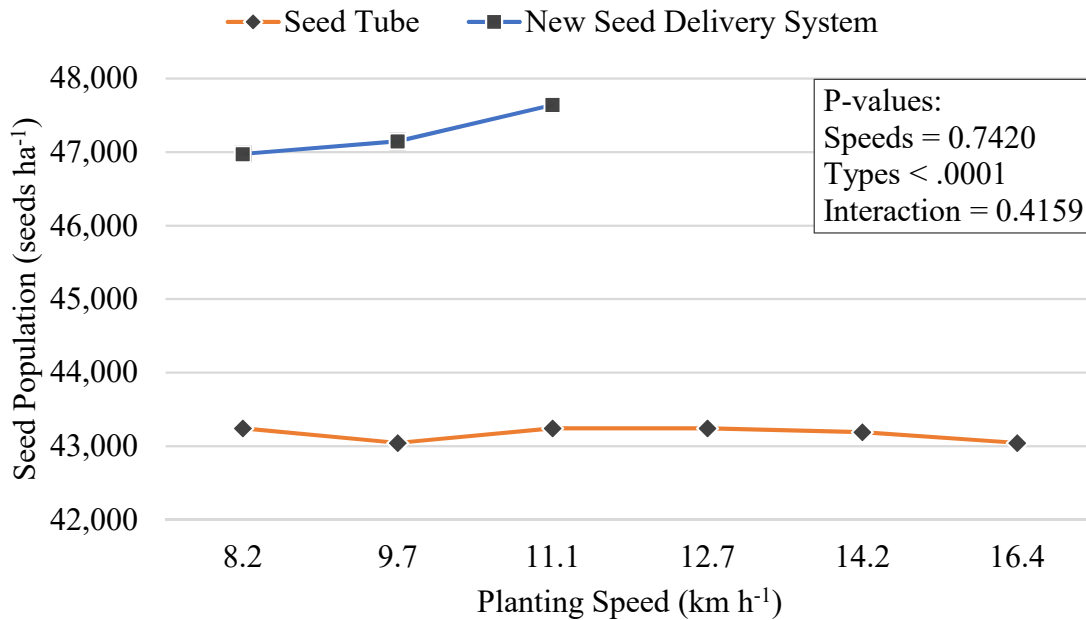
The comparison between the new seed delivery system and seed tube were conducted to determine possible interactions of dependent variables over these two types of seed delivery by

using a two-way ANOVA test. The results show that for both seed tube and the new seed delivery system, dependent variables like population, singulation, skips, and multiples were not affected by the speed (P-values are higher than  $\alpha$  equal to 0.05). However, SRI values were more likely to increase with speed (P-values are lower than  $\alpha$  equal to 0.05), which means that planting with higher speeds would have a negative effect on uniformity of seed spacing. In addition, there is a statically significant difference between the two seed delivery methods for all variables (P-values  $< 0.0001$  are lower than  $\alpha$  equal to 0.05), while there is no interaction between these two seed delivery methods and six planting speeds for none of the dependent variables (P-values are higher than  $\alpha$  equal to 0.05). Tables 13 to 16 show the average values of dependent variables for seed tube and the new seed delivery system (from Tables 9 and 12) and Figures 29 to 32 illustrate these average values in graphs with their P-values form two-way ANOVA tests.

**Table 13. Seed population average values on seed tube and the new seed delivery system.**

Planting Speed (km h <sup>-1</sup> ) [mph]	Seed Tube	New Seed Delivery System
	Seed Population (seeds ha <sup>-1</sup> ) [seeds acre <sup>-1</sup> ]	
8.2 [5.1]	43243 [17500]	46975 [19010]
9.7 [6.0]	43046 [17420]	47148 [19080]
11.1 [6.9]	43243 [17500]	47642 [19280]
12.7 [7.9]	43243 [17500]	-
14.2 [8.8]	43194 [17480]	-
16.4 [10.2]	43046 [17420]	-

This table shows the average values of seed population in each planting speed level for seed tube (from Table 9) and the new seed delivery system (from Table 12).



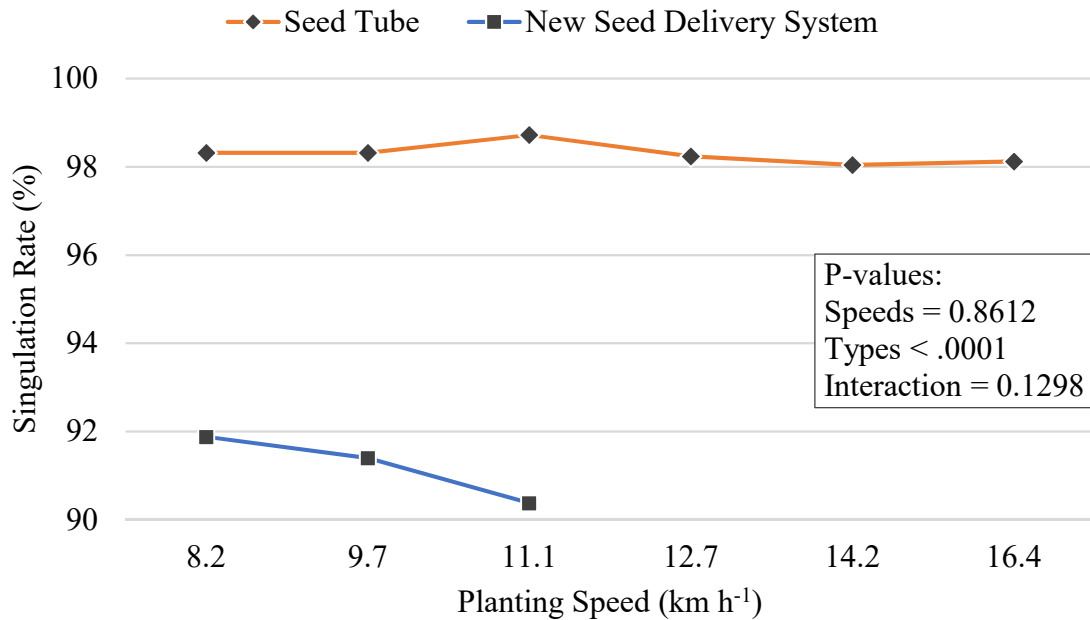
**Figure 29. Seed population average values on seed tube and the new seed delivery system. Each marker presents the seed population average values for each planting speed level.**



**Table 14. Singulation rate average values on seed tube and the new seed delivery system.**

Planting Speed (km h <sup>-1</sup> ) [mph]	Seed Tube	New Seed Delivery System
	Singulation (%)	
8.2 [5.1]	98.3	91.9
9.7 [6.0]	98.3	91.4
11.1 [6.9]	98.7	90.4
12.7 [7.9]	98.2	-
14.2 [8.8]	98.0	-
16.4 [10.2]	98.1	-

This table shows the average values of singulation rate in each planting speed level for seed tube (from Table 9) and the new seed delivery system (from Table 12).

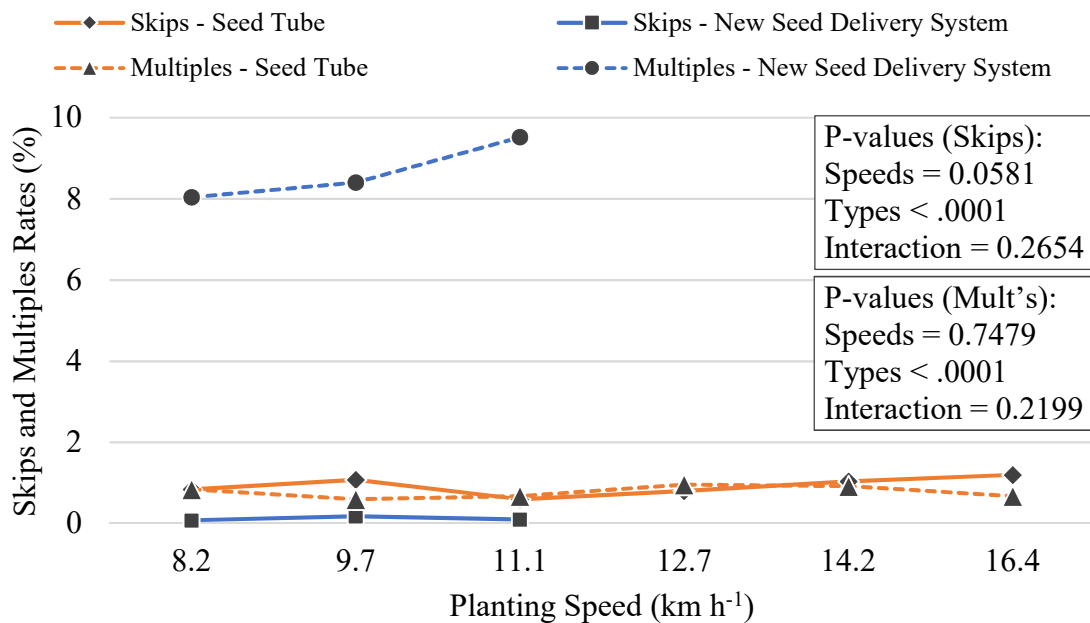


**Figure 30. Singulation rate average values on seed tube and the new seed delivery system. Each marker presents the singulation rate average values for each planting speed level.**

**Table 15. Skips and multiples rates average values on seed tube and the new seed delivery system.**

Planting Speed (km h <sup>-1</sup> ) [mph]	Seed Tube		New Seed Delivery System	
	Skips (%)	Multiples (%)	Skips (%)	Multiples (%)
8.2 [5.1]	0.8	0.8	0.1	8.0
9.7 [6.0]	1.1	0.6	0.2	8.4
11.1 [6.9]	0.6	0.7	0.1	9.5
12.7 [7.9]	0.8	1.0	-	-
14.2 [8.8]	1.0	0.9	-	-
16.4 [10.2]	1.2	0.7	-	-

This table shows the average values of skips and multiples rates in each planting speed level for seed tube (from Table 9) and the new seed delivery system (from Table 12).

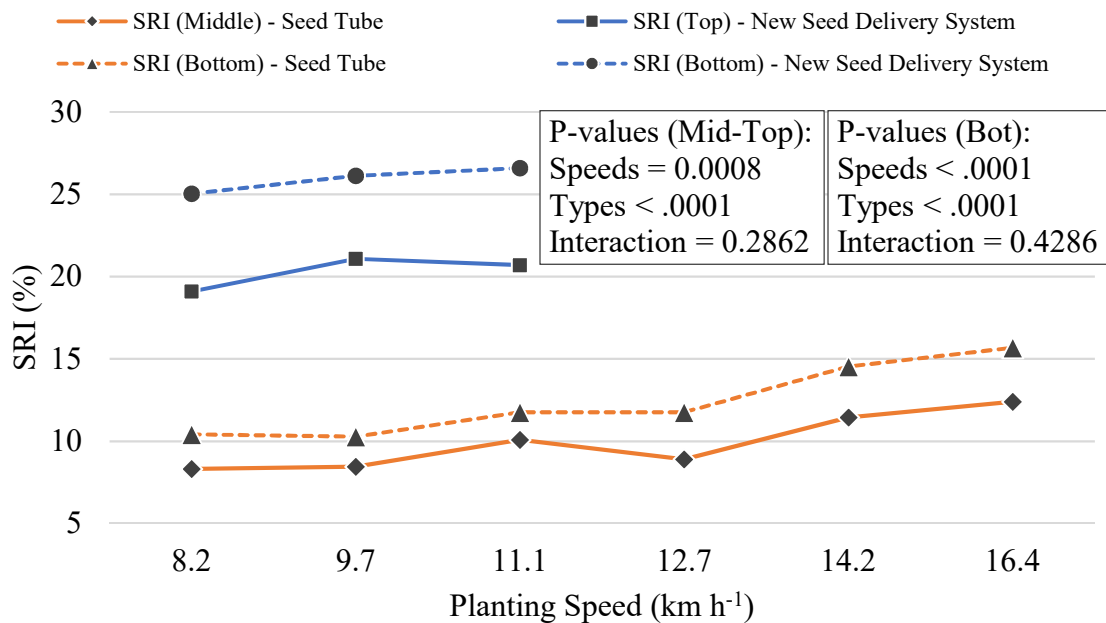


**Figure 31. Skips and multiples rates average values on seed tube and the new seed delivery system. Each marker presents the skips or multiples rates average values for each planting speed level.**

**Table 16. SRI (upper and lower sensors) average values on seed tube and the new seed delivery system.**

Planting Speed (km h <sup>-1</sup> ) [mph]	Seed Tube		New Seed Delivery System	
	SRI (Middle) (%)	SRI (Bottom) (%)	SRI (Top) (%)	SRI (Bottom) (%)
8.2 [5.1]	8.3	10.4	19.1	25.0
9.7 [6.0]	8.5	10.3	21.1	26.1
11.1 [6.9]	10.1	11.8	20.7	26.6
12.7 [7.9]	8.9	11.8	-	-
14.2 [8.8]	11.4	14.5	-	-
16.4 [10.2]	12.4	15.7	-	-

This table shows the average values of SRI (upper and lower sensors) in each planting speed level for seed tube (from Table 9) and the new seed delivery system (from Table 12).



**Figure 32. SRI (upper and lower sensors) average values on seed tube and the new seed delivery system. Each marker presents the SRI (upper or lower) average values for each planting speed level.**

## 5. DISCUSSION

The outcomes of testing these two seed delivery devices are indicating some of the issues and challenges regarding seed delivery devices and extra-large confection sunflower seeds. As it was mentioned, in this study both seed delivery devices were tested in a stationary condition in the lab, while the field condition is so much different and the negative effect of seed tube on uniformity of seed spacing would be more obvious in a field test. This might be one of the reasons that seed tube had better test results compare to the new seed delivery system in this study. The other major problem with this project was having broken seeds while testing the new seed delivery system, which increased multiples and consequently affected seed population, singulation, skips and SRI values.

The reasons behind belts causing damages on the sunflower seeds might be using two belts configuration and/or utilizing guiding nubs for adjusting the orientation of seeds between the belts. In a two-belt configuration, both belts should run with equal linear velocity on belts surface. Otherwise, the speed difference might cause cracks on the seed hull, even for small amounts. In practice, it is not easy to run both belts with exactly equal speeds, as it happened in this project. During the tests, the linear velocity on the belts surfaces were measured with tachometer, which indicated an inconstant small difference between them. In addition, to adjust the orientation of seeds, two guiding nubs were installed in the seed path between the belts, which might cause some damage on the seeds in high speeds. However, using these two nubs were necessary to avoid getting seeds stocked at the entrance of the bottom tube.

The main limitation of this study was to determine the exact source of issues during the test process. Unfortunately, the only symptom that indicated existing an issue was overloading the stepper motor, which would stop the system immediately. For this reason, the only possible way

to diagnose the issues was to consider every probable cause and apply the suitable solution for that.

The test results of the new seed delivery system are indicating a systematic problem that can be related to the damaged seeds. In order to improve the performance of the new seed delivery system, this systematic problem should be removed by redesigning this system to avoid breaking the seeds.

## 6. CONCLUSION

In this project a powered seed delivery system was developed with the concept of two-belt mechanism configuration to convey the seeds. The prototype of the new seed delivery system and seed tube were tested by “MeterMax<sup>®</sup> Ultra Test Stand” with extra-large sunflower seeds to compare and evaluate the fabricated prototype. The lab tests results show that dependent variables like seed population, singulation, skips, and multiples rates are not affected by the planting speed (P-values > 0.05), while it is more likely to reduce the consistency of seed spacing by increasing the planting speed (P-values < 0.05). However, under field condition the tests results should be concluded in a different way, especially for the seed tube. In these lab tests, the new seed delivery system was not able to perform as expected compared to the seed tube due to breaking the seeds into pieces, and consequently causing a systematic error in the test results. In order to avoid this systematic error, the new seed delivery system needs to be re-designed from a two-belt mechanism configuration into single-belt form.

## **7. RECOMMENDATIONS FOR FUTURE STUDIES**

Both seed metering and delivery systems are affecting the performance of precision planters. In this regard, to improve the performance of precision planters, it is important to conduct more researches related to the engineering aspect of seed delivery systems, or in a better form, studying on both seed meter and delivery systems together.

By considering the outcomes and challenges of this study, instead of using a two-belt configuration, it is recommended to utilize single-belt configuration for delivering seeds to avoid damaging them. Besides that, it would be more realistic and practical to conduct field tests, which would add the field condition to the affecting factors.

## REFERENCES

- Anaheim Automation. (n.d.). PKG-343-DPN-CBL system diagram and specifications. Anaheim, CA. Retrieved April 26, 2017, from <https://www.anaheimautomation.com/manuals/discounted%20packages/L010883%20-%20PKG-343-DPN-CBL%20Spec%20Sheet.pdf>
- BRECOflex Co., L. (2003). Timing belt backings. Eatontown, NJ. Retrieved April 26, 2017, from <http://www.brecoflex.com/wp-content/uploads/2016/07/B208.pdf>
- Breece, H. E., Hansen, H. V., & Hoerner, T. A. (1975). *Fundamentals of machine operation: planting*. (R. F. Espenschied, & K. R. Carlson, Eds.) Moline, IL: Deere & Company.
- Garner, E., Friestad, M. E., Mariman, N. A., Rylander, D. J., & Thiemke, D. B. (2013). *USA Patent No. US8468960 B2*. Retrieved from <https://www.google.com/patents/US8468960>
- Garner, E., Friestad, M. E., Mariman, N. A., Rylander, D. J., & Thiemke, D. B. (2014). *USA Patent No. US8789482 B2*. Retrieved from <http://www.google.ch/patents/US8789482>
- Kachman, S. D., & Smith, J. A. (1995). Alternative measures of accuracy in plant spacing for planters using single seed metering. *Transactions of the ASAE*, 38(2), 379-387. doi:10.13031/2013.27843
- Kandel, H. (2013, January). 2012 NSA crop survey report. *The Sunflower*, 39(1), pp. 10-12. Retrieved from [https://issuu.com/forumprinting/docs/nsa\\_jan\\_2013?mode=window&backgroundColor=%23ffffff](https://issuu.com/forumprinting/docs/nsa_jan_2013?mode=window&backgroundColor=%23ffffff)
- Kandel, H. (2014, January). 2013 NSA crop survey report. *The Sunflower*, 40(1), pp. 20-22. Retrieved from <http://sunflower.epubs.forumprinting.com/publication/?i=190098>
- Kandel, H., & Gulya, T. (2016, January). 2015 National sunflower crop survey. *The Sunflower*, 42(1), pp. 14-17. Retrieved from <http://sunflower.epubs.forumprinting.com/publication/?i=286040>
- Kepner, R. A., Bainer, R., & Barger, E. L. (1978). *Principles of farm machinery* (3 ed.). Westport, CT: Avi Publication Company, Inc.
- Li, Y., Bingxin, Y., Yiming, Y., Xiantao, H., Quanwei, L., Zhijie, L., . . . Dongxing, Z. (2016). Global overview of research progress and development of precision maize planters. *International Journal of Agricultural and Biological Engineering*, 9(1), 9-26. doi:10.3965/j.ijabe.20160901.2285
- Lilleboe, D. (2008, January). Sunflower seed placement & stand uniformity. National Sunflower Association. Retrieved from <https://www.sunflowernsa.com/uploads/3/planting-sunflower.pdf>



- Manufacturing, G. P. (n.d.). Air-Pro® meters. Retrieved April 26, 2017, from <http://www.greatplainsag.com/en/9286/great-plains-planters-comply-best-practices-pollinator-protection>
- Manufacturing, K. (n.d.). 4000 Series vacuum meter. Retrieved from <http://www.kinze.com/feature.aspx?id=11c07537-cef9-47da-a801-ef46117da952&name=vacuum+meter>
- Manufacturing, K. (n.d.). Brush-type seed meters. Retrieved April 26, 2017, from <http://www.kinze.com/feature.aspx?id=253b306e-160a-40a3-aa66-1062e537dbf1&name=brush-type+seed+meters>
- Manufacturing, K. (n.d.). Computerized smart sensor. Robert's Farm Equipment. Retrieved from <http://robertsfarm.com/Kinze/adid/13497151/>
- Murray, J., Tullberg, J., & Basnet, B. (2006). *Planters and their components: Types, attributes, functional requirements, classification and description*. (A. Burgi, Ed.) Canberra, Australia: Australian Centre for International Agricultural Research.
- Planting, P. (n.d.). Precision meter. Retrieved April 26, 2017, from <http://www.precisionplanting.com/#products/precisionmeter/>
- Precision Planting. (n.d.). MeterMax ultra test stand operator's manual. Retrieved April 26, 2017, from <https://www.yumpu.com/s/MuN5yr3VJposADmw>
- Radtke, I. (2016). *USA Patent No. US20160212932 A1*. Retrieved from <http://www.google.us/patents/US20160212932>
- Rans, M. J. (2015). *USA Patent No. US20150237793 A1*. Retrieved from <https://www.google.com/patents/US20150237793>
- Sauder, G. A., Dill, K. R., & Dunlap, D. L. (2004). *USA Patent No. US6681706 B2*. Retrieved from <https://www.google.com/patents/US6681706>
- Sayler, T. (2006, January 15). Improving plant stands. National Sunflower Association. Retrieved from <https://www.sunflowernsa.com/magazine/articles/default.aspx?ArticleID=3086>
- Seeders, S. P. (n.d.). Belt planter metering unit. Retrieved April 26, 2017, from <http://stanhay.com/binary/2s.pdf>
- Smith, J. A., & Kocher, M. F. (2008). Evaluate planter meter and seed tube systems for seed spacing performance of confection sunflower seed to improve plant spacing in the field. National Sunflower Association. Retrieved from [https://www.sunflowernsa.com/uploads/research/330/Smith\\_PlanterMeter\\_08.pdf](https://www.sunflowernsa.com/uploads/research/330/Smith_PlanterMeter_08.pdf)
- Stephens, L. E., Keaton, M. R., Roman, R. J., & Valdez, J. M. (2008). *USA Patent No. US7343868 B2*. Retrieved from <https://www.google.com/patents/US7343868>

Thiemke, D. B. (2003). *USA Patent No. US6651570 B1*. Retrieved from <https://www.google.com/patents/US6651570>

Yeon, J. (2000). A seed transport and delivery mechanism for the revolving spade planter. University of Florida. Retrieved from <http://ufdc.ufl.edu/AA00003590>

## APPENDIX

**Table A1. Test results of optimized treatments for seed tube.**

Trt.	Plan'g Spd. (km h <sup>-1</sup> ) [mph]	Rep.	Seed Population (seeds ha <sup>-1</sup> ) [seeds acre <sup>-1</sup> ]	Sing'n (%)	Skips (%)	Mult's (%)	SRI (Mid) (%)	SRI (Bot) (%)
1	8.2 [5.1]	1	43243 [17500]	98.8	0.6	0.6	6.9	9.3
		2	42996 [17400]	98.8	1.0	0.2	9.5	11.9
		3	43243 [17500]	97.8	1.0	1.2	8.2	9.8
		4	43243 [17500]	97.6	1.2	1.2	10.3	11.9
		5	43490 [17600]	98.6	0.4	1.0	6.7	9.2
2	9.7 [6.0]	1	43243 [17500]	97.8	1.2	1.0	7.9	9.8
		2	42996 [17400]	98.6	1.0	0.4	8.4	10.8
		3	42996 [17400]	99.2	0.6	0.2	9.5	10.0
		4	42749 [17300]	97.8	1.6	0.6	7.8	9.6
		5	43243 [17500]	98.2	1.0	0.8	8.7	11.2
3	11.1 [6.9]	1	43243 [17500]	99.0	0.4	0.6	8.0	10.4
		2	43490 [17600]	98.6	0.4	1.0	8.3	10.5
		3	42996 [17400]	98.8	0.8	0.4	8.5	10.5
		4	42996 [17400]	98.4	1.0	0.6	11.9	13.2
		5	43490 [17600]	98.8	0.4	0.8	13.7	14.2
4	12.7 [7.9]	1	43243 [17500]	98.6	0.6	0.8	6.8	9.5
		2	43490 [17600]	97.6	0.8	1.6	8.8	11.0
		3	42996 [17400]	98.0	1.2	0.8	9.6	12.9
		4	43243 [17500]	99.2	0.4	0.4	9.2	12.2
		5	43243 [17500]	97.8	1.0	1.2	10.1	13.2
5	14.2 [8.8]	1	42749 [17300]	98.0	1.6	0.4	12.3	15.4
		2	43243 [17500]	96.8	1.6	1.6	10.6	13.4
		3	43737 [17700]	98.6	0.2	1.2	11.1	14.2
		4	42996 [17400]	98.0	1.2	0.8	12.5	15.7
		5	43243 [17500]	98.8	0.6	0.6	10.7	14.0
6	16.4 [10.2]	1	42996 [17400]	98.2	1.2	0.6	11.5	14.8
		2	43243 [17500]	97.8	1.2	1.0	12.1	16.0
		3	42749 [17300]	97.2	2.0	0.8	12.2	15.3
		4	42996 [17400]	98.2	1.2	0.6	13.7	16.4
		5	43243 [17500]	99.2	0.4	0.4	12.5	15.9

This table shows test results of 6 treatments (Trt.) and 5 replications (Rep.). Independent variable was planting speed and dependent variables were seed population, singulation, skips, multiples rates, and SRI for both middle and bottom sensors.

**Table A2. Test results of treatments for the new seed delivery system.**

Trt.	Plan'g Spd. (km h <sup>-1</sup> ) [mph]	Step. Mot. Spd. (steps sec. <sup>-1</sup> )	Rep.	Seed Pop'n (seeds ha <sup>-1</sup> ) [seeds acre <sup>-1</sup> ]	Sing'n (%)	Skips (%)	Mult's (%)	SRI (Top) (%)	SRI (Bot) (%)
1	8.2 [5.1]	1904	1	46703[18900]	92.0	0.0	8.0	18.9	25.8
			2	46703[18900]	92.2	0.2	7.6	18.8	24.1
			3	45714[18500]	94.6	0.0	5.4	16.5	23.2
			4	46950[19000]	92.4	0.2	7.4	19.5	24.9
			5	47444[19200]	90.6	0.2	9.2	19.4	25.9
2	8.2 [5.1]	1905	1	47444[19200]	90.6	0.0	9.4	20.4	23.9
			2	47938[19400]	89.8	0.2	10.0	19.9	25.5
			3	46456[18800]	93.6	0.0	6.4	20.5	26.2
			4	46950[19000]	92.4	0.0	7.6	18.5	24.4
			5	47444[19200]	90.6	0.0	9.4	18.6	26.4
3	9.7 [6.0]	2240	1	46209[18700]	93.4	0.2	6.4	19.7	26.3
			2	46209[18700]	92.6	0.2	7.0	19.9	26.8
			3	48433[19600]	89.2	0.0	10.8	22.2	25.2
			4	46950[19000]	91.8	0.0	8.2	19.8	24.9
			5	47197[19100]	91.0	0.6	8.4	21.1	26.1
4	9.7 [6.0]	2241	1	46950[19000]	92.0	0.0	8.0	20.9	25.9
			2	47938[19400]	91.0	0.0	9.0	20.8	27.1
			3	47938[19400]	89.2	0.4	10.4	22.0	26.7
			4	46456[18800]	93.0	0.2	6.8	19.9	25.7
			5	47197[19100]	90.8	0.2	9.0	24.5	26.5
5	11.1 [6.9]	2577	1	45714[18500]	93.8	0.4	5.8	21.4	25.5
			2	48680[19700]	88.4	0.0	11.6	19.6	24.7
			3	48433[19600]	88.8	0.0	11.2	20.2	26.8
			4	47691[19300]	90.2	0.0	9.8	17.7	26.6
			5	49668[20100]	87.8	0.0	12.2	28.4	31.7
6	11.1 [6.9]	2578	1	47691[19300]	90.2	0.0	9.8	20.3	25.8
			2	47197[19100]	91.0	0.2	8.8	18.6	25.7
			3	46703[18900]	92.2	0.0	7.8	18.7	25.7
			4	47691[19300]	90.0	0.2	9.8	22.2	26.7
			5	46950[19000]	91.4	0.2	8.4	19.8	26.6

This table shows test results of 6 treatments (Trt.) and 5 replications (Rep.). Independent variables were planting speed and stepper motor speed and dependent variables were seed population, singulation, skips, multiples rates, and SRI for both top and bottom sensors.

57

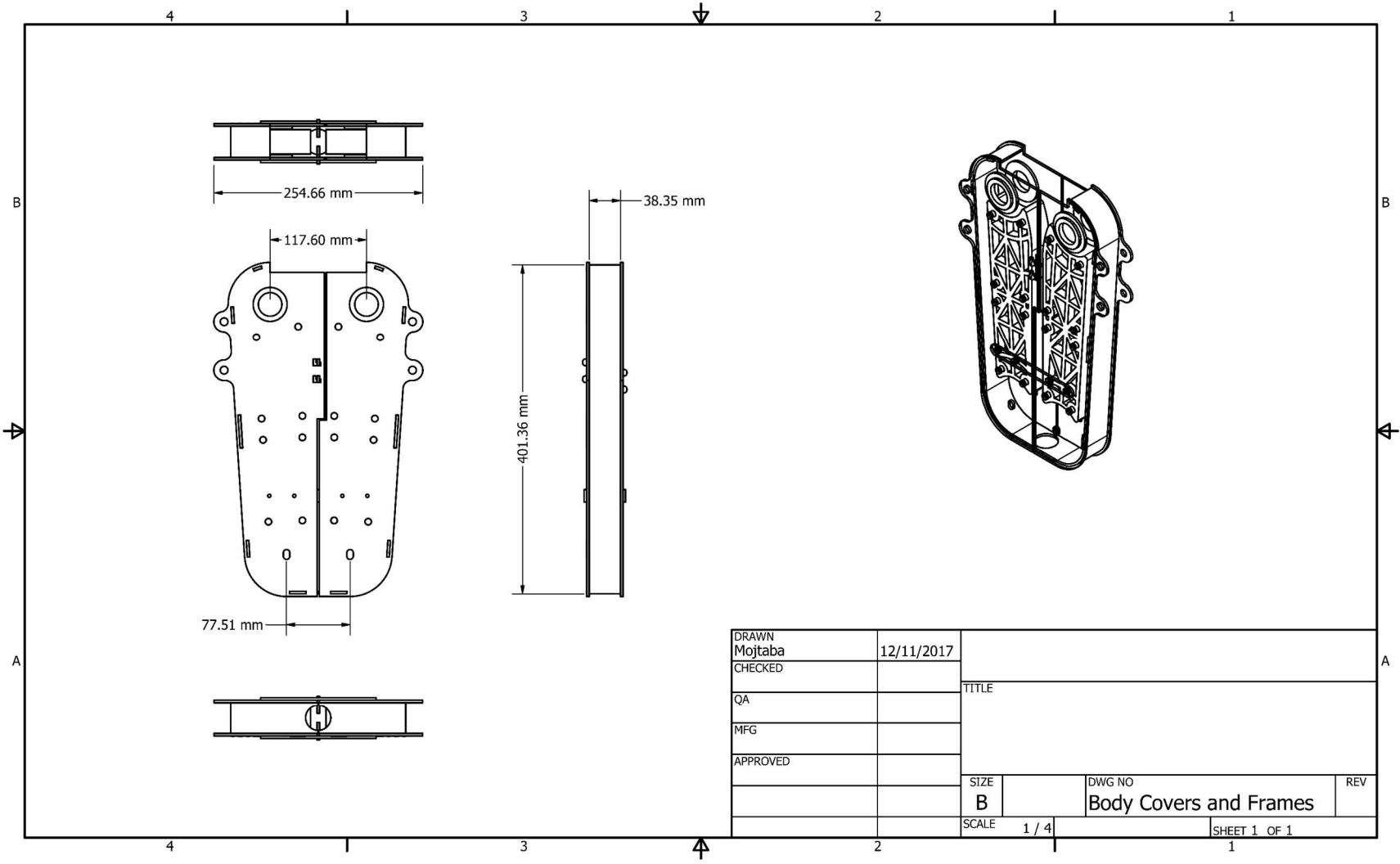


Figure A1. Assembly of steel body covers, 3D printed body frames, and guiding nubs.

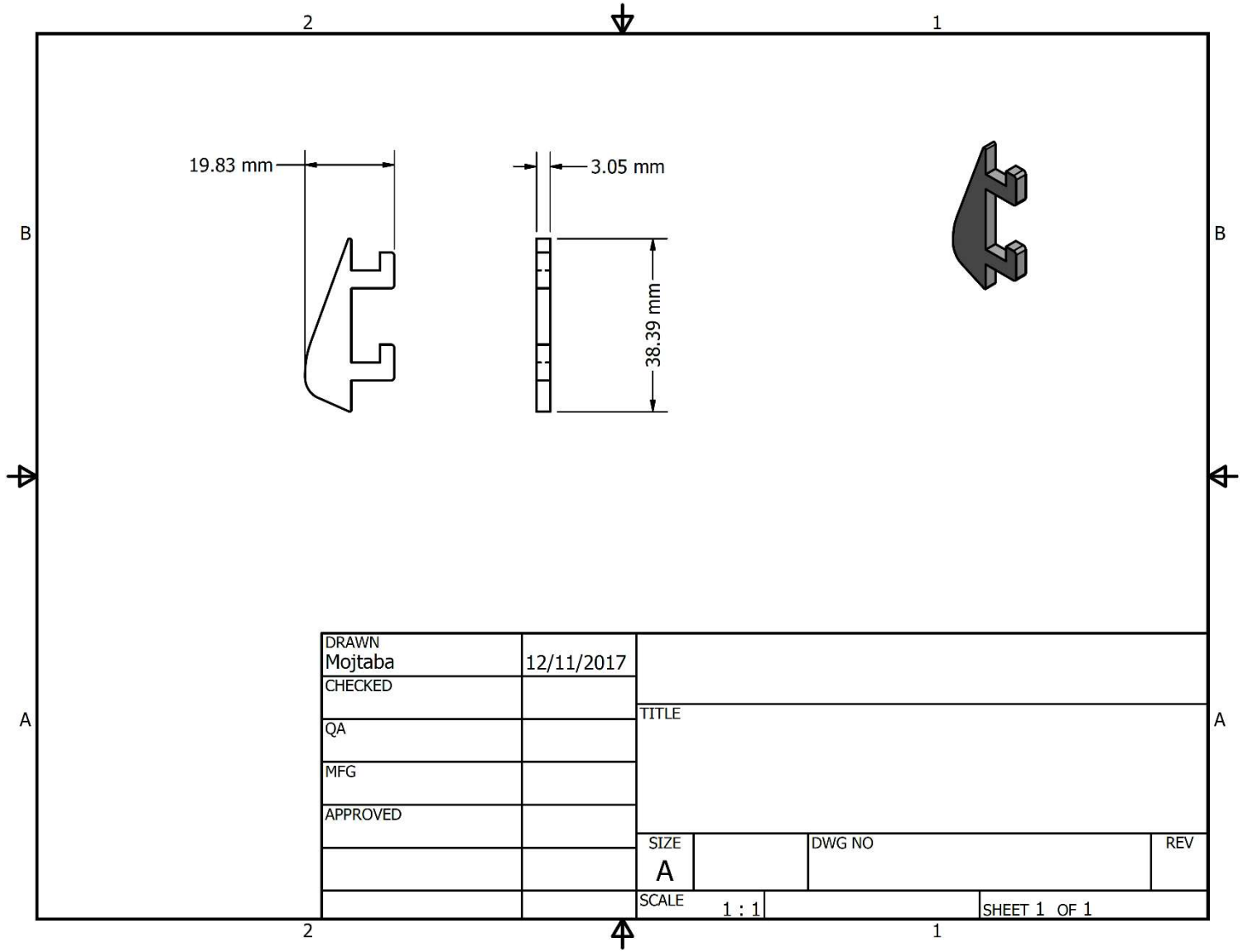


Figure A2. Guiding nub.

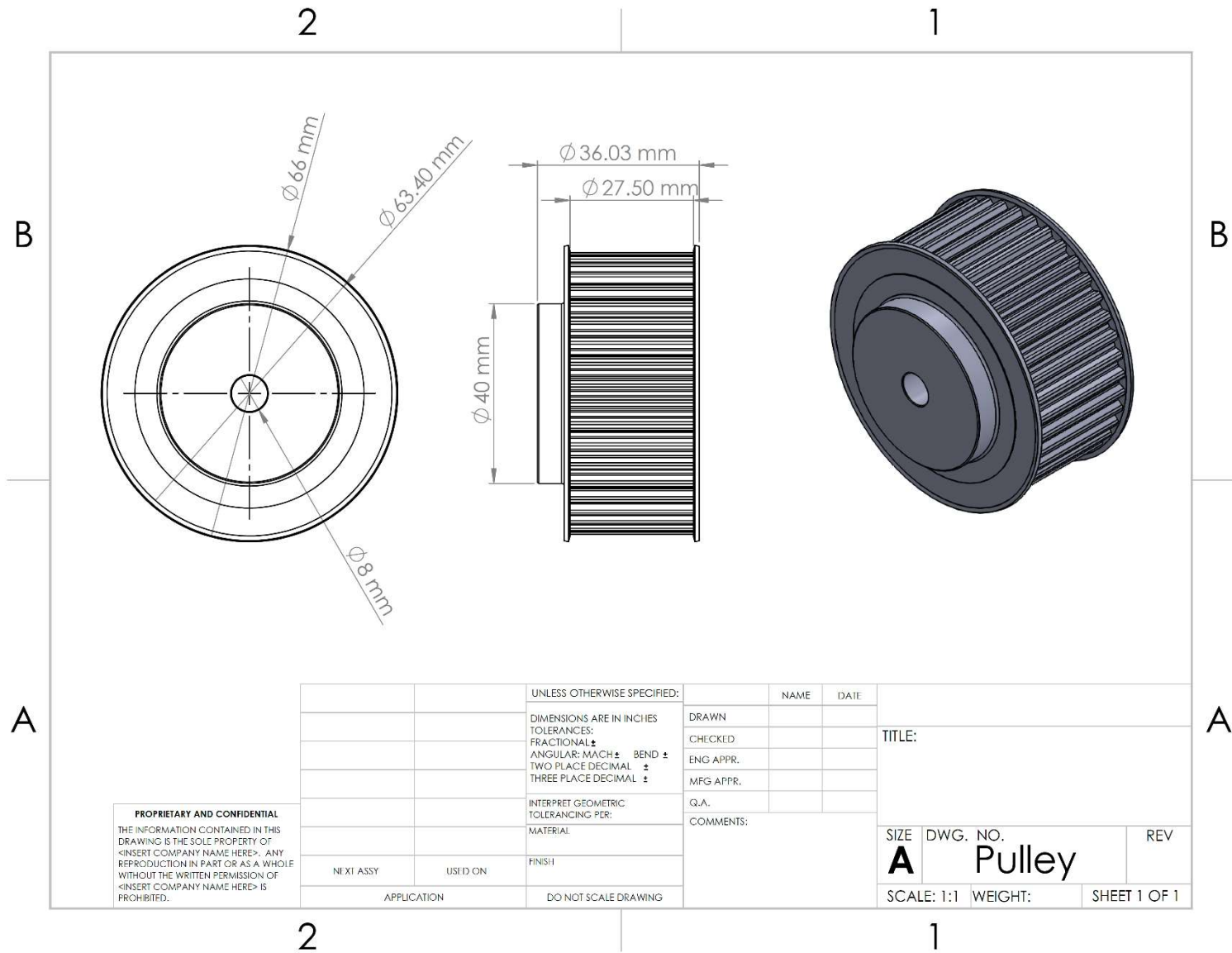


Figure A3. Aluminum pulley.

09

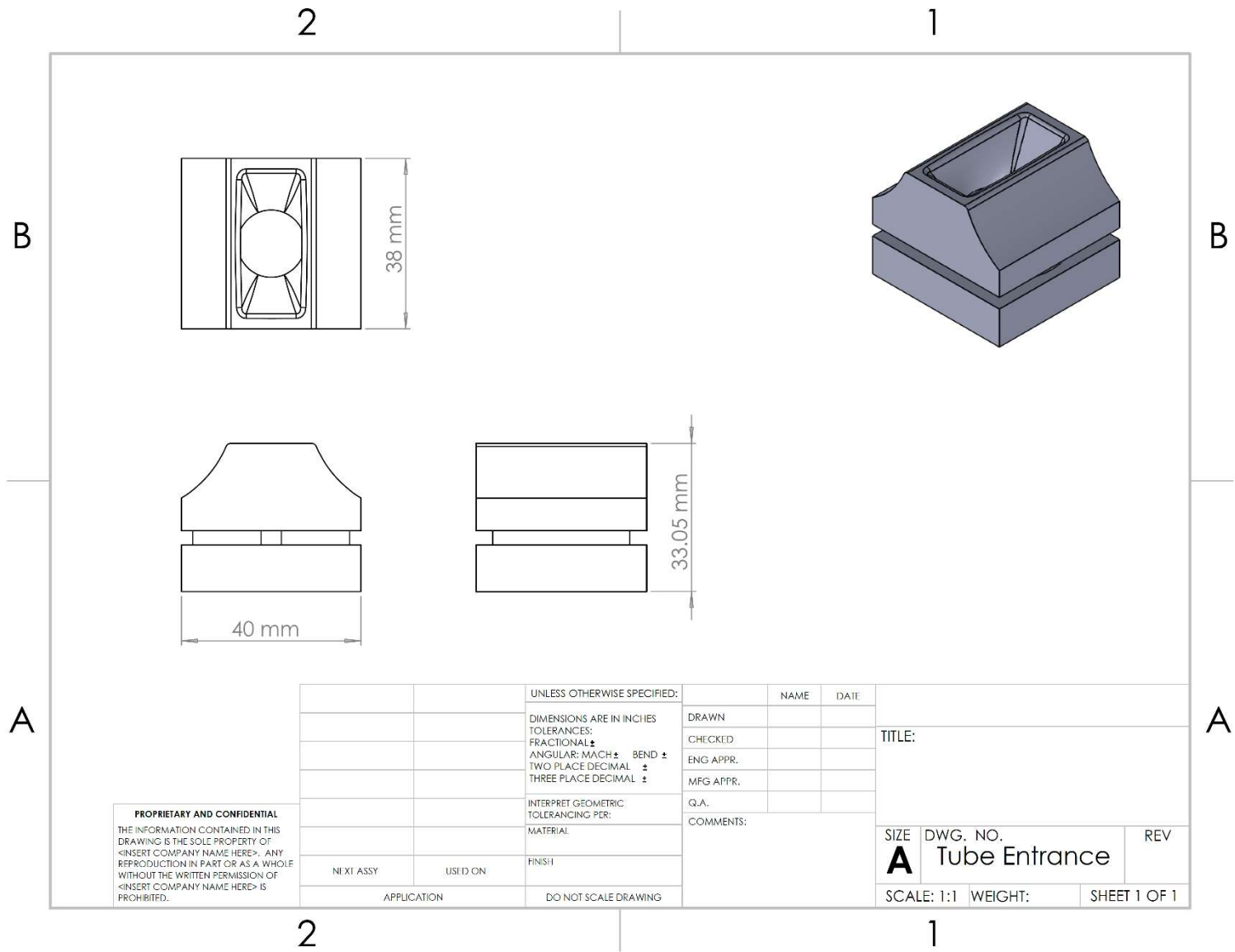


Figure A4. Bottom tube entrance.



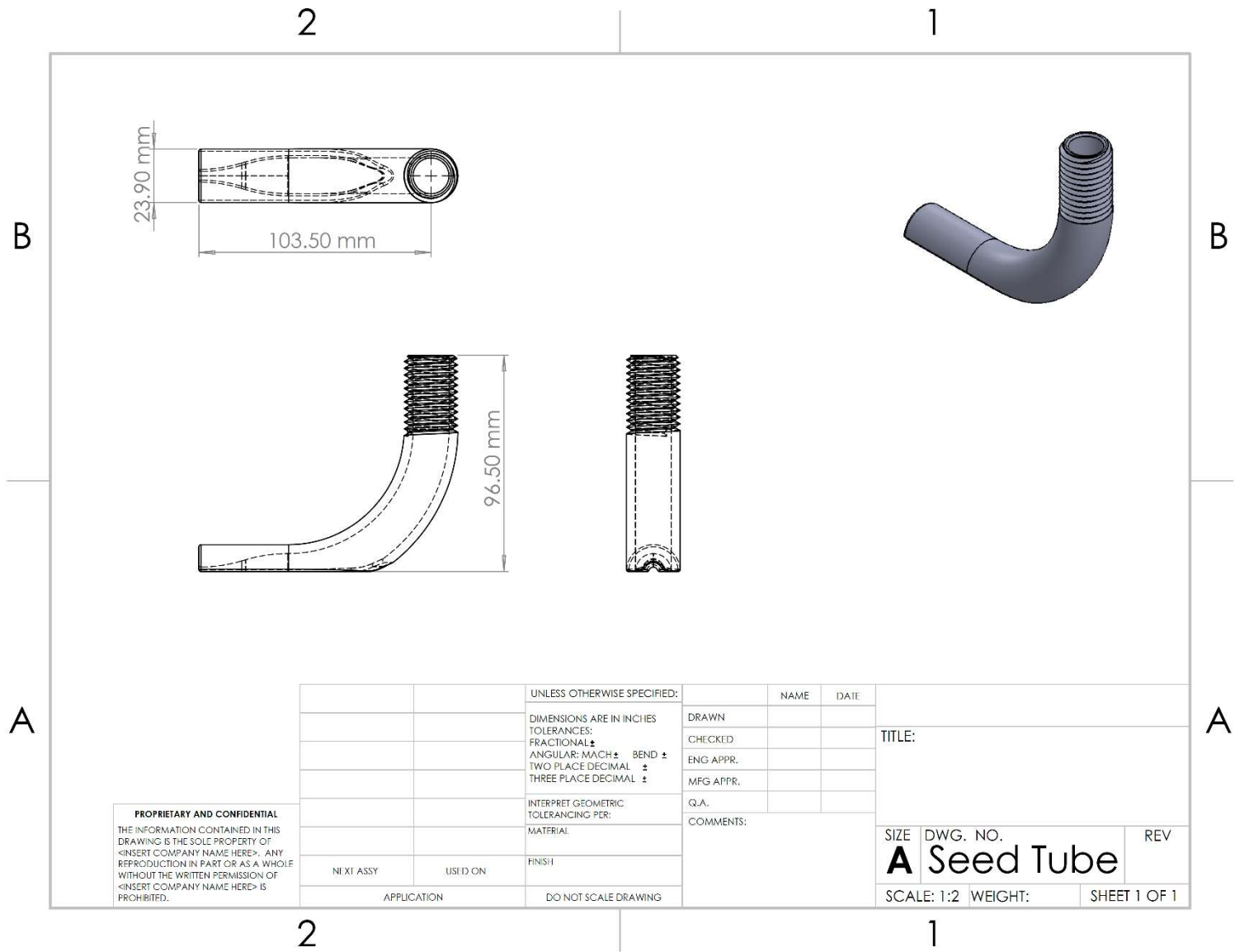


Figure A5. Bottom seed tube.

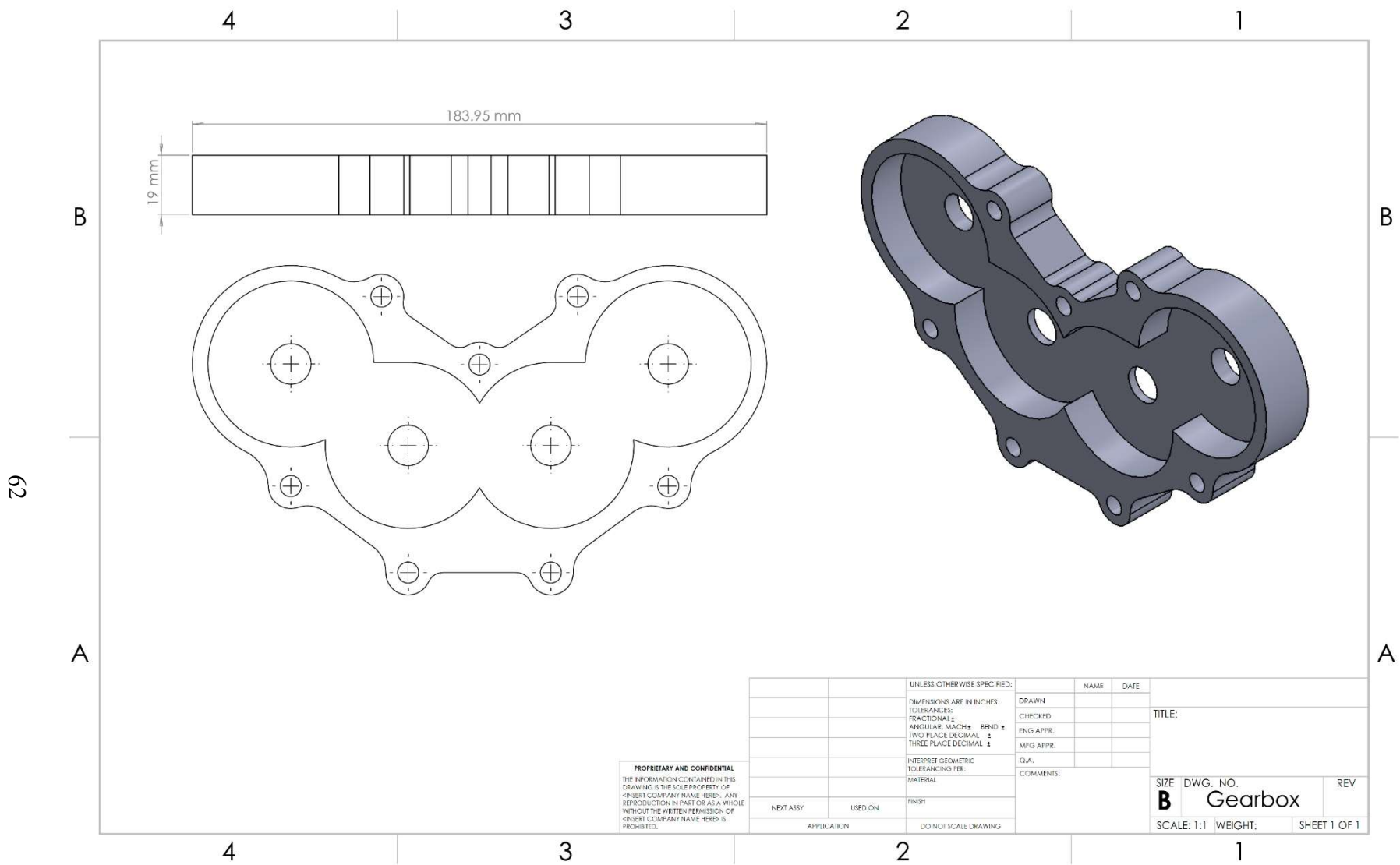


Figure A6. Gear set housing.

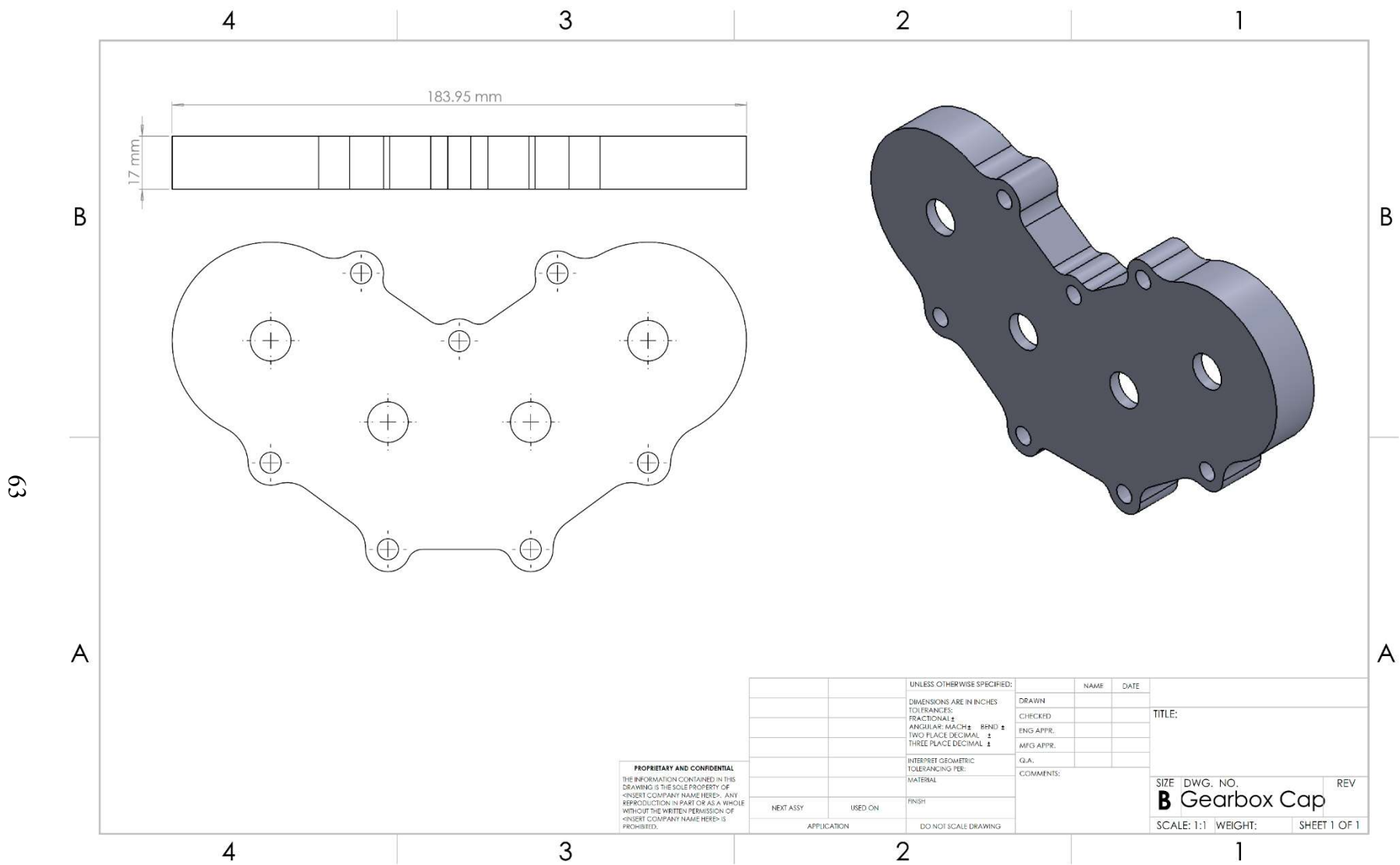


Figure A7. Gear set housing cap.

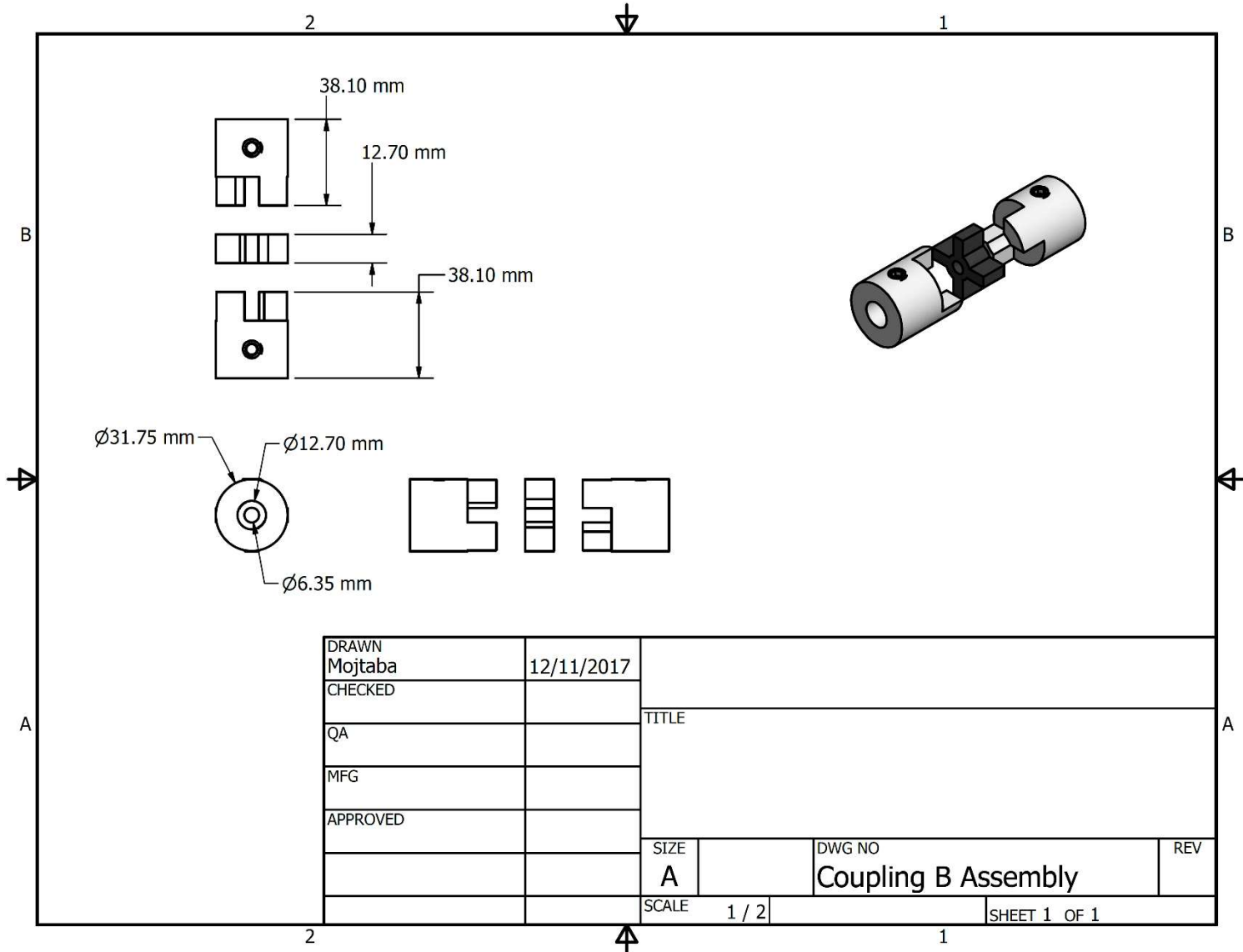


Figure A8. Coupling assembly.