

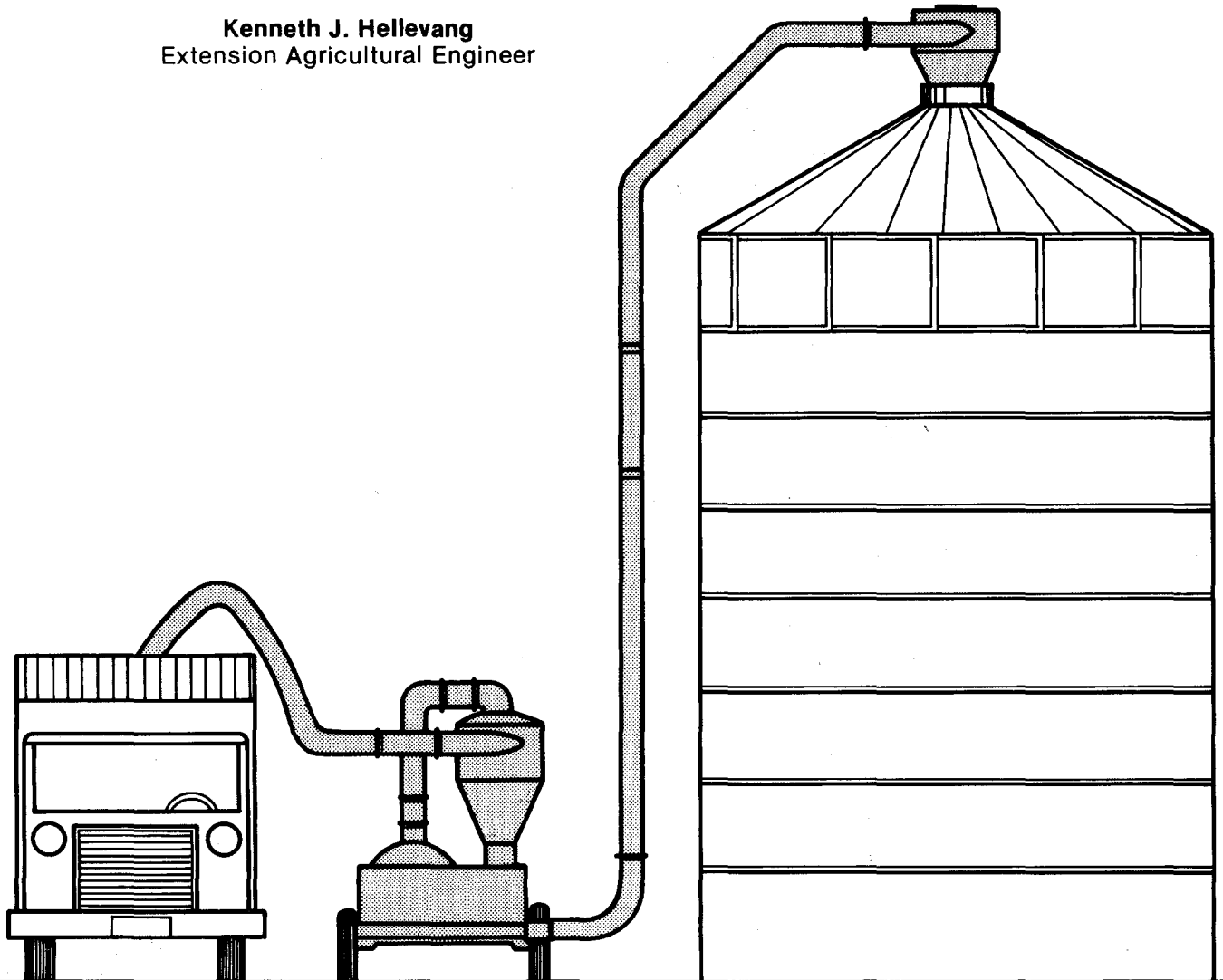

NORTH DAKOTA  
STATE UNIVERSITY  
JUL 18 1985  
SERIALS DEPT.  
LIBRARY

# Pneumatic Grain Conveyors

Kenneth J. Hellevang  
Extension Agricultural Engineer



S  
44.3  
✓ 9  
78x  
850

A pneumatic conveyor moves grain in a closed duct using air.

Advantages of pneumatic grain conveying include:

- Flexibility of installation and use,
- Mechanical parts are at ground level,
- Self cleaning,
- Less safety hazard at grain intake than with an auger, and
- Reduces dust in suction area.

Disadvantages include:

- High power requirement for the capacity moved,
- Noise can be a problem.

Pneumatic conveying systems can be developed into a completely interconnected, ready-to-go, push-button grain conveying system. They are especially adaptable to systems that need relatively low grain conveying capacity and where the material is to be conveyed long distances (greater than 100 feet).

There are two types of pneumatic systems—positive pressure (push units) and negative pressure (vacuum) units. Many pneumatic conveyors use both positive and negative pressure. Grain is vacuumed from a bin, then pushed into a

truck or storage (Figure 1). Air is pulled by the blower through the air intake near the grain nozzle. The blower pulls the grain and air to the cyclone, where the grain and air are separated; then the air is pulled through a screen into the blower and is blown out to pick up the grain again. The grain drops down in the cyclone and is metered through the air lock into the air coming from the blower. Both the air and grain flow through the pipe to the discharge cyclone where the grain is slowed and allowed to drop out the bottom. The air exhausts through the top of the cyclone. A cyclone separator at the termination point may not be used in all applications.

A positive pressure unit is shown in Figure 2. This type of pneumatic conveyor has a blower unit to push air and grain through the pipe. Grain is metered into the airstream through an air lock. The air lock is needed to move grain into the airstream and to prevent air from leaking out.

## Blowers

A pneumatic conveyor can operate with a small volume of air at high pressure or with a large volume of air at a lower pressure. There is approximately the same amount of energy in 1,000 cubic feet per minute (cfm) at 1 pound per square inch pressure as in 100 cfm at 10 pounds per square inch pressure.

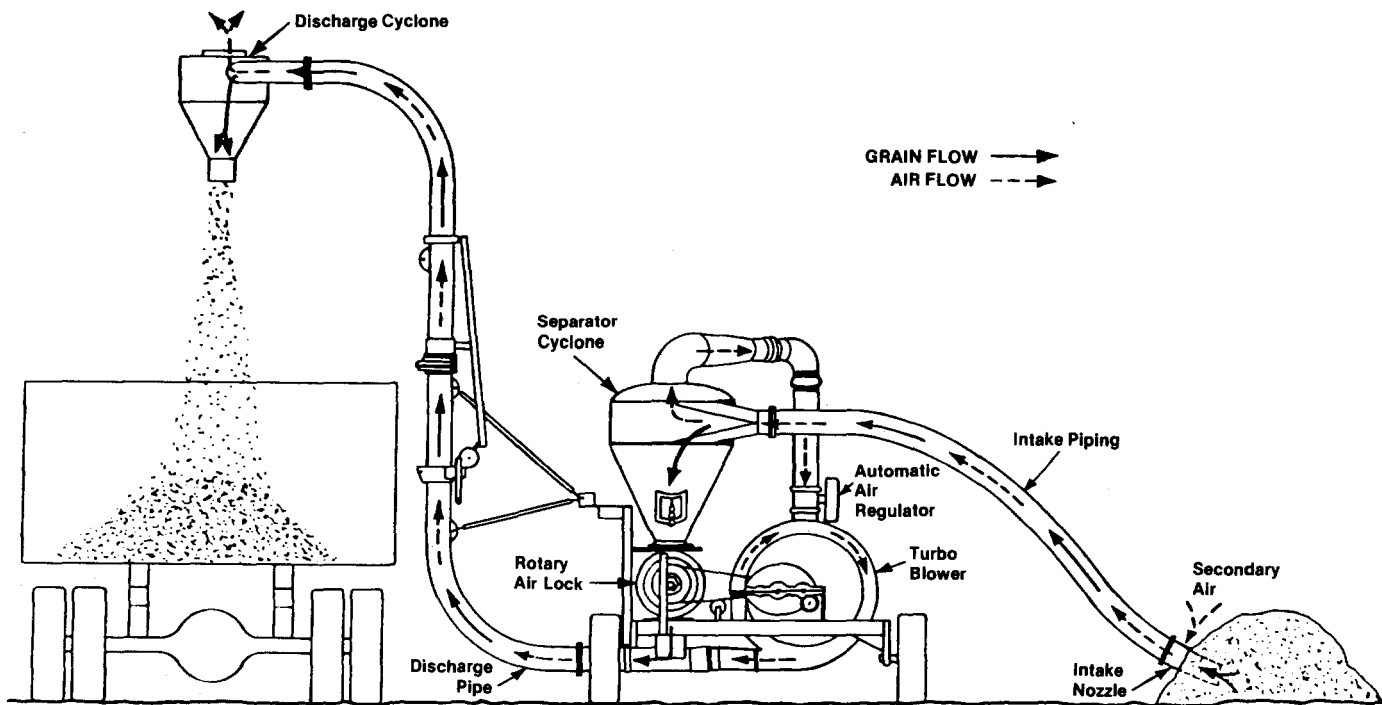

Figure 1. Positive and negative pressure pneumatic grain handling system.

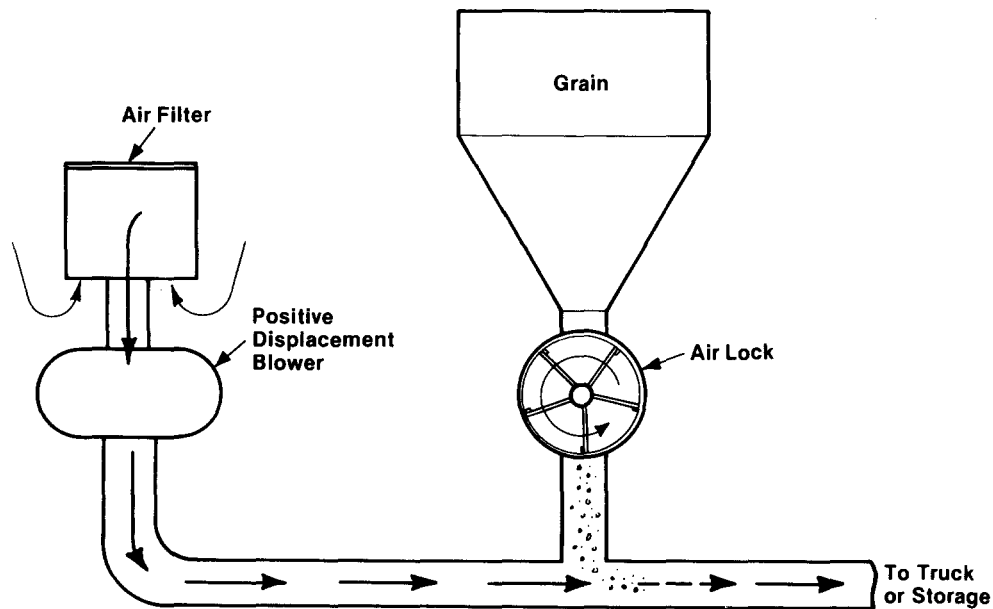

Figure 2. Positive pressure pneumatic grain handling unit.

A rotary positive displacement blower (Figure 3) pumps air by rotating a pair of lobed rotors within a housing so that the rotor lobes mesh with each other similar to the teeth on a pair of gears. The positive pumping action obtained by the intermeshing lobes permits this type of blower to develop up to 10 to 12 pounds per square inch (psi) pressure in a single stage. The positive displacement blower delivers a nearly constant volume of air but takes more power when operating against increased resistance (a higher pressure).

A pressure relief valve and vacuum relief valve are needed with positive displacement blowers to prevent developing very high pressures that could damage the unit. A filter is very important because dirt in the air may damage the blower.

Where large quantities of product are to be moved, the ability of the positive displacement blower to develop higher pressures becomes important. This permits the system to handle more product with less air through smaller pipes. High pressure, low air volume systems using positive displacement blowers may be operated without a cyclone separator.

A centrifugal blower (Figure 4) delivers large volumes of air at low pressure. A single blower can produce up to about 4.0 psi pressure. Blowers may be connected in series forming a multistage unit that will develop higher pressures. The centrifugal

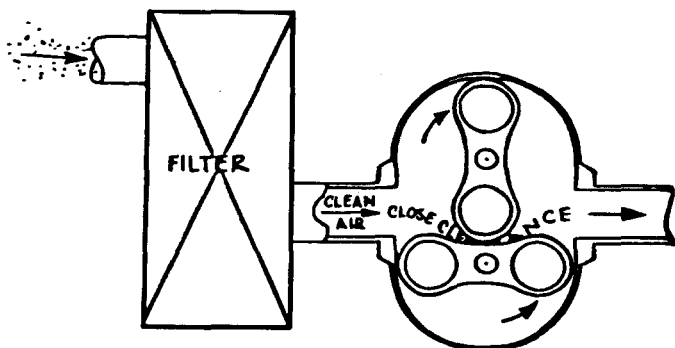

Figure 3. Rotary Positive Displacement Blower

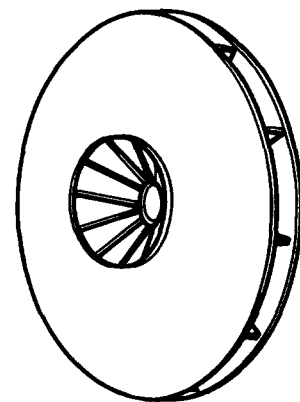

Figure 4. Centrifugal Blower

blower delivers less air and requires less power when operating against high resistance than against low resistance. Centrifugal systems usually use a cyclone separator at the discharge to reduce the grain velocity. Regulators are needed to reduce airflow when conveying rates are low. The horsepower requirement decreases as grain flow increases. A centrifugal unit generally requires more horsepower than a positive displacement unit for the same conveying capacity. The centrifugal blower is more tolerant of dirt, which is an advantage when used with negative pressure units.

A negative pressure unit that sucks air into the fan may also suck in lint and other fines. This is especially troublesome when moving sunflower. This can cause a buildup on the fan, screen or filter, and cyclone separator. The buildup can become severe enough to stop the fan. Because of this, having access to these areas for cleaning is important.

### Air Lock

The air lock (Figure 5) meters the grain into the airstream while forming an air seal to prevent airflow through the air lock. The speed of rotation of the air lock regulates the grain flow rate. Excessive rotation speeds may damage the grain and cause plugging. Large air locks turn slower and generally last longer. Some air locks are adjustable.

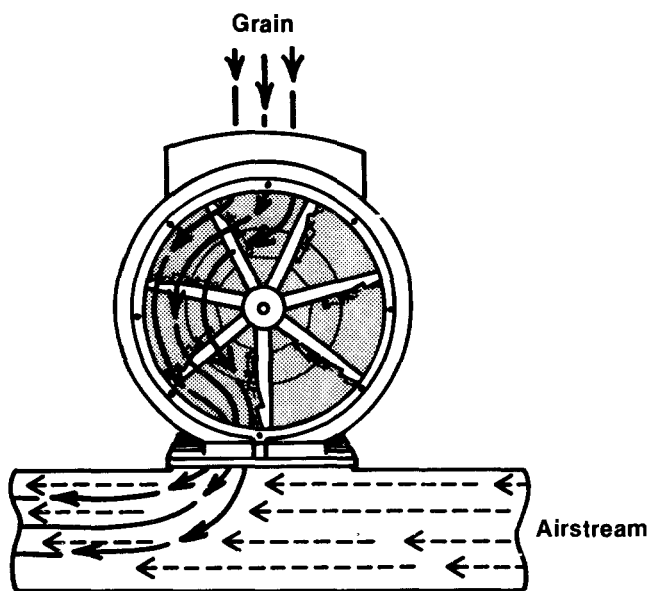

Figure 5. Rotary Air Lock

### Cyclone Separator

A cyclone separator (Figure 6) slows the grain and separates the grain from the air. A screen or filter is normally used on the air exhaust if the air is going to the fan. Conveying capacity will be reduced as the filter or screen becomes dirty.

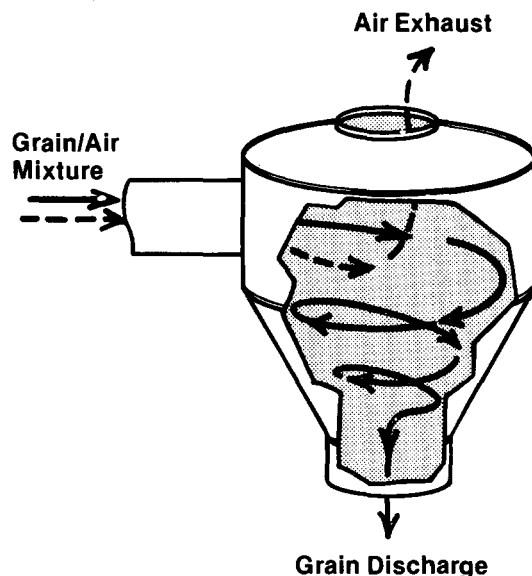

Figure 6. Cyclone Separator

### Pipe and Fittings

Pipe should be resistant to abrasive wear. Pipe connections should have a smooth inner surface to minimize grain damage and reduce pipe wear. Any change in direction (bends) will reduce the flow rate and increase grain damage and pipe wear. The turning radius should be a minimum of six to eight times the tube diameter for bends of 45 degrees or more. Long radius turns cost more but the pipe lasts longer due to reduced abrasion by the grain and flow resistance is minimized.

Static electricity is caused by grain rubbing on the pipe. This may "shock" operators or cause explosions in dusty conditions. The pipe should be grounded to eliminate this problem.

Plugging problems must be considered. The pneumatic conveyor will generally clean itself when plugged if more grain is not added. However, it may be necessary to manually clean the pipe when severely plugged.

## Power Requirement and Capacity

Conveying rate depends on pounds of grain and air moved and the physical characteristics of the grain. Pneumatic grain conveying normally requires a large power source. If a presently owned tractor is available, this may not be as important as when another engine or electric motor must be purchased. However, the energy cost to move a bushel of grain will still be higher with a high horsepower unit than with a low horsepower unit.

Approximate capacity, as listed by manufacturers, for two positive and negative pressure units, one a 75-horsepower turbo-blower and the other a 50-horsepower positive displacement blower, are shown in Tables 1 and 2.

**Table 1. Approximate horizontal conveying capacity; 75-hp, 6-inch pipe, turbo-blower**

Horizontal Distance in Feet	Horizontal Distance				
	25	100	200	300	
Bushels per hour	Wheat	1400	990	845	735
	Corn	1700	1200	1000	850

Capacity listed by manufacturer.

**Table 2. Approximate horizontal conveying capacity; 60-hp, 5-inch pipe, positive displacement blower.**

Horizontal Distance in Feet	Horizontal Distance				
	50	100	200	300	
Bushels per hour	Wheat	2200	1500	1150	900
	Corn	2400	1700	1300	1000

Capacity listed by manufacturer.

The effect of a vertical lift and bends were demonstrated at an NDSU Agricultural Engineering Field Day. Grain was conveyed vertically 40 feet, went through two 90 degree turns, returned to ground level, and then lifted into a truck through 100 feet of pipe. The same amount of grain was also conveyed 100 feet horizontally and up 10 feet into the truck. The power unit was a farm tractor. A comparison is shown in Table 3.

**Table 3. Pneumatic conveying time and fuel comparison.**

Lift	Time (minutes)	Fuel Used (pounds)
10 ft.	2.75	1.80
40 ft. and 10 ft.	3.00	2.14
Percent change	9%	19%

The approximate capacity of a 15-hp positive pressure unit is shown in Table 4.

**Table 4. Capacity (bu/hr) of a 15 hp positive pressure pneumatic unit moving corn.\***

Vertical Distance	Horizontal Distance							
	25'	50'	75'	100'	125'	150'	175'	200'
100'	714	684	653	622	593	564	537	510
80'	758	726	692	660	628	598	569	541
60'	805	772	735	700	667	635	604	574
40'	858	821	787	745	709	675	642	610
20'	915	876	833	793	755	718	682	649

\* Capacities are based on a system with a total of 180 degrees of bends in the conveying lines, corn weighing 56 pounds per bushel at 15.5% moisture content at sea level. Conveying rates for other grains will generally be within 80% to 110% of corn rates. Data is based on a constant supply of free-flowing grain available at the suction nozzle.

A 75-horsepower positive and negative pressure unit with 6-inch pipe was tested by the Prairie Agricultural Machinery Institute, (PAMI), Canada, in 1979, Report No. E1878. The specific capacity, bushels per horsepower hour, for a 7-inch auger was five times greater than that of the pneumatic unit in wheat, four times greater in oats, and 3.5 times greater in rapeseed. The manufacturer reports capacity has been improved 10 percent since the test.

The PAMI test results, Report No. E1176, 1977, for an 80-horsepower positive and negative pressure unit with 8-inch pipe are listed in Table 5.

**Table 5. Comparison of 80-hp, positive and negative pressure, 8-inch pipe pneumatic unit to a 6-inch diameter grain auger.**

Grain Type	Maximum Conveying Rates		Specific Capacities	
	pneumatic unit (t/h)	6 in. auger* (bu/hr)	pneumatic unit (bu/hph)	6 in. auger* (bu/hph)
Wheat	27.7	1,015	41.5	1,520
Barley	26.7	1,225	30.8	1,415
Oats	36.9	2,390	24.1	1,560

\* The grain auger data was obtained from Agricultural Machinery Administration Test Report No. 1860.

## Grain Damage

Prairie Agricultural Machinery Institute tests have found wheat crackage to be about 0.25 percent for

each pass through a pneumatic unit, which is similar to damage caused by grain augers. A 1983 Purdue University study showed that corn damage increases with increased velocity. USDA tests showed the same with white navy beans (Table 6).

**Table 6. Damage when conveying white navy beans with a pneumatic conveyor, USDA Bulletin No. 1315.**

Seed Velocity (fpm)	Germination (%)	Visible Breakage (%)
0-Control	93.4	0.00
650	91.0	0.40
960	89.7	0.49
1,445	83.5	0.59
1,660	82.7	0.70
2,265	73.5	1.62

Damage due to the air lock was also considered in USDA tests conveying white navy beans (Table 7).

**Table 7. Damage conveying white navy beans with pneumatic conveyor.**

Breakage due to	Conveying	
	Dense Phase* (%)	Lean Phase* (%)
Air Lock	1.03	0.27
Transport	0.52	1.35
TOTAL	1.55	1.62

\* Dense Phase-high grain-air ratio

\* Lean Phase-low grain-air ratio

Transport damage was higher for lean phase (low grain-to-air ratio) conveying than for dense phase. However, the air lock damage in this study was higher for the dense phase. In the dense phase conveying, each compartment of the air lock tended to operate with a nearly full load but to discharge only a small part of this load in any one revolution. As a result, some seeds were tumbled many times at or near the shearing edges of the air lock.

A pneumatic conveyor with a fan normally has higher velocities than one with a positive displacement pump. Research indicates the air velocity in high capacity pneumatic conveyors should not exceed 5,400 feet per minute to minimize grain damage. Operators of pneumatic conveyors report that maintaining the recommended volume of air-to-grain is important for good conveyor performance and to minimize grain damage.

Damage can be reduced by using large radius turns and as few turns as possible. A minimum radius of six to eight times the tube diameter is recommended.

## Selecting a Handling System \_\_\_\_\_

It is important to:

- Examine your handling needs.
- Determine what is available.
- Examine other systems and visit with users.
- Develop a plan.
- Compare investment and use costs.
- Check service availability.
- Finally purchase and install the handling system.

