

Home Made Nest Sites for Mallards

Terry A. Messmer
NDSU Extension Service

Michael A. Johnson
ND Game and Fish Department

Forrest B. Lee
Great Plains Wildlife Services

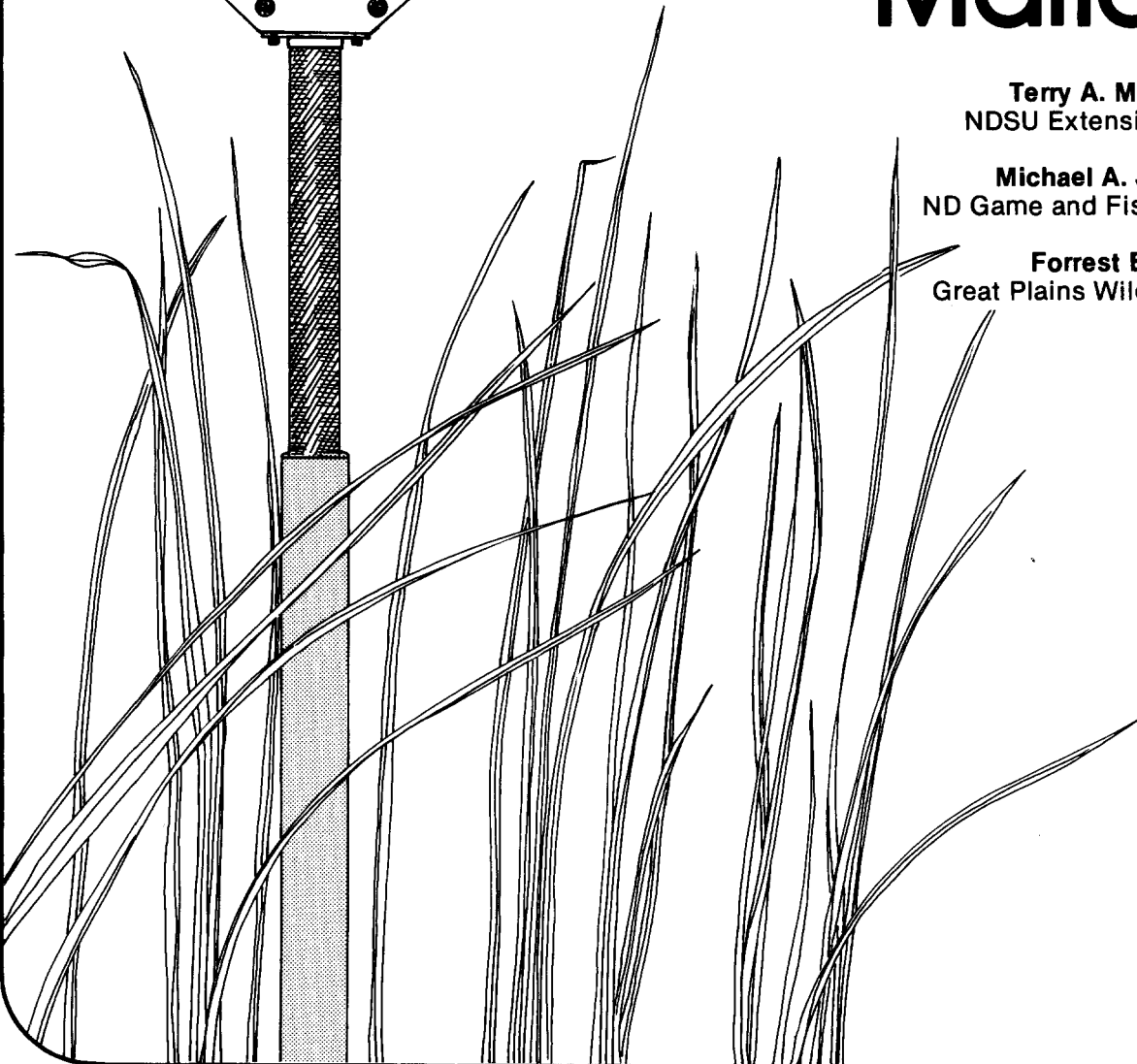

S
144.3
J9
A8
no. 890



NDSU EXTENSION SERVICE

North Dakota State University, Fargo, ND 58105

20WM-1

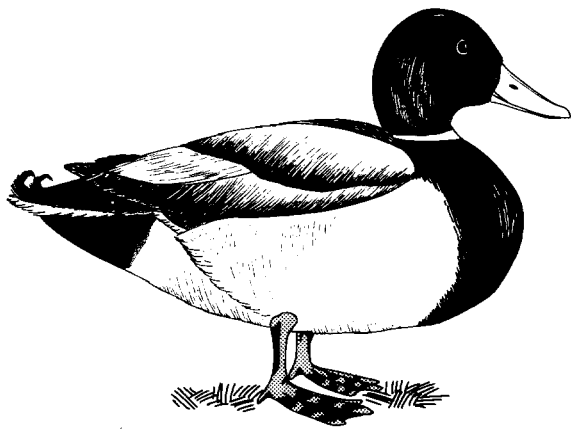

Mallard Drake

Nearly everyone who lives in North Dakota is likely to be familiar with the mallard duck, especially the "green head" drake. Mallards have long been a favorite of duck hunters as both a sport bird and excellent table bird. Non-hunters also enjoy these beautiful birds through the year.

This magnificent bird is now in trouble in North Dakota and elsewhere on its breeding grounds. The number of nesting mallards has dropped to but a fraction of its former abundance. This drastic decline is due to habitat loss and low nesting success. Studies of ground nesting mallards have indicated a nesting success of 20 percent or lower. This is due principally to the destruction of nests and nesting females by predators such as fox and raccoon. One way nesting success can be substantially increased is through the use of elevated nesting structures.

This circular contains information and plans for the construction, placement, and maintenance of two types of elevated nesting structures that you can use to increase mallard nesting success in your area.

Life History

The mallard nests in all parts of North Dakota where suitable parts wetland habitats exist. It breeds over much of North America from Alaska to New York State to California. Mallards also are found in some parts of northern Europe and Asia. Mallards are highly adaptable and can be found in prairie, forested, and urban environments.

The green head and white collar are distinguishing marks of the drake mallard in the spring. A chestnut vest and curled black feathers over the white tail adds to its handsome appearance. The hen is buff or light brown and the feathers are streaked with darker brown. Adult males lose their bright breeding plum-

age by the end of July and take on an eclipse plumage similar to that of the females. In fall and early winter male mallards again assume the same colorful plumage that they have in the spring. The mallard is a large duck and average weights range from 2¾ to 3 pounds.

The mallard is one of the earliest ducks to migrate into North Dakota in the spring. Usually many have arrived by the end of March, and peak numbers are present in the state in April. In the fall, locally raised mallards may congregate on the larger waterfowl marshes during late September and early October and often are present in the state until the time of the general freeze-up in November. Mallards often spend the winter as far north as open water and food supplies allow. In most winters, small flocks may be found along the Missouri River and other places in North Dakota. Major wintering areas, however, include reservoirs, flooded hardwood river bottoms and streams in the southern United States and Mexico.

The mallard is a surface feeder and is commonly observed tipping up to feed in shallow water. It also feeds on dry land, such as stubble fields where corn, wheat, barley, and other foods are available. In spring, the diet of the female is high in animal matter such as insects and other invertebrates, which are needed to sustain her during egg laying.

In her first nesting attempt, the female mallard commonly lays 10 or 11 eggs. If the clutch is destroyed she will often reneest. In reneests the clutch size is generally smaller and may range from seven to nine eggs. The eggs are dull in color and vary from light grayish buff to a light green. The incubation period is about four weeks.

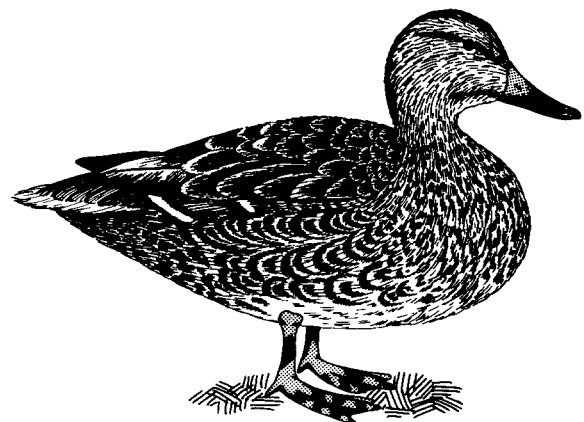

Mallard Hen

Newly hatched young are rich dark brown on the crown and back. The under parts and sides are pale to bright yellow. The first feathers appear on the sides of the duckling at about three weeks of age. The ducklings appear fully feathered in about seven weeks and may start flying at that age. In the newly hatched young, a high percentage of the diet is comprised of insects and other foods of animal origin. As the duckling grows older, more vegetable matter is eaten.

Most mallards will have attempted to nest by early May. Renesting attempts, if nests are destroyed, will take place after this date and may extend well into July. A wide variety of nesting sites are used by mallards, although they seem to prefer fairly dry sites with rather tall vegetation. Some hens will nest in marshes on muskrat houses or other over-water nesting situations. Islands also provide safe nesting sites for mallards.

NESTING BASKETS

The primary objective of a nesting basket project is to increase mallard production by inducing them to nest in a more secure site, thus reducing nest losses. In 1967, trials of basket nests on prairie marshes in east central North Dakota showed exceptionally high use (69 percent) and nesting success (89 percent) by mallards. Nesting basket projects need not be carried out only by state and federal wildlife agencies; it is a project for conservation organizations, youth groups, devoted individuals, public spirited industries, and others. The use of nesting baskets is environmentally acceptable since the structures are removable and do not permanently alter the landscape or marsh.

Two types of elevated nesting structures have been successfully used in North Dakota. These are wire basket structures and fiberglass structures. Both are of similar shape and design. Both types are accepted equally well by mallards, and Canada geese also occasionally nest in them. The wire baskets may cost less than the fiberglass structures; however, there is considerably less work involved in assembling the fiberglass unit.

Wire Basket Structure

The wire basket structure consists of two parts: the basket and the support pipe. The nest basket is 1/2-inch galvanized mesh cone (hardware cloth), 12 inches deep with a 26-inch diameter open top. It is wired to a frame of welded, 1/4-inch diameter steel rods which in turn are welded to a 24-inch length of pipe of a diameter that will fit snugly into a support pipe.

Materials Needed

- 1 7- or 8-foot length of 1 1/2-inch I.D. pipe
- 1 2-foot length of 1-inch I.D. pipe
- 1 11-foot length of 1/4-inch hot rolled steel rod
- 1 36-inch x 36-inch piece of 1/2-inch hardware cloth
- 1 3/8-inch x 1-inch N.C. capscrew

Construction

The wire cone is cut from 1/2-inch hardware cloth, 36 inches wide. The cloth is first cut into 36-inch squares, and then the 18-inch square unused portion is cut out (Figure 1). The cloth is then formed into a cone and is tied in this position with soft wire. The basket frame is constructed from a 24-inch section of 1-inch I.D. pipe and four 1/4-inch x 12-inch hot rolled steel rods. The 1/4-inch rods are welded to the pipe and then bent out to accommodate the basket frame rim as shown in Figure 2. An additional 82-inch length of steel rod is used to form the rim of the basket frame. The wire cone is inserted into the basket frame and the corners of the wire cone are bent down over the rim. The cone is fastened in place with soft wire.

The inside diameter of the basket frame pipe shown is 1-inch but can be changed to match the available material used for the nest support pipe. This pipe can fit either inside or outside the nest support pipe. If it is fitted outside the nest support pipe, two holes should be drilled opposite each other about 3 inches from the top and 1/4-inch or larger steel rod inserted to prevent the nest support pipe from punching through the bottom of the wire cone. The nest structure support may be any metal

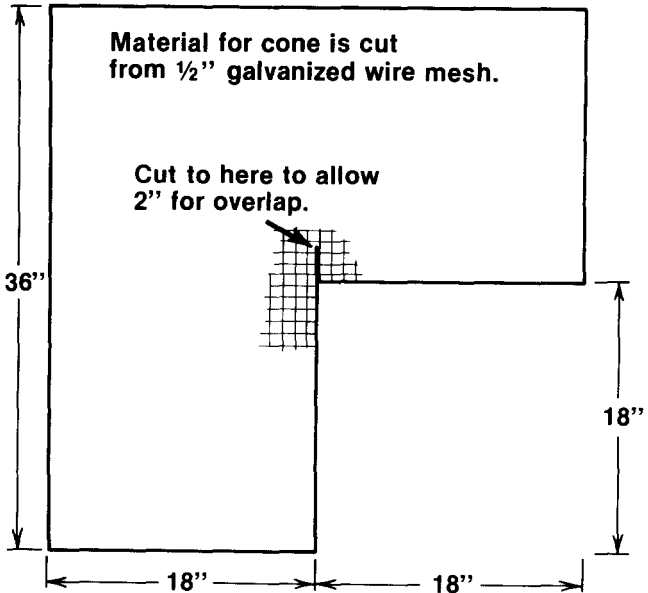

Figure 1. Wire basket pattern.

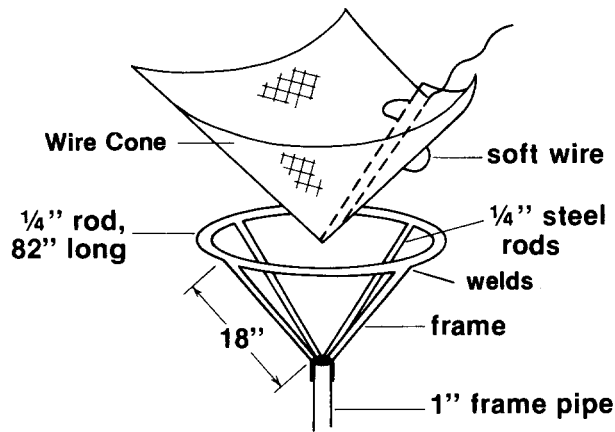

Figure 2. Wire basket assembly.

material available that is rigid enough to support the nest basket and attaching assembly. A smooth, round, non-corrosive pipe is preferred as it is harder for predators to climb.

A threaded hole for a setscrew should be tapped about 3 inches from the top of the support pipe. When tightened, this setscrew will give stability to the basket and permit raising or lowering it as water levels change from year to year. A 7- to 8-foot support pipe usually is satisfactory. The pipe length, however, will depend on the firmness of the marsh bottom and water depth (Figure 3).

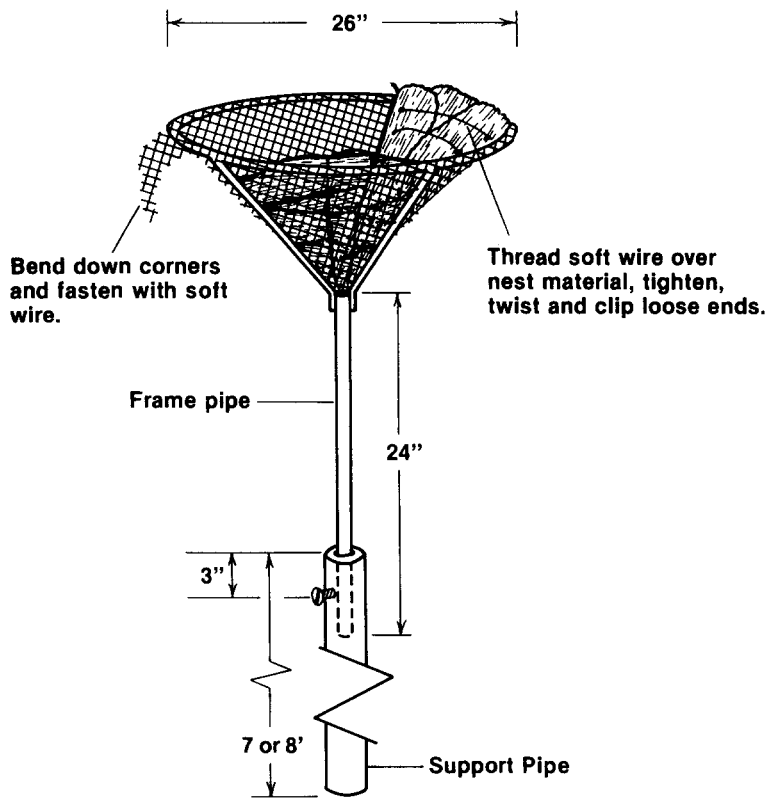

Figure 3. Wire basket structure.

Fiberglass Basket Structure

The fiberglass basket (Figure 4) is the same general dimensions as the wire basket. The assembly consists of a fiberglass basket cone; a floor flange, a 2-foot length of pipe and a 7- or 8-foot length of supporting pipe. Fiberglass basket cones are available from the following sources:

Hanson Manufacturing, Inc.
P.O. Box 536
Turtle Lake, N.D. 58575-0536

Kenco Plastics Co., Inc.
P.O. Box 39
Necedah, Wis. 54646

Pleasure Products Manufacturing Co.
2461 16th Avenue South
Moorhead, Minn. 56560

Raven Industries, Inc.
Plastics Division
Box 1007
Sioux Falls, S.D. 57101

The interior of the cone should have a roughened surface to enable the ducklings to climb to the top and leave the structure. One way to roughen this surface is to apply a mixture of small shavings and woodchips with the last coating of fiberglass.

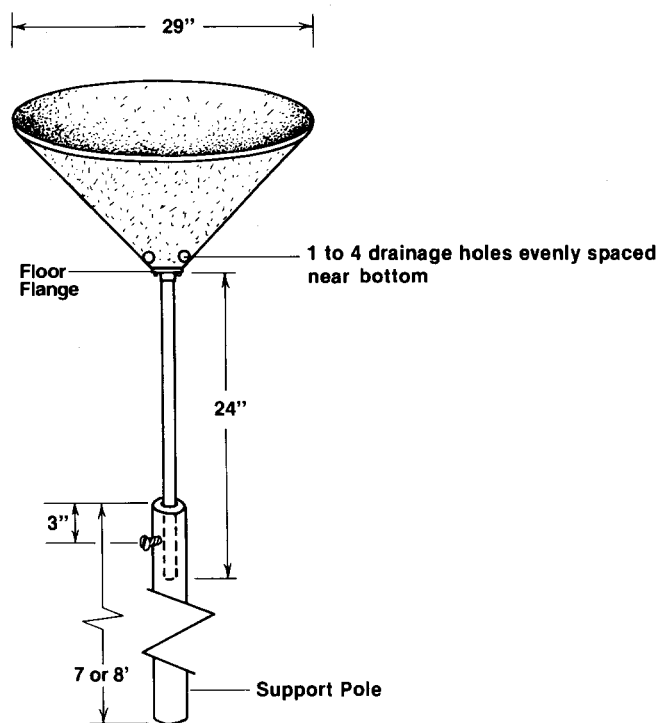

Figure 4. Fiberglass basket and support assembly.

Materials Needed

- 1 29-inch diameter x 11-inch deep fiberglass basket
- 1 7- or 8-foot length of 1½-inch I.D. pipe
- 1 2-foot length of 1-inch I.D. pipe which is threaded to screw into the floor flange (0.85/ft)
- 1-inch floor flange
- 1 3/8-inch x 1-inch N.C. capscrew

Construction

The supporting 2-foot piece of pipe is attached with an ordinary floor flange. This is done by drilling four holes in the flat base of the cone to match those in the flange and then bolting the flange in place with small bolts and washers of appropriate size. One end of the 2-foot length of pipe must be threaded so it can be screwed into the flange. The size of the flange depends on the pipe available. A satisfactory combination is a 1-inch floor flange into which is screwed on to a 2-foot length of 1-inch I.D. pipe. The 1-inch I.D. pipe telescopes into a 1½-inch I.D. support pipe which is driven into the marsh bottom. A 5/16-inch hole is drilled 2 inches from the top end of the 1½-inch I.D. support pipe and is threaded with a 3/8-inch N.C. tap and fitted with a 3/8-inch x 1-inch N.C. capscrew, as in the wire basket structure. Four 3- to 3½-inch diameter holes are drilled into the sides of the fiberglass baskets prior to their installation. This is done to permit wiring of the nest material in place and also to enable ducklings to escape if the level of nest material becomes too low, preventing the young birds from leaving the nest structure. These four holes are spaced evenly around the basket, the upper edge of the holes being 5 inches below the basket rim. In addition, one to four ½- to 1-inch diameter holes are drilled near the bottom of the cone to allow drainage (Figure 4).

An enlarged version of the basket structure has been used by giant Canada geese and mallards. This jumbo-sized structure has a basket diameter of 36 inches and it is supported by a 2-inch pipe.

In localities where both giant Canada geese and mallards are found, it may be advisable to put out the larger nesting structures which are recommended for geese. Mallards will also nest on these larger structures.

It is very likely that any of several types of basket-like structures would be acceptable to mallards. For this reason, there is much room for innovation in constructing nesting structures from excess or surplus materials, thereby reducing the costs.

Nest Material

After the basket and frame are assembled, the inside must be lined with nesting material. Flax straw is the best nesting material since it holds together

well and resists being blown from the structure by wind. The flax straw should be soft and fluffy with the fine fibers clinging together, providing a texture resembling cotton or wool. Coarse, unbroken stems of flax straw should not be used. The coarse stems can be softened by running them through a combine straw chopper a second time, or by using other farm equipment vehicle gives the desired consistency. If such equipment isn't available, the straw can be softened manually by kneading it repeatedly by hand until the desired consistency is obtained. Native hay, small grain straw or marsh vegetation can also be used for nesting material but they are less desirable than flax straw. Alfalfa hay crumbles too easily and is quickly blown away, so it should never be used as nesting material (Figure 5).



Figure 5. Flax straw is the best nesting material since it holds together well and resists being blown from the structure by wind.

The nest material is installed by packing loose straw or hay into the lower half of the basket (Figure 6). Above this is placed a circle of straw or hay which extends slightly above the level of the rim of the basket. This doughnut shaped arrangement of nesting material is secured in place on four sides of the basket with light wire (Figure 2). The wires are threaded from the outside into the hardware cloth in the side of the basket, up through the nest material and over the rim of the basket. These wires should not cross the center cavity where the eggs will be deposited. The center cavity should be about 4 inches deep. If necessary, additional loose nest material should be pressed into the center to provide this depth (Figure 6).

For fiberglass baskets, wires are threaded from each of the four escape holes into and up through

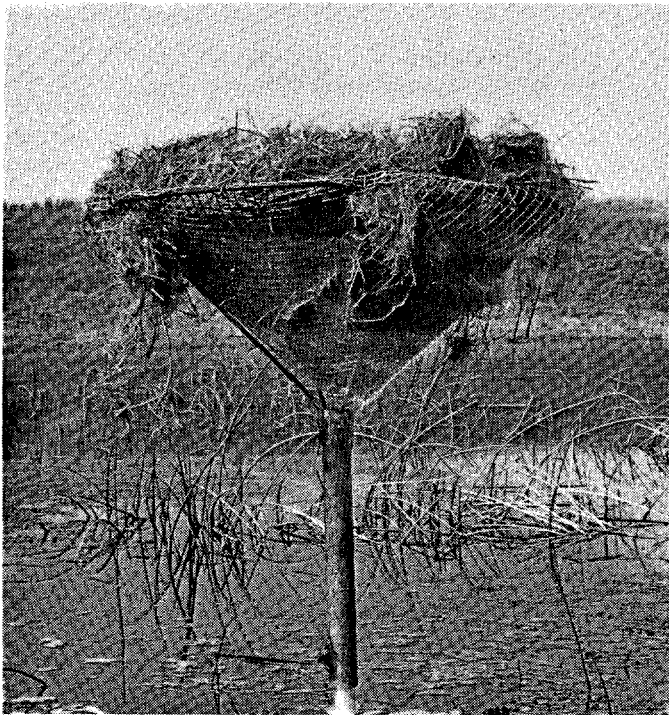

Figure 6. Pictured above is a wire basket properly filled with flax straw nest material. All nest structures must have suitable nesting material installed annually.

the edge of the doughnut shaped circle of nesting material and over the rim of the basket. The wires are then pulled together, twisted, and the ends clipped off.

Placement (Wires and Fiberglass Structures)

It has been speculated that a reason why mallards take to the elevated structures so readily is that from the air the circular structures may resemble a muskrat house or hummock in the marsh. Open water at the edge of cattails, bulrushes or other emergent cover, or small patches of open water in stands by such cover provide good placement sites. The nearby emergent marsh plants will help protect the structures from ice, wind and water action (Figure 7).

The support pipe should be driven into at least 1 foot of solid earth in the marsh bottom. Place the structures where they will not be exposed to excessive ice and wave action during the spring breakup. Late fall or early winter is the best time to drive the support pipes into the marsh bottom. After the ice is thick enough to support a person, it is relatively easy to pick up suitable locations and drive the pipe. An ordinary steel post driver is satisfactory for installing the pipe after a hole has been made in the ice. At this time, the marsh bottom will be unfrozen, and it will be easier to determine whether the pipe is firmly anchored so it will stay in place. If the ice is thick, a power driven ice auger of the kind used by winter fishermen can simplify the task. Some augers have a special attachment for the blade which enables it to cut into the solid earth of a marsh bottom. The nest structure need not be attached at the time the support pipe is driven, but it is desirable to do this before the ice breaks up in the spring. Support pipes may also be driven in during other seasons by standing in the water or working from a boat.

When in place, the bottom of the basket should be at least 30 inches above the water level, but heights of 36 to 48 inches above water are recommended. Ordinarily, water depths of from 1 to 3 feet are satisfactory for installing the structures. The possibility of

The basket top should be as high as nearby plants, and at least 3½' above the water

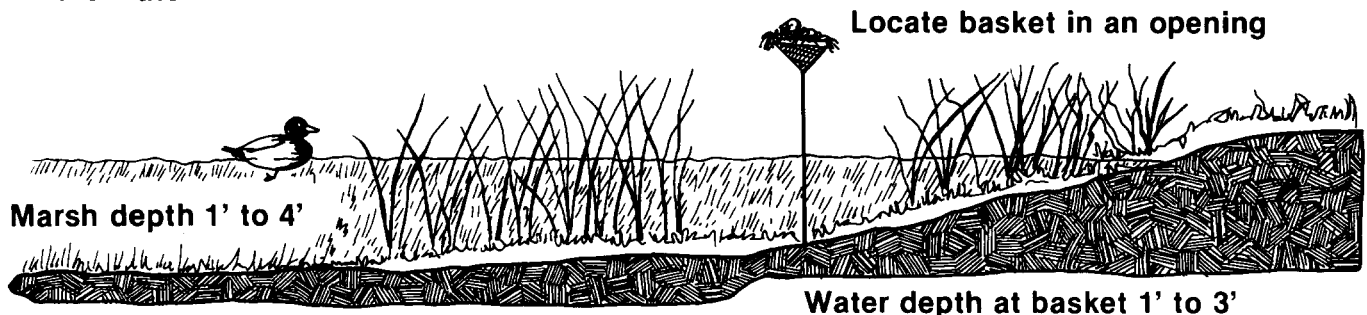

Figure 7. Open water at the edge of cattails, bulrushes or other emergent cover, or small patches of open water in stands of such cover provided good placement sites.

changing water levels should be considered and structures should not be placed in situations where the level is likely to rise to less than 18 inches from the base of the basket. It is recommended that structures be placed on ponds that hold water at least through mid-summer. Ice, wind, or wave action may cause some structures to tilt or fall after the first year. This fault may be corrected by moving the baskets to sites which are more protected or have firmer bottoms, or by driving the support pipes deeper.

A rule of thumb is to situate the structures as far from shore as possible, staying within adjacent emergent cover types and range of water depths. Another rule of thumb is to avoid placing large numbers of structures in a marsh. A single structure may be sufficient for a small pond or pothole. However, four to six may be placed in a marsh 25 acres in size or larger by spacing them as far apart as possible. If these structures are used by nesting hens, more can then be added.

Maintenance (Wire and Fiberglass Structures)

It is very important to properly install and maintain the structures to prevent predation by raccoons. A raccoon will climb a rusty support pipe or one that is not smooth. The pipe should be maintained in an upright position, for if it starts to lean, a raccoon may be able to climb into the basket. Nesting baskets should be inspected and serviced annually, preferably before April 1. Fresh nesting material should be installed annually and all retaining wires checked and replaced as needed (Figure 8). While flax straw is the best nesting material, it has to be replaced annually. The basket life will be extended if the assembly is removed from the support pipe after each nesting season and is repaired and serviced prior to being replaced again before the beginning of the next nesting season.

Structures that consistently receive no use may be moved to new locations where they may be more acceptable to female mallards.

Both wire and fiberglass baskets will stand in place and otherwise hold up in usable conditions for many years. Many have stayed in place for 12 to 15 years.

When installing or servicing baskets in winter, the nest material can be secured in place in a shop or warm indoor situation. Then the completed basket assemblies are taken to the field and mounted on support pipes which are already in place. This procedure may involve removing the baskets, servicing them, and returning them to the field, but in periods of very cold weather it may be worth the added time and effort.



Figure 8. Nesting baskets should be inspected and serviced annually, preferably prior to April 1.

When servicing the basket during the winter by driving on ice, avoid leaving trails that lead directly to the basket. Vehicle trails through emergent cover make excellent predator lanes. If using a vehicle, it is better to enter the pond from the shore opposite the basket.

Hawks and owls may occasionally perch on or nest in these elevated nesting structures. Usually the incidence of this type of use is quite low and is not great cause for concern.

CONCLUSION

Although mallards readily use homemade nest sites, such sites are no substitute for good waterfowl habitat. Wetland complexes with adjacent tall, dense, undisturbed blocks of nesting cover are still essential to maintaining a diverse waterfowl population.

Many waterfowl species have not demonstrated the adaptability of the mallard in the use of homemade nest sites. Thus their survival, as well as that of the mallard, still hinges on the availability of many kinds of waterfowl habitat.

REFERENCE AND ADDITIONAL READING

- Bellrose, F.C. 1976. Ducks, geese and swans of North America. 2nd ed. Stackpole Books, Harrisburg, PA. 543 pp.
- Doty, H.A., F.B. Lee and A.D. Kruse. 1975. Use of elevated nest baskets by ducks. Wildlife Society Bulletin. 3:68-73.
- Henderson, C.L. 1985. Woodworking for Wildlife. Minnesota Department of Natural Resources. Nongame Wildlife Program. 48 pp.
- Johnsgard, P.A. 1975. Waterfowl of North America. Indiana University Press, Bloomington. 575 pp.
- Lee, F.B. 1982. Homemade Nesting sites for Mallards. North Dakota Outdoors, 44 (9):6-9.
- Lee, F.B., C.H. Schroeder, T.L. Kuck, L.J. Schoonover, M.A. Johnson, H.K. Nelson, and C.A. Beauduy. 1984. Rearing and Restoring Giant Canada Geese in the Dakotas. North Dakota Game and Fish Department, Bismarck. 79 pp.
- Messmer, T.A., M.A. Johnson, and F.B. Lee. 1988. Homemade Nest Sites for Giant Canada Geese. NDSU Extension Service, Fargo, N.D. Circular WL910. 16 pp.
- Sidle, J.G. and P.M. Arnold. 1982. Notes on Duck Nest Structures. Prairie Naturalist, 14(2):59-60.
- Stewart, R.E. 1975. Breeding Birds of North Dakota. Tri-College Center for Environmental Studies. Fargo, N.D. 295 pp.

Helping You Put Knowledge To Work

NDSU Extension Service, North Dakota State University of Agriculture and Applied Science, and U.S. Department of Agriculture cooperating. William H. Pietsch, Director, Fargo, North Dakota. Distributed in furtherance of the Acts of Congress of May 8 and June 30, 1914. We offer our programs and facilities to all persons regardless of race, color, sex, religion, age, national origin, or handicap; and are an equal opportunity employer.