



Accommodating Private Development & Public Good

ARCHITECTURALMEDIATION

SARAHLOCKWOOD

 **Starting Point [Revitalization]**

Site Information

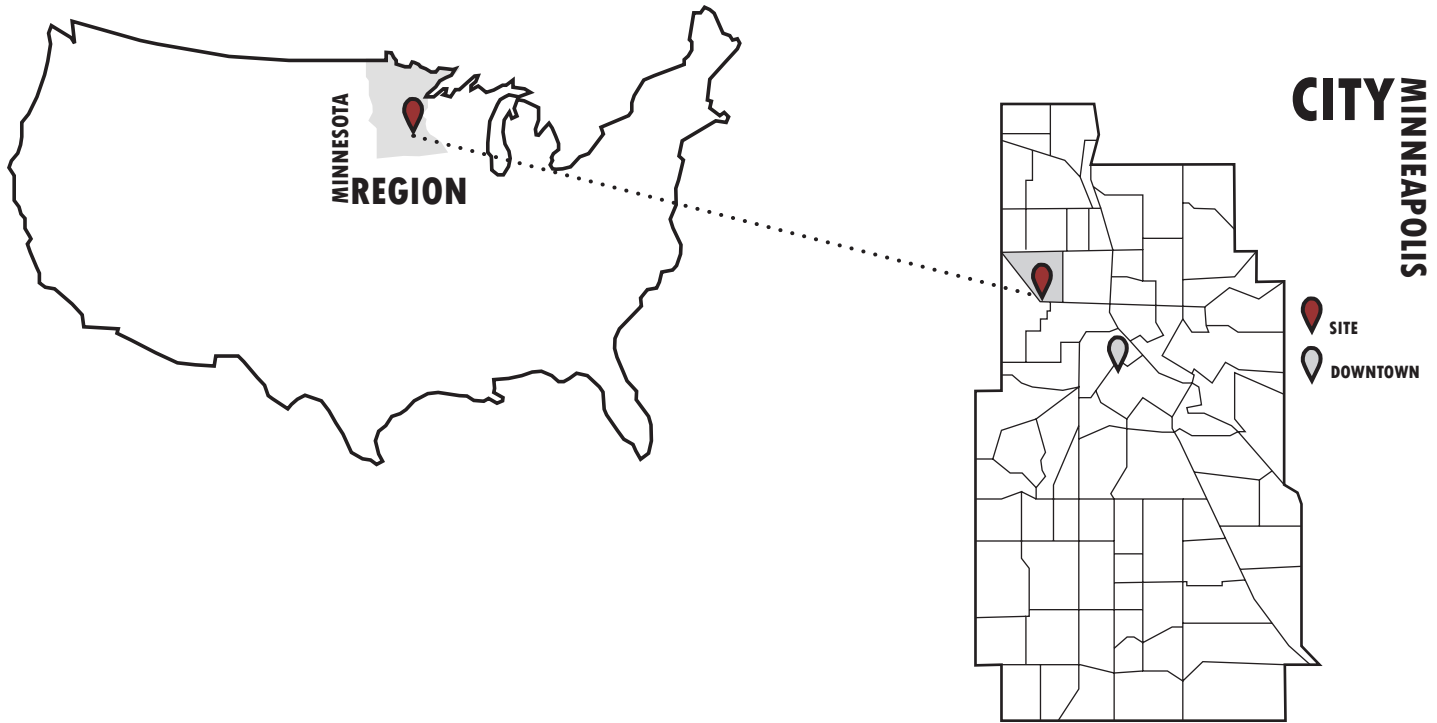

Site Information

2220 WEST BROADWAY
MINNEAPOLIS, MN



Site Information

1/2 MILE RADIUS FROM SITE



-  **SITE**
-  **THEODOREWIRTH
PARK**
-  **WESTBROADWAY
BUSINESSDISTRICT**
-  **RESIDENTIAL**



Site Information [History]



West Broadway was originally established by merchants, skilled trades-people and educators. It was the business district and cultural district of North Minneapolis.



The state's largest population of Jewish residents lived in North Minneapolis at the time of its establishment.



World War 2 - Transition to the Suburbs



Separation from employment opportunities and the lack of public resources led to deep set poverty for many residents who remained. And in the years to come this area grew to have one of the largest percentages of people living in poverty in the state.



Poverty in the area has increased the amount of crime.









For North Minneapolis the question now is - which needs to come first, "Economic Development or Public Safety.



Site Information [Numbers]

Statistics from the U.S. Census

-  Approximately 80 percent are people of color;
-  More than 25 percent speak a language other than English in the home
-  About 40 percent are under age 18
-  More than 51 percent of families with children are headed by a single parent—mostly mothers
-  Nearly 30 percent of the adult population has less than a high school education
-  Almost 60 percent of households have incomes below 200 percent of the federal poverty guideline;
-  Nearly 9 percent are unemployed.

Opportunities for Change



Opportunities for Change

North Minneapolis Organizations:

Approximately **110** licensed public and private childcare providers of varying size and capacity serve the Northside.

In North Minneapolis, **178** nonprofits provide services focused on education, health, economic development, children and family services, and others. There are 44 faith-based communities (churches, mosques, temples, etc.) on the Northside.

Source: NorthWay Community Trust



The Minneapolis Northside Arts Leadership Group



NorthPoint Health & Wellness Center
1315 Penn Avenue North
Minneapolis, MN 55411
612.302.4600
www.northpointhealth.org



Funded in part by:
NorthWay Community Trust
1501 Broadway Avenue North
Minneapolis, MN 55411
612.521.4500
www.northwaycom.org



Revitalization [What's Needed?]

Economic Development & Public Resources



Problem Statement

How can architecture mediate the interests
of private development and public good?



Premise

This thesis will explore how a building can be used to mediate the needs of both private development and public resources within the same building, aiming for the result of economic growth and better quality of life for urban communities undergoing revitalization. By combining public space and private space within one site this thesis can develop strategies to mediate the needs and interaction between the realms of private and public.



Public/Private

“Major public sector investment in enhancing the quality of the public realm will be a pre-cursor to building confidence in the private sector and the development of the city’s tourism economy and to the attraction of private sector investment in property development activity.”

- Ali Madanipour (Public and Private Spaces of the City)

Public/Private [Importance of Boundaries]

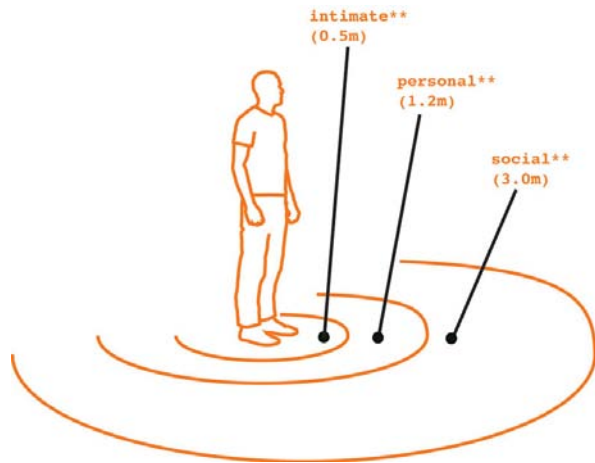

“The boundaries that separate the two realms are the most visible manifestation of this division of social life. Architectural and geographical articulation of the boundary is thus the embodiment of a divide, the signifiers of social organization.”

- Ali Madanipour (Public and Private Spaces of the City)

Opportunities for Change



Typology [Transit - Retail - Arts]

· · · · EFFECTS OF SPACE TYPES ON THE COMMUNITY · · · ·



COFFEESHOP/RETAIL

- **Neighborhood residents currently feel the need for more businesses to serve the area.**



GALLERY

- **The arts creates a unique identity for the area, this makes it a destination and brings more pedestrians to the site.**
- **Studios provide space for youth, and public arts can create a sense of belonging within the community.**



TRANSIT

- **Gateway into the community**
- **Gathering Space for residents**
- **Way for residents to access jobs**
- **Economic growth at transit stop**

Typology [Transit]



LIGHT-RAIL

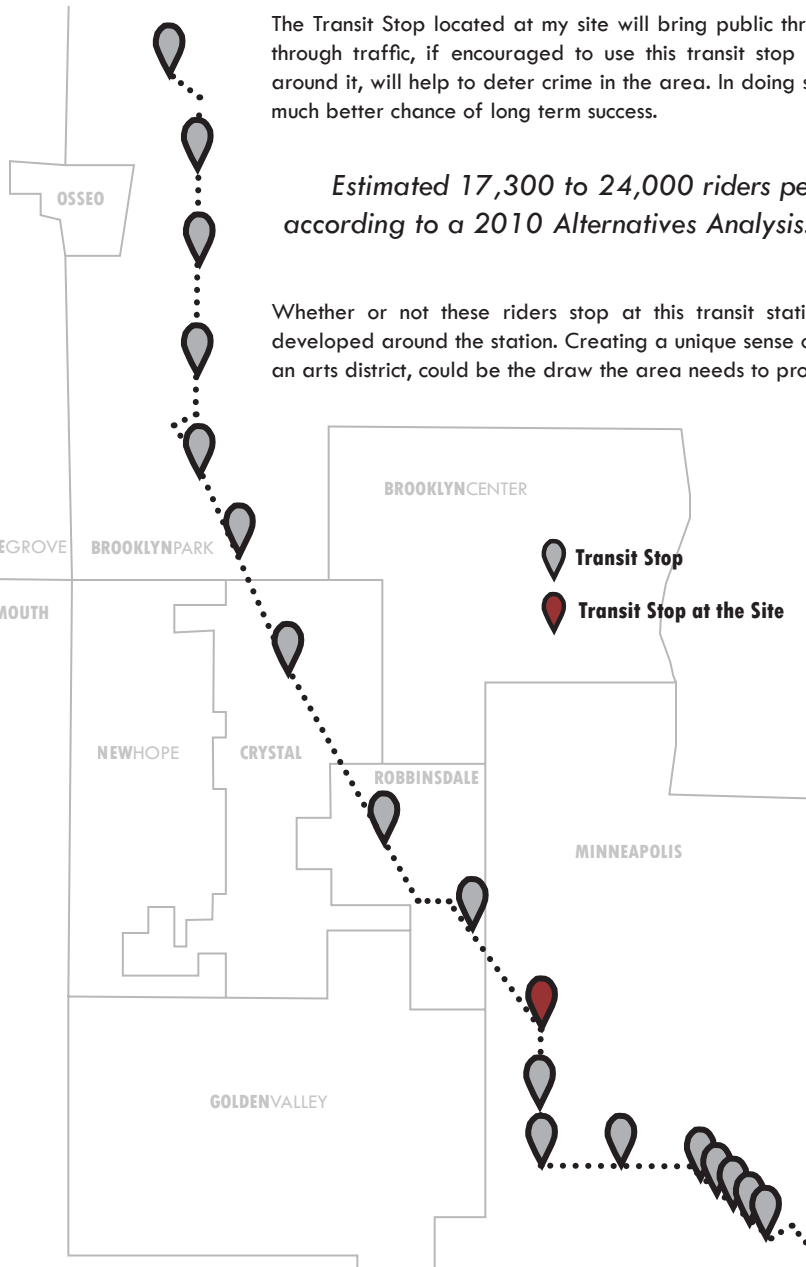

The Transit Stop located at my site will bring public through the community. This through traffic, if encouraged to use this transit stop and explore the spaces around it, will help to deter crime in the area. In doing so, businesses will have a much better chance of long term success.

Estimated 17,300 to 24,000 riders per day by 2030 according to a 2010 Alternatives Analysis. (Hennipen, 2012)

Whether or not these riders stop at this transit station depends on what is developed around the station. Creating a unique sense of identity, specifically as an arts district, could be the draw the area needs to provide **economic growth**.

Households without vehicles:
North Minneapolis: 22%,
Minneapolis: 20%,
Hennepin County: 11%



Typology [Retail]

The public has identified additional need for bookstores, discount retailers, bakeries, sit-down restaurants, sporting goods, music stores, theaters, workout/health centers, specialty clothing stores, cafes, and building materials/garden stores.

- Northside Community Listening Project

Typology [Arts]



Site Analysis [Traffic & Movement]

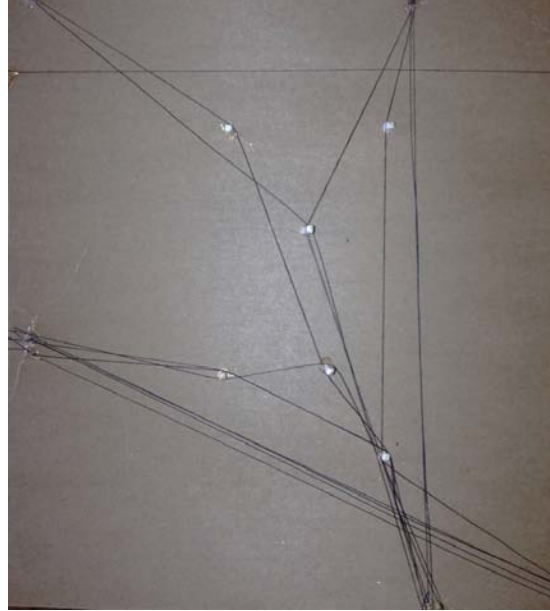
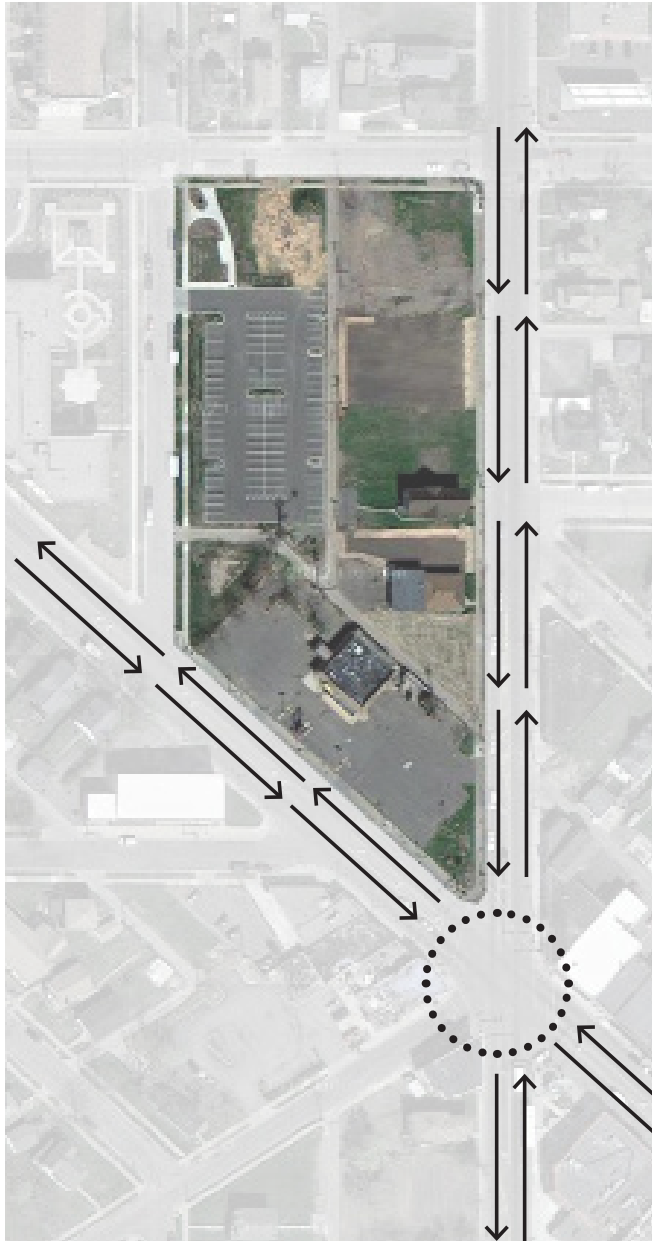

Site Views

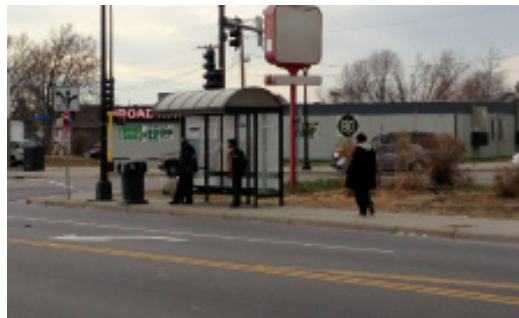
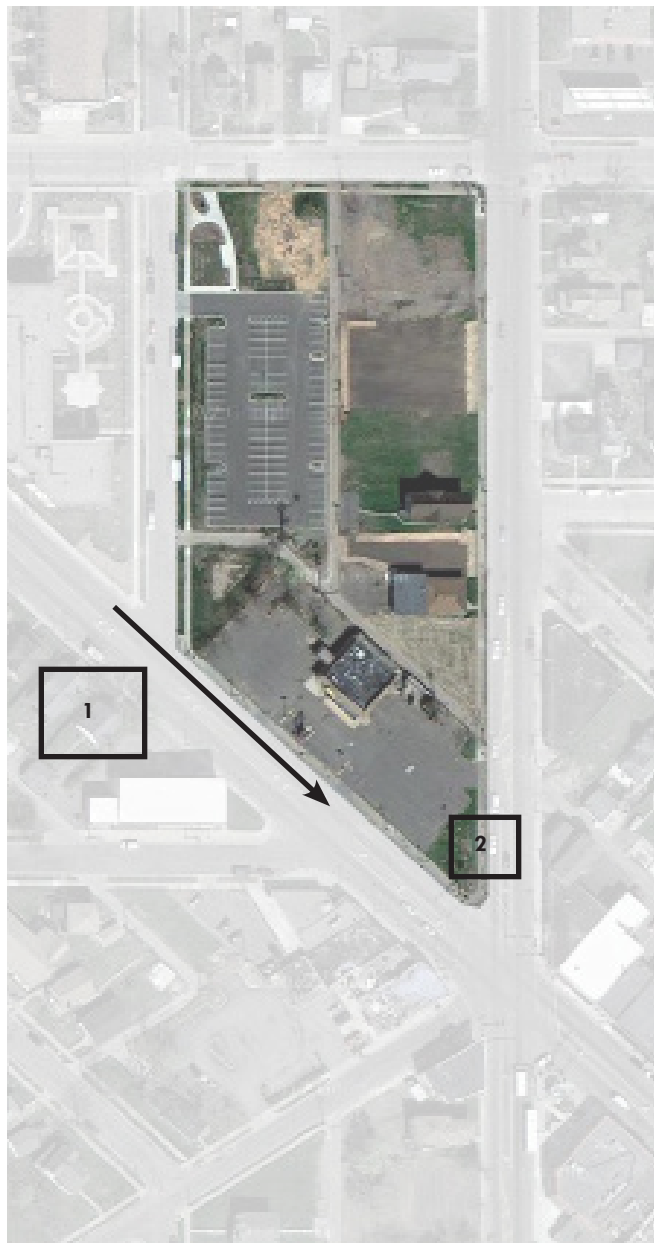

Site Views



1 THE CHURCH OF ST ANNE-ST JOSEPH HIEN



2 ST ANNE SENIOR COMMUNITY



3



4



Design Phase

 **Process**

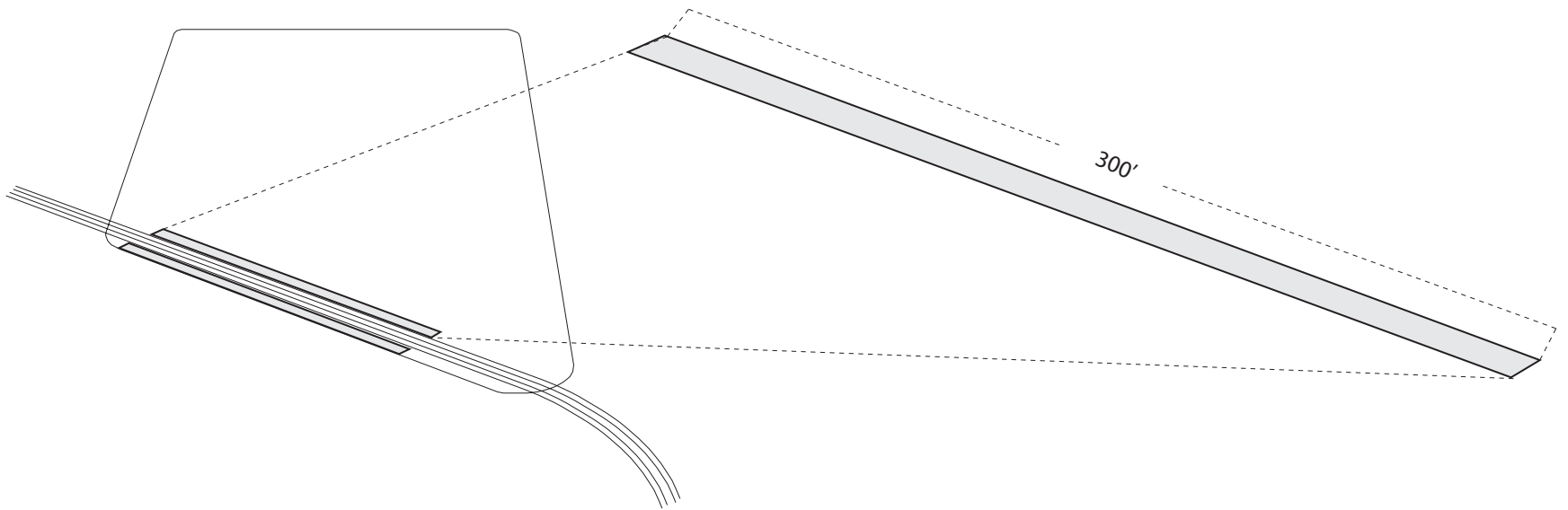

Process

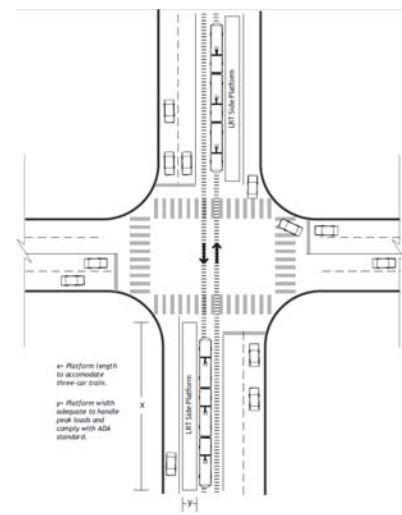
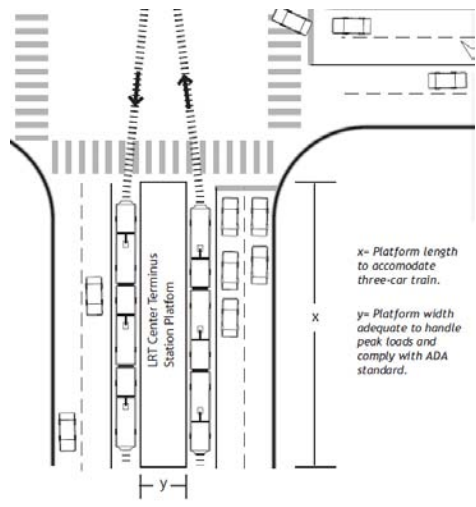

Figure 12 Single Track Platform Configuration

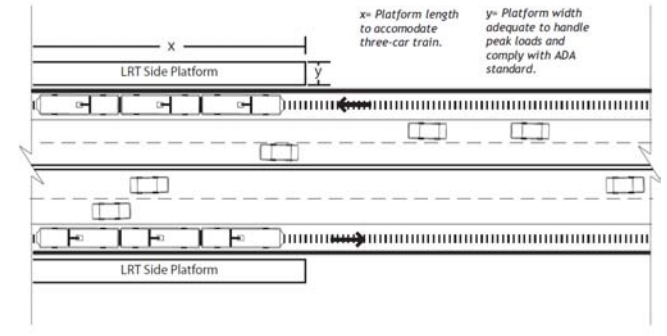
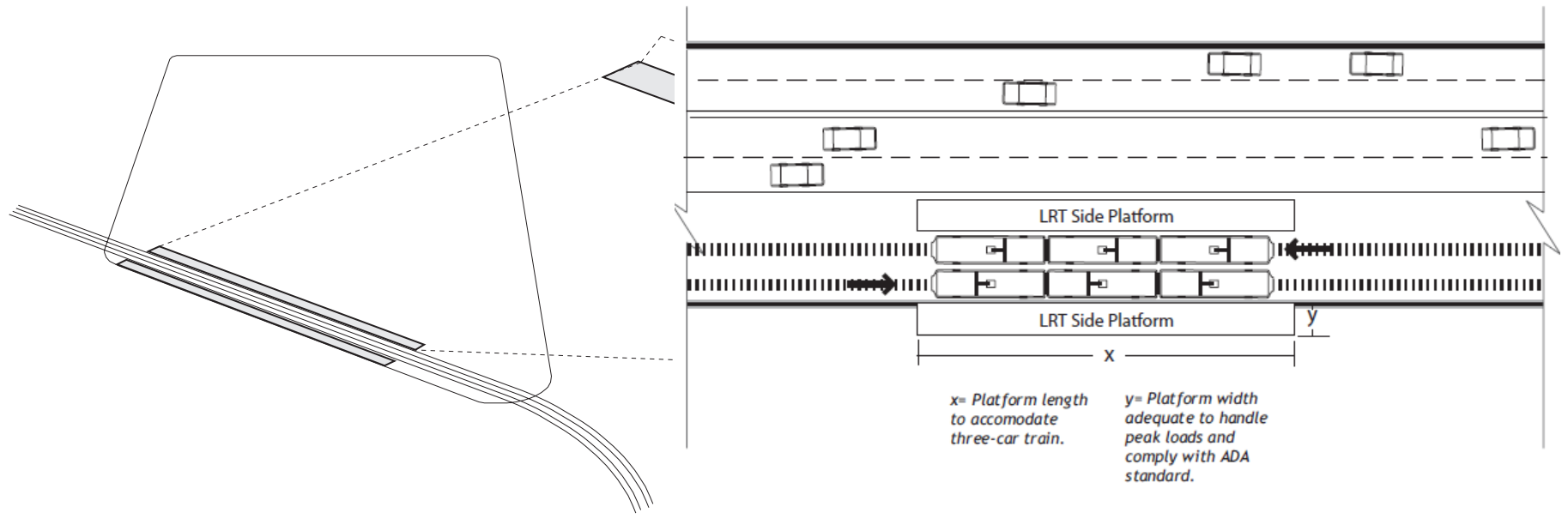
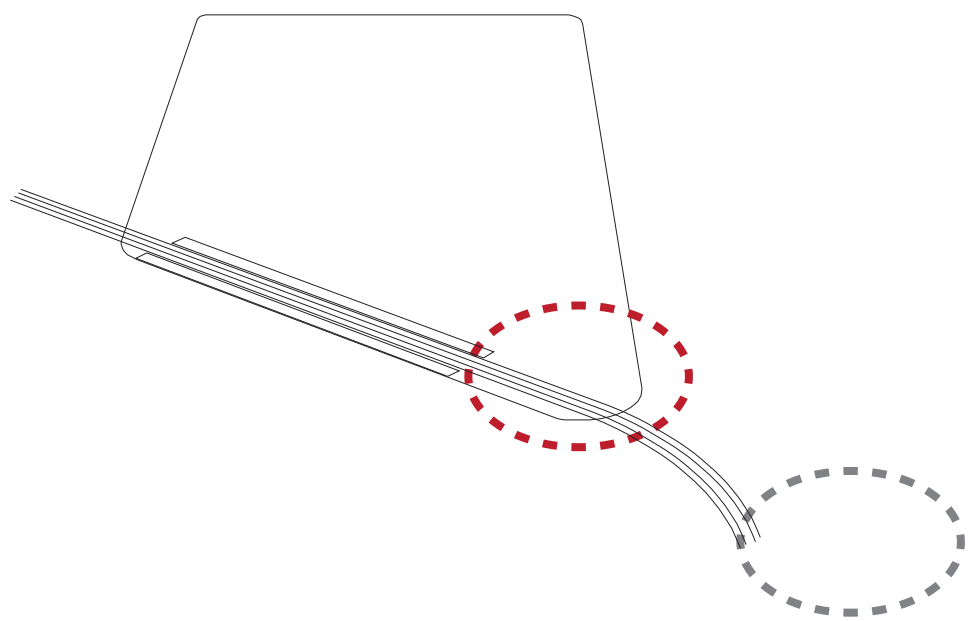

Figure 10 Parallel Streetside Platform Configuration



Process [Public Plaza]



West Broadway Events [Farmers Market]



OPENED 2011

MISSION

The West Broadway Farmers Market increases healthy food access, promotes economic development among Northsiders, and cultivates a dynamic gathering space for community members, visitors, and businesses.

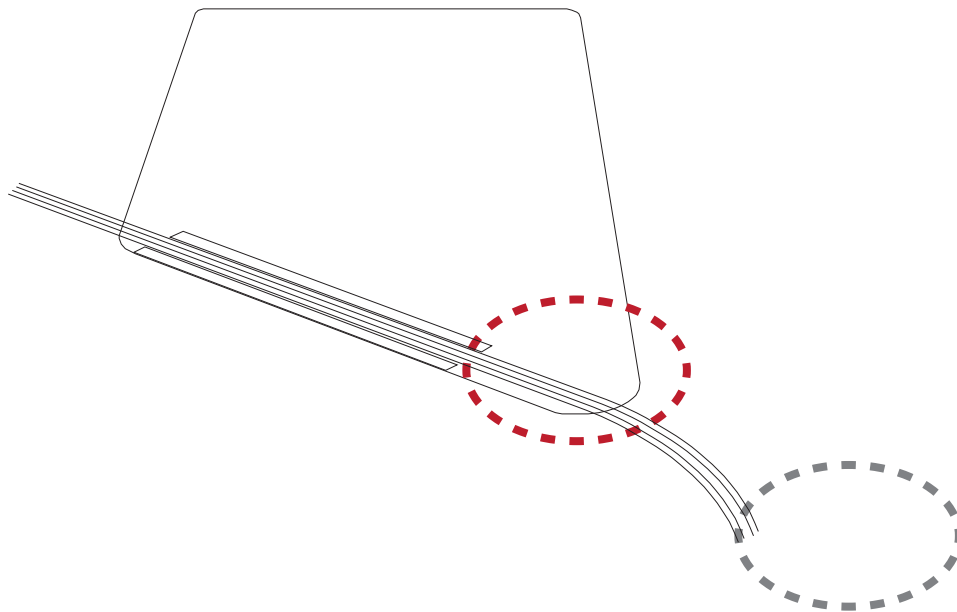

West Broadway Events [Art Flow]

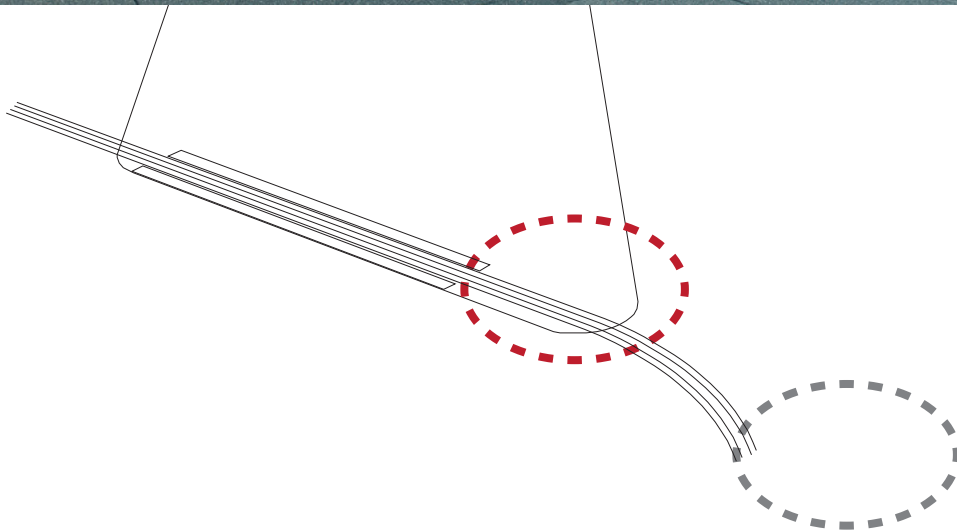

West Broadway Events [Day of Dignity]

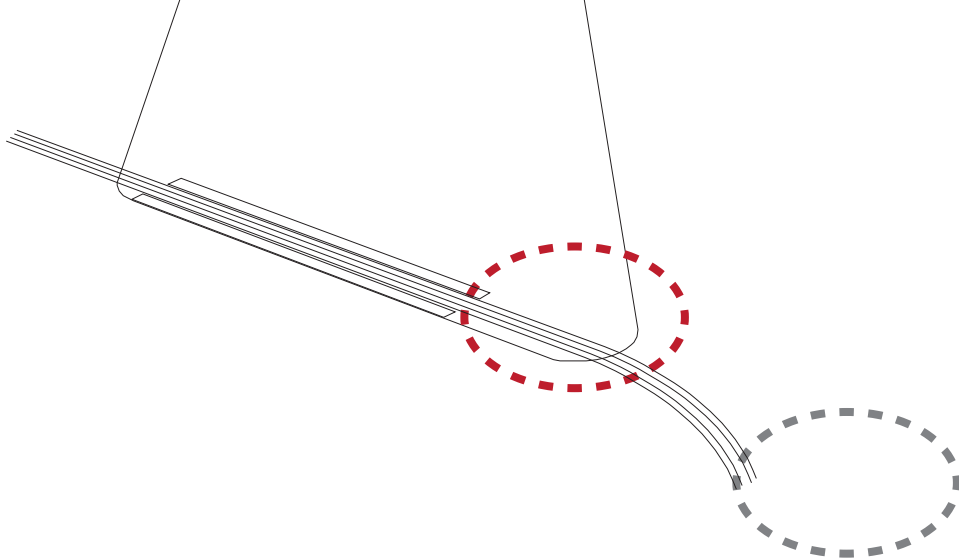

Process [Transit]

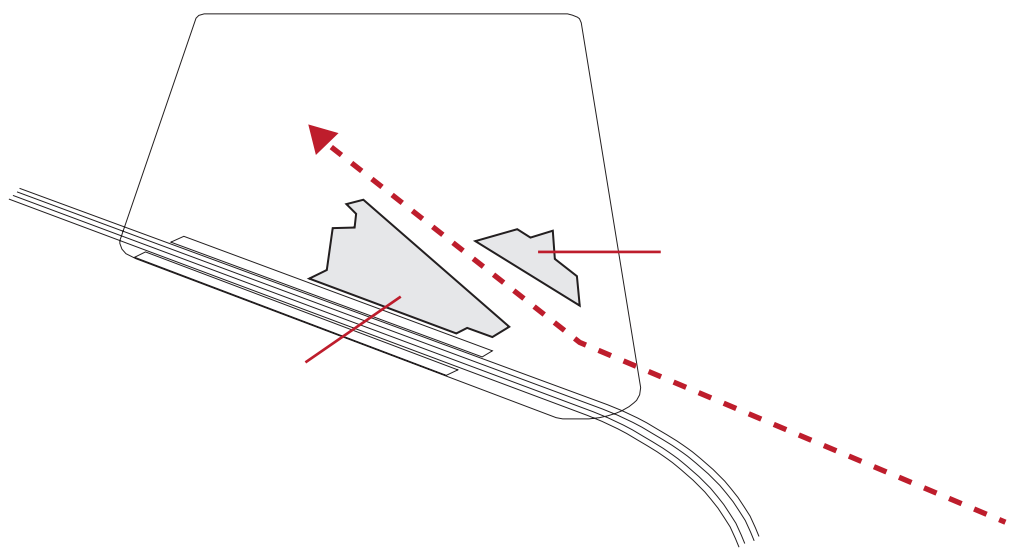

 **Process [Arts]**

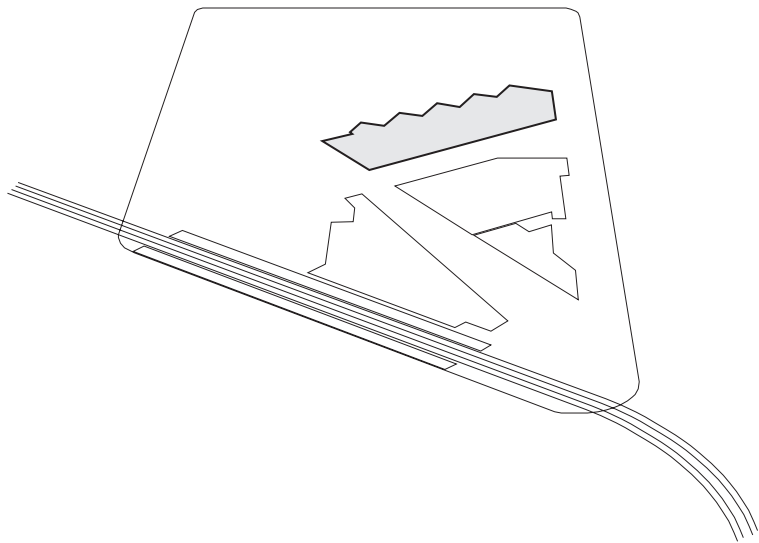

Process [Studio Space]

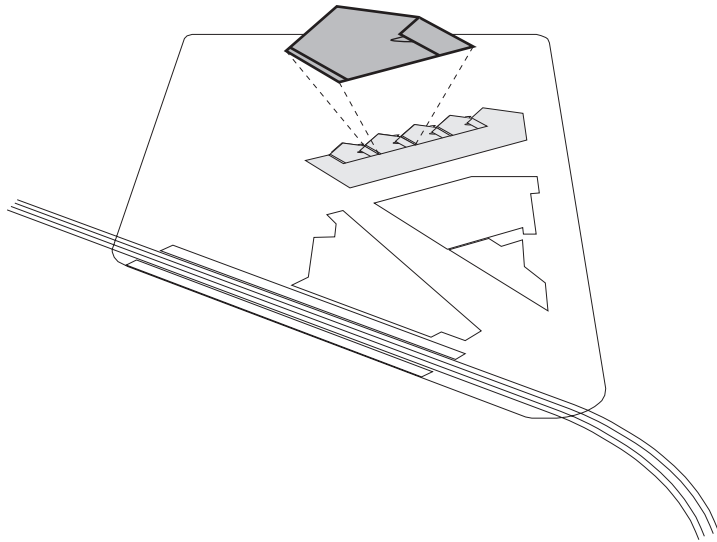

First Floor Plan

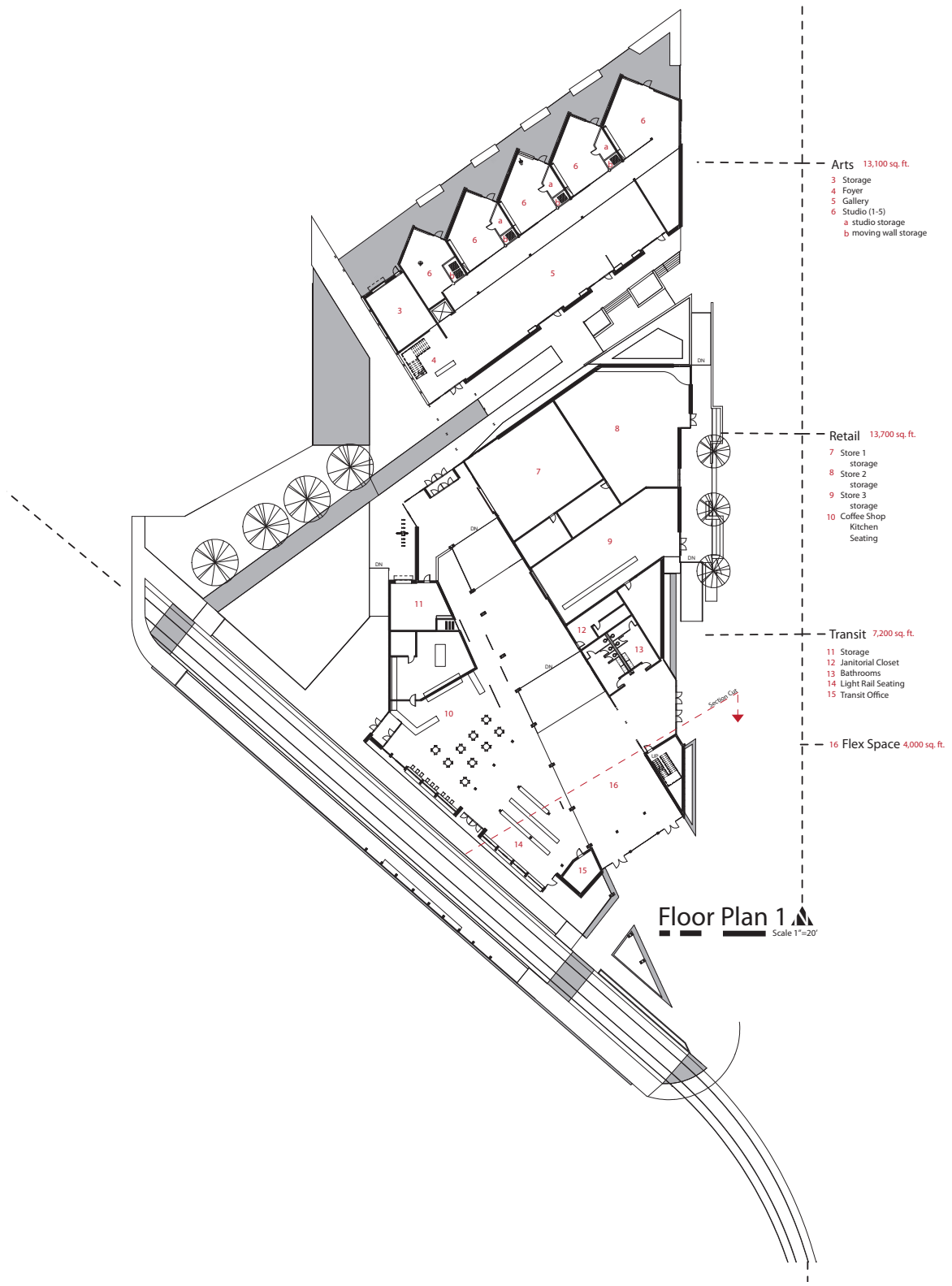

Floor Plan 1
Scale 1"=20'

Flexible Space

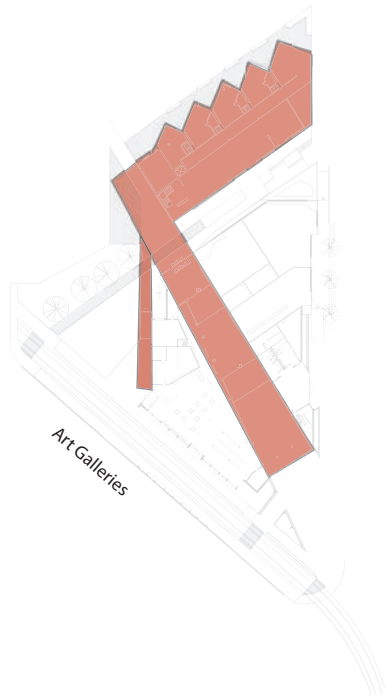

Second Floor Plan

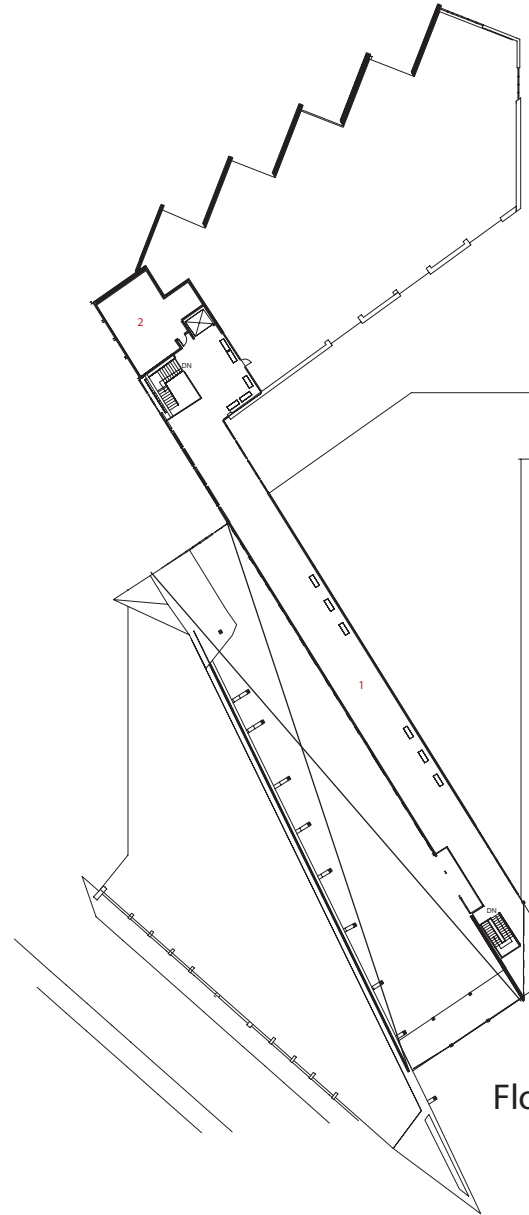

- 1 — Arts 5,200 sq. ft.
Gallery
- 2 — Mechanical
900 sq. ft.

Floor Plan 2



Site Plan

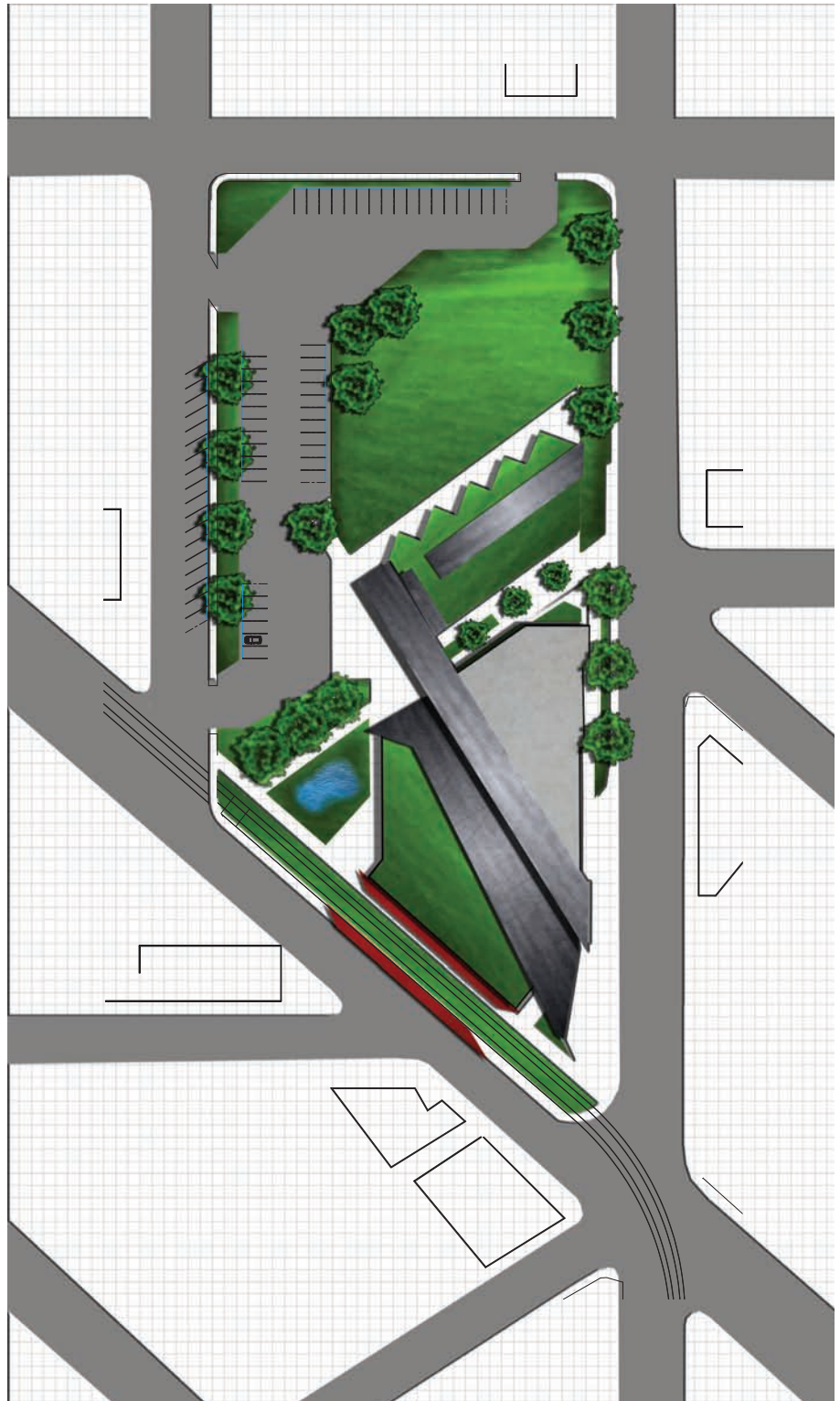

Mediating Public/Private [Community]

View from West Broadway

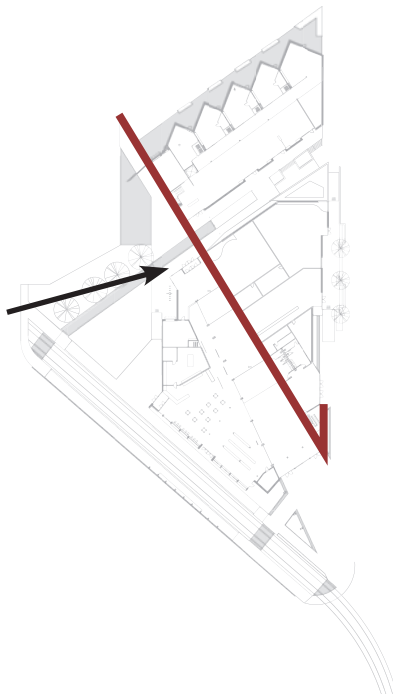

Mediating Public/Private [Community]

View from Penn Ave

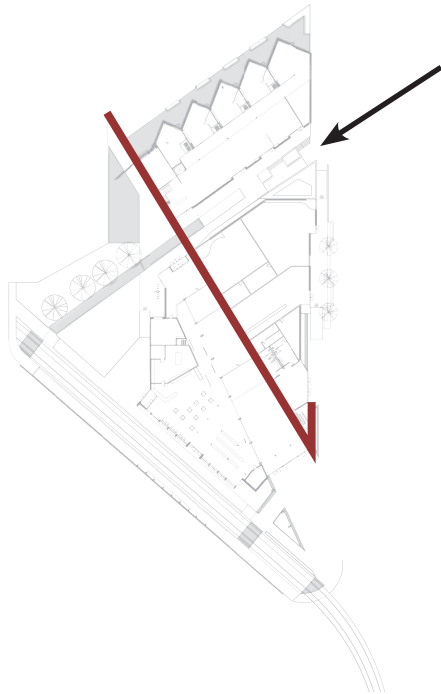

Resolving Corners

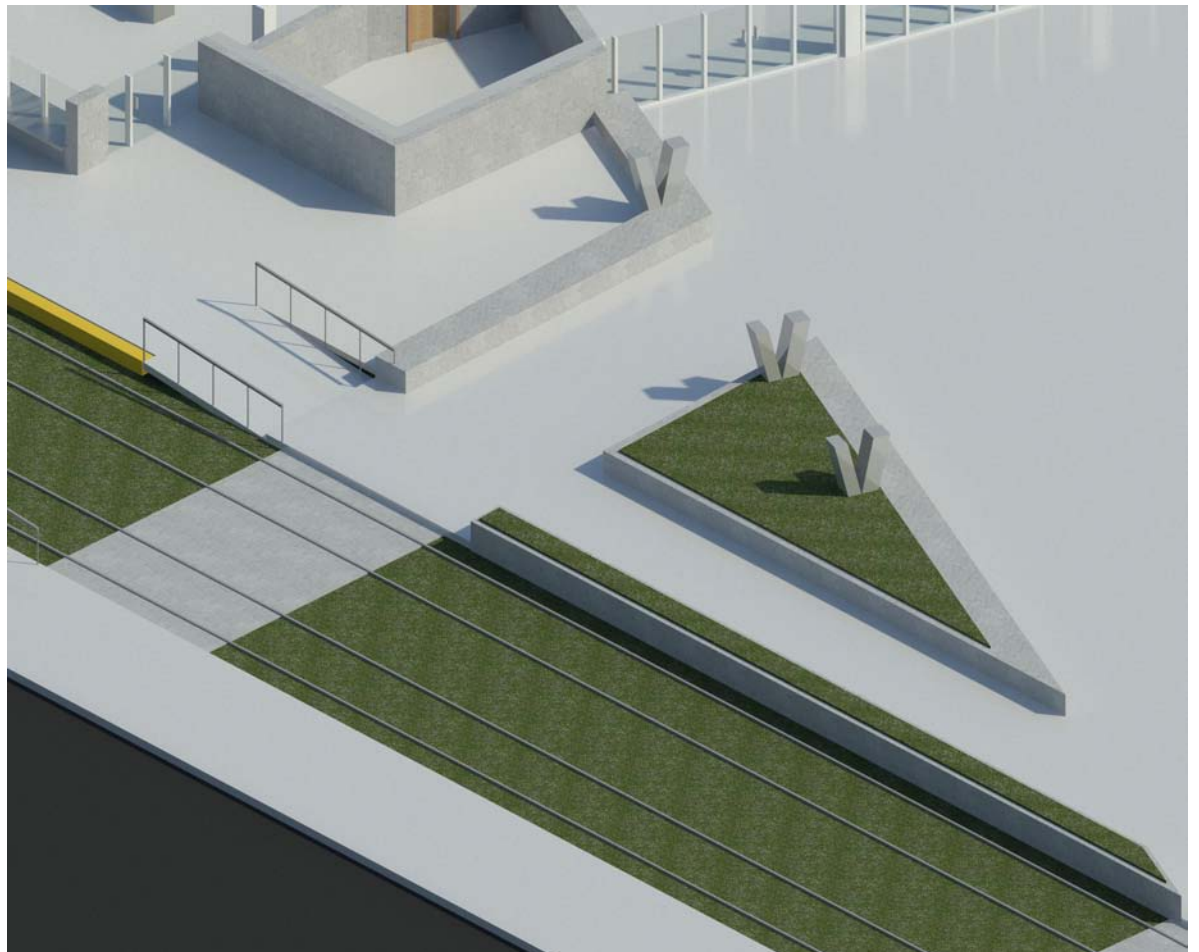
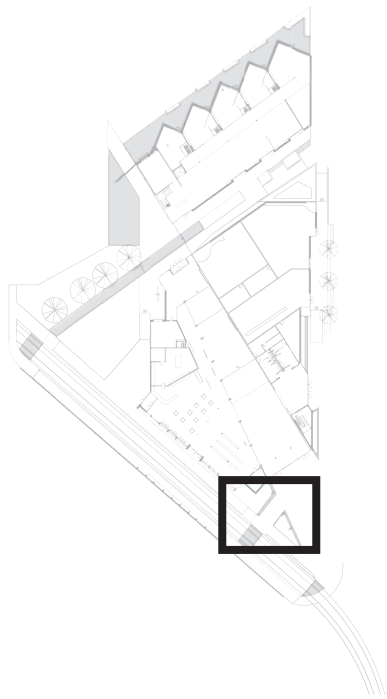

Resolving Corners

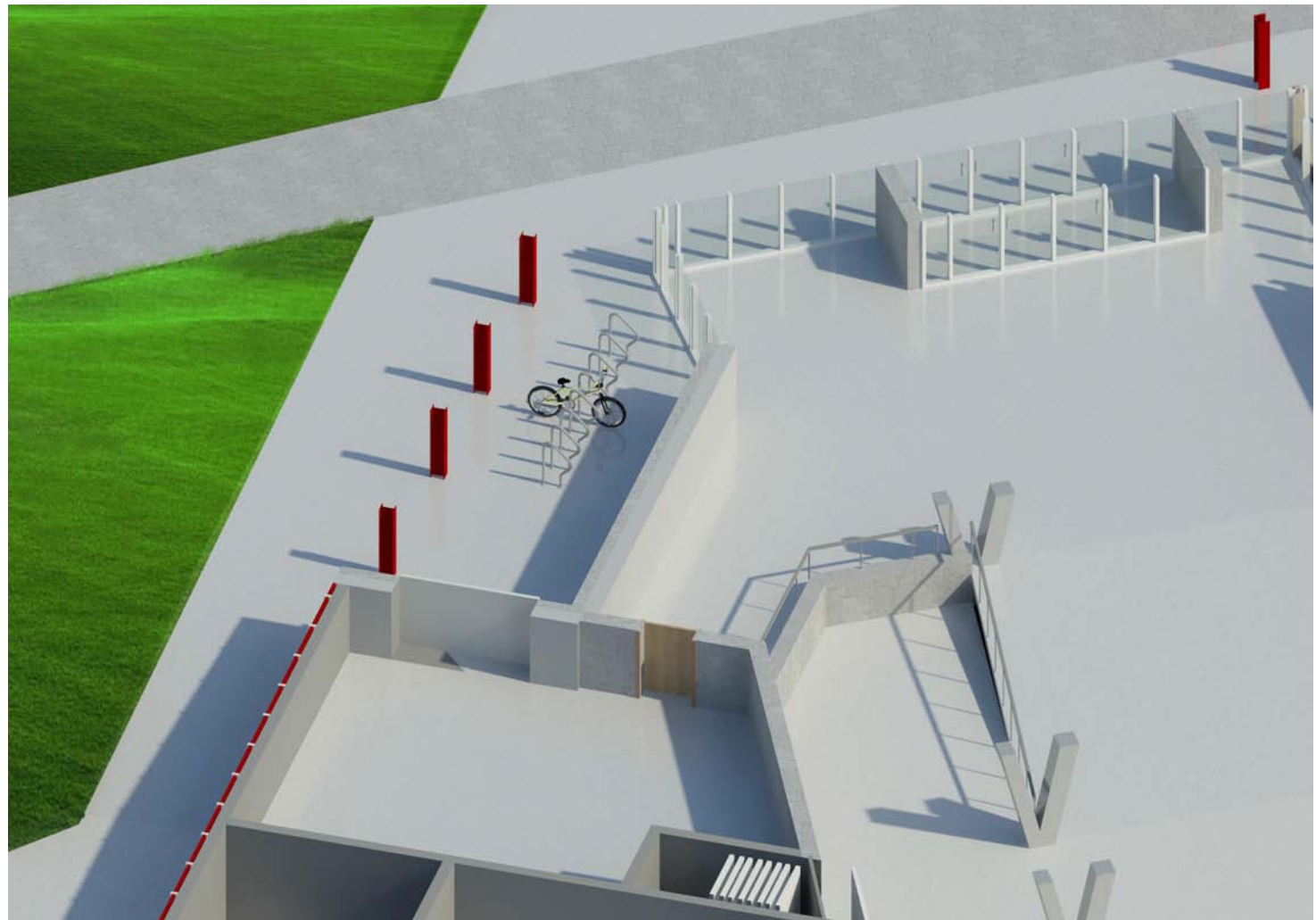
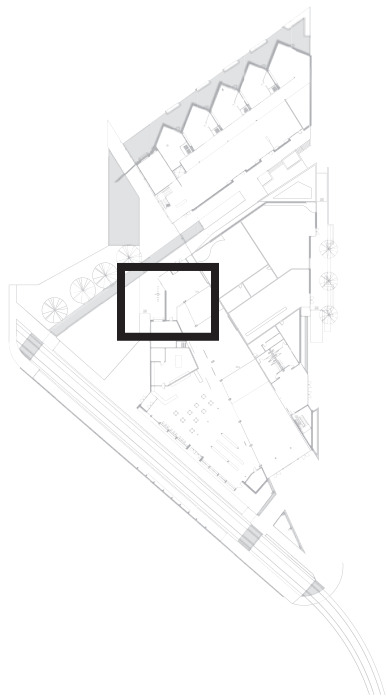

Resolving Corners

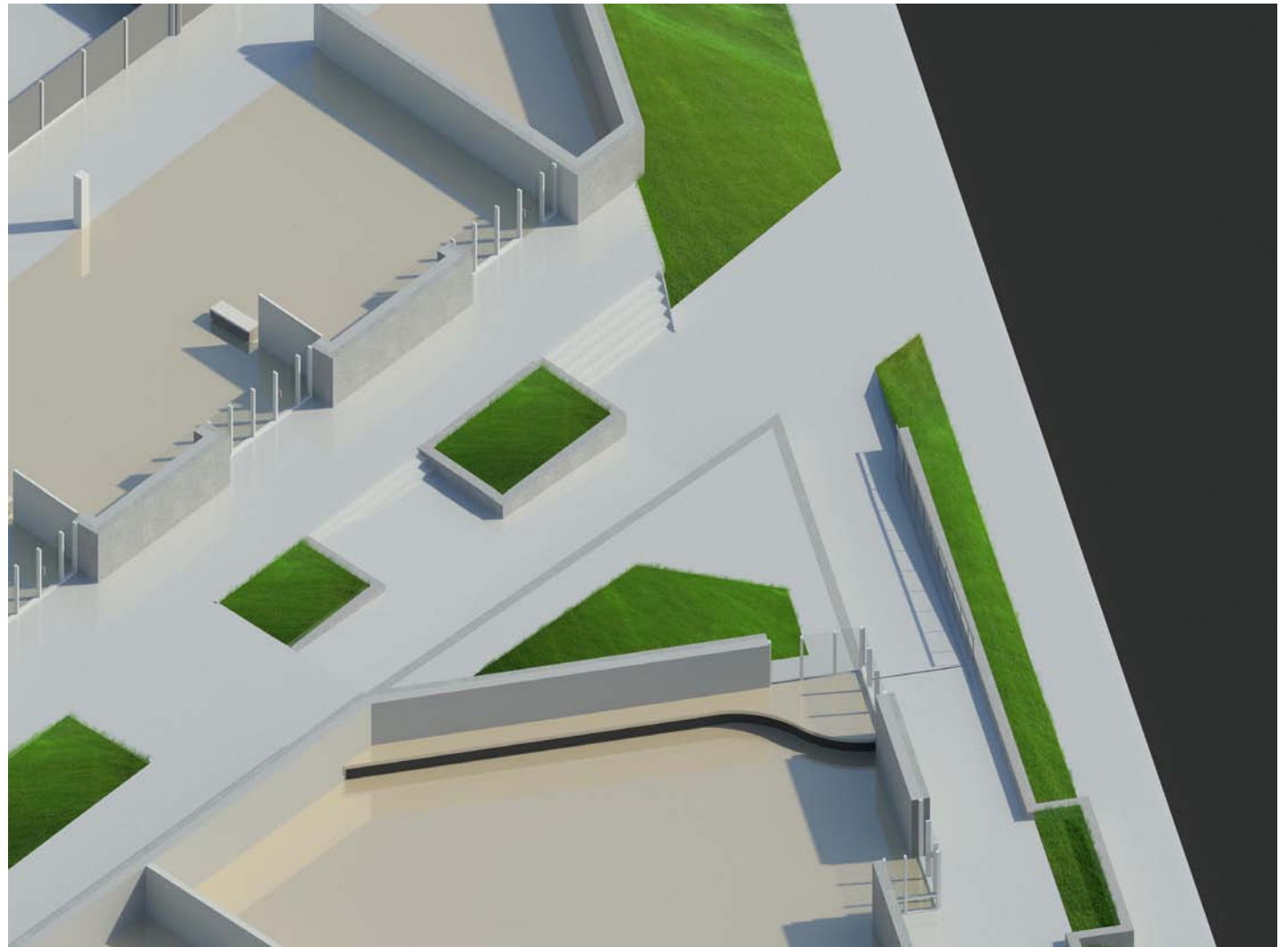
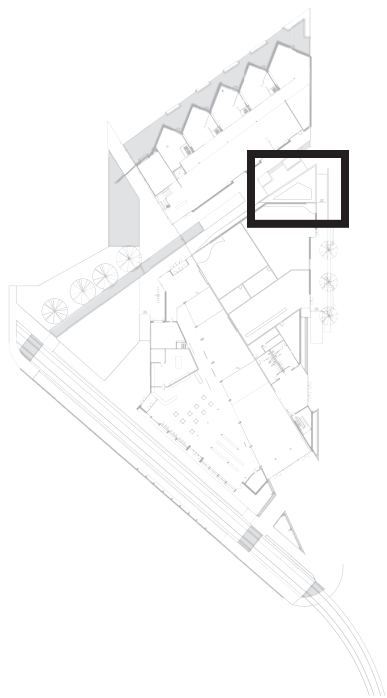

Resolving Corners

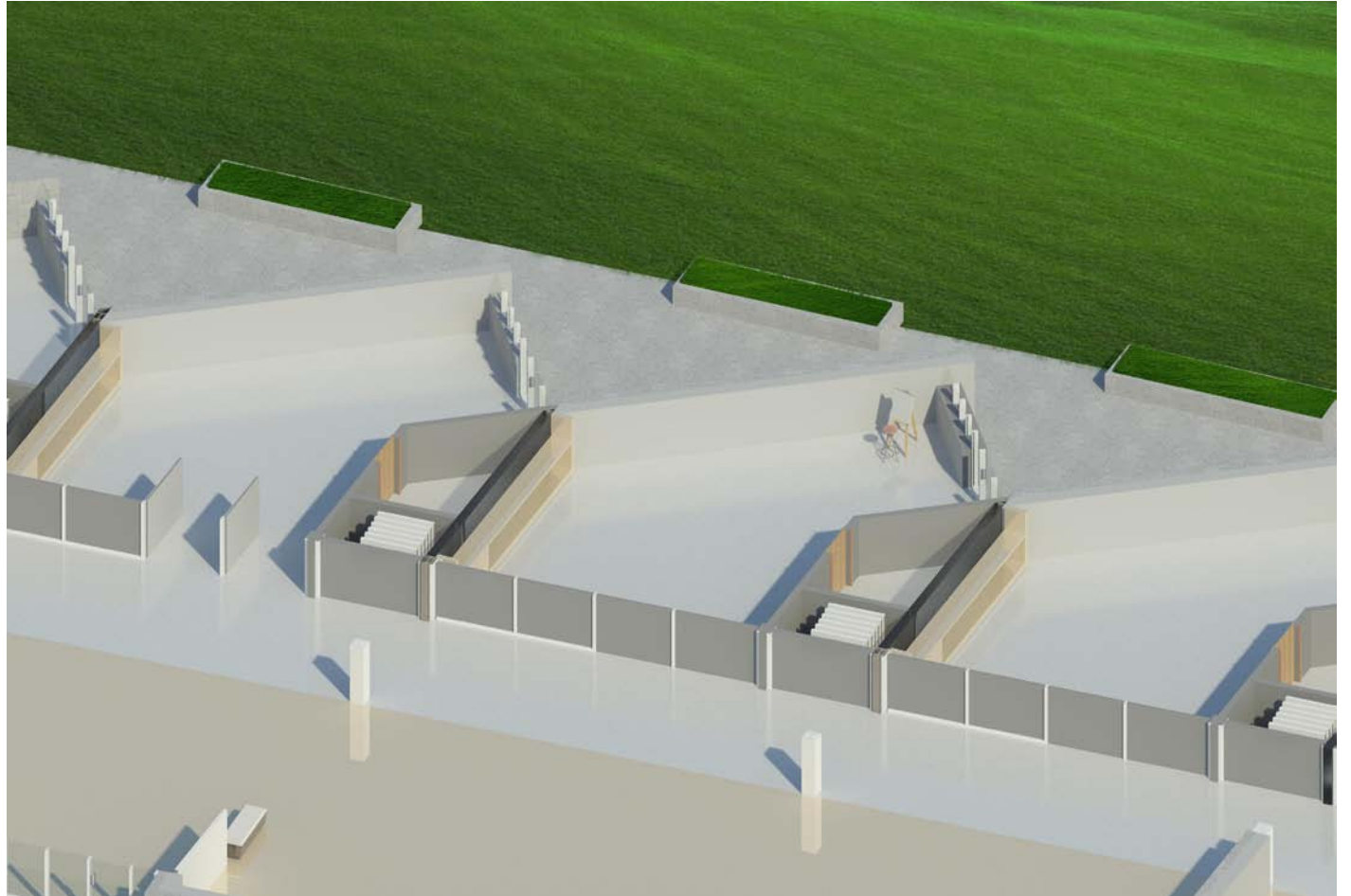
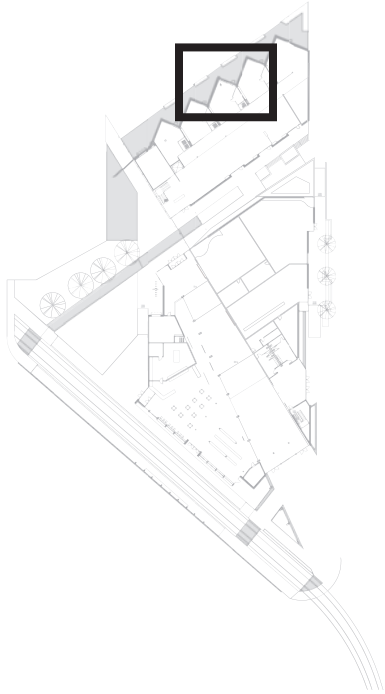

Systems [Passive]

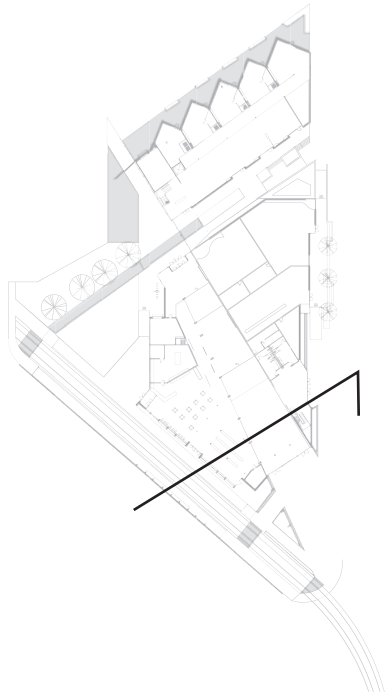

Solar Utilization
- Daylighting
- Photovoltaics

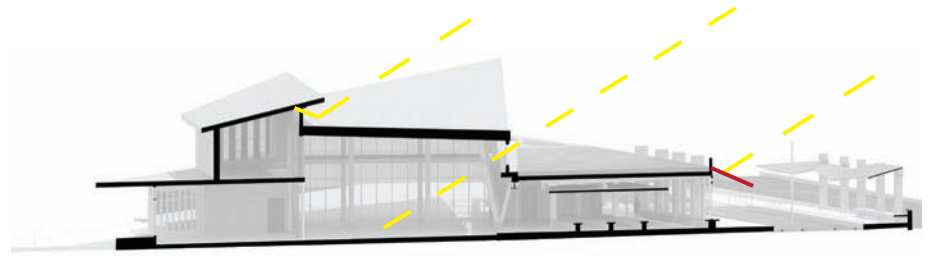

Operable Windows
- Natural Ventilation

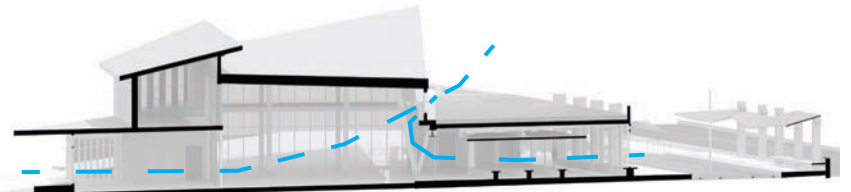

Green Roof
- Insulation
- Stormwater Runoff

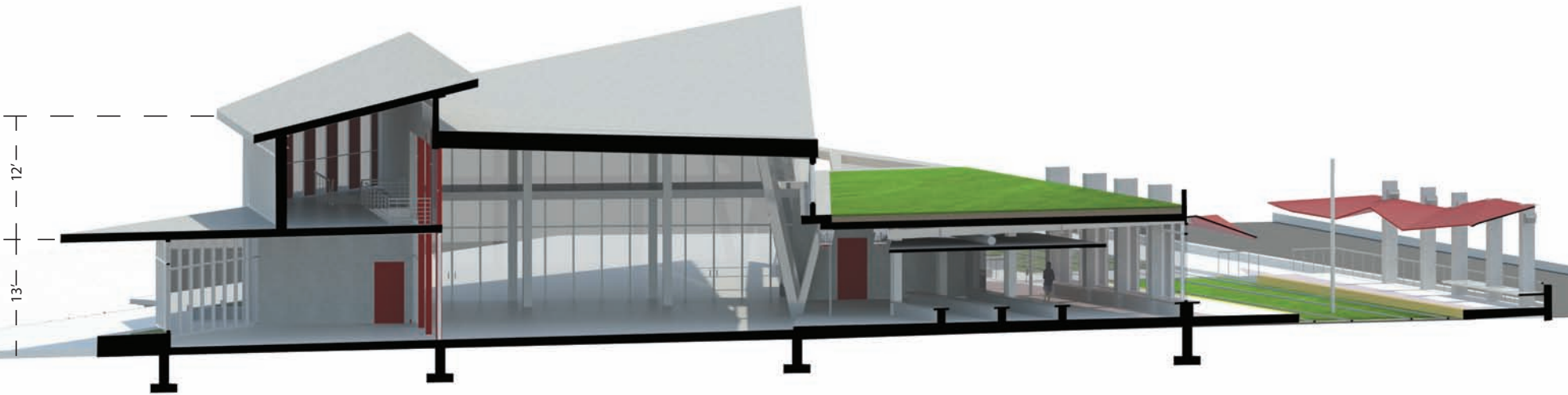
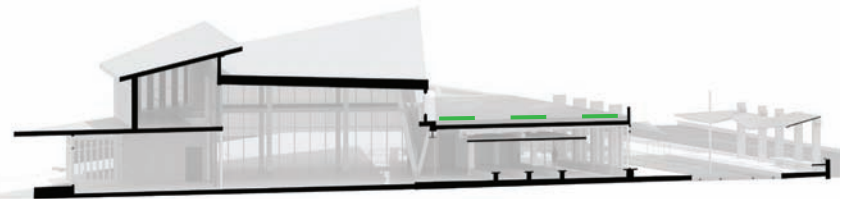

Systems [Active]



Forced Air
- Variable Air Volume

Important for air circulation in Art Studios.

Materials

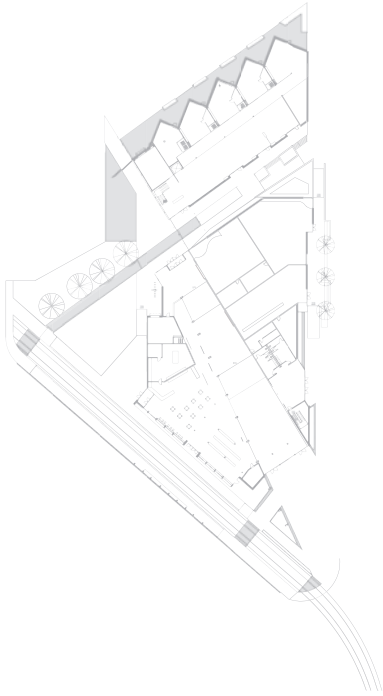

3 Form Red Chroma



Structural Steel Frame

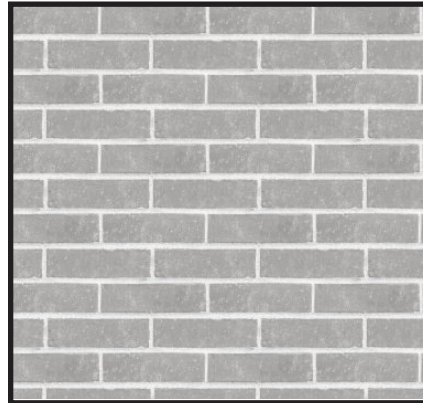

Light Brick Facade

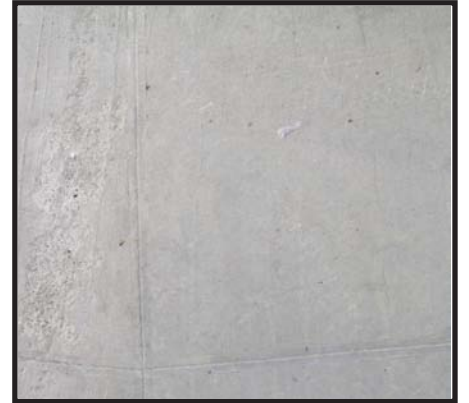

Concrete on Metel Deck

Changing Boundaries

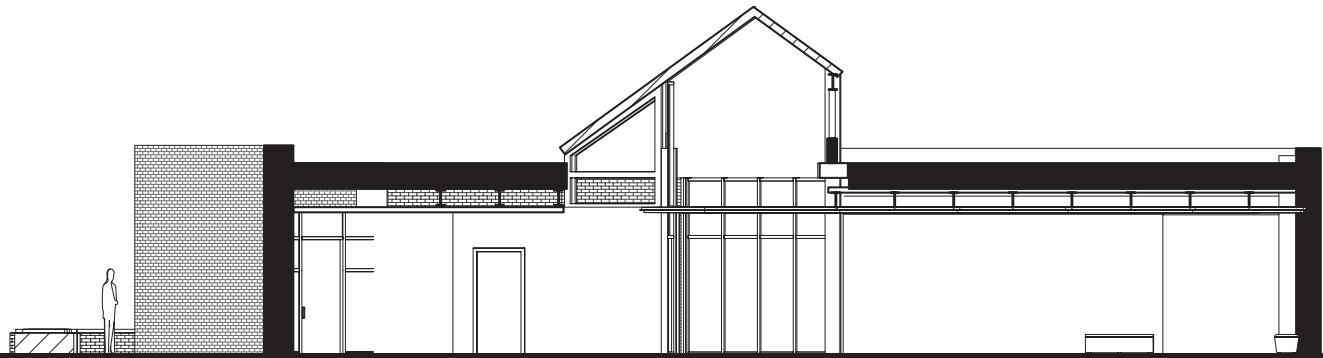
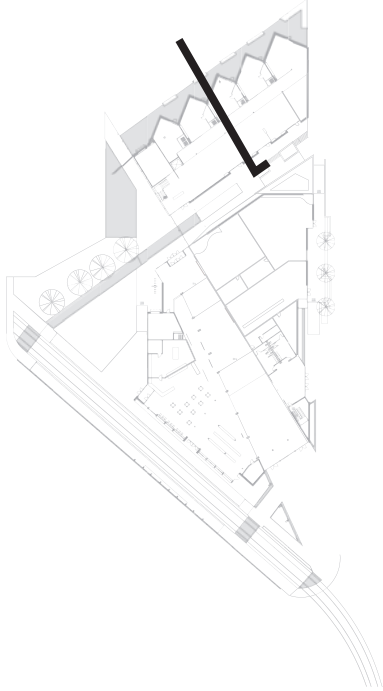

Changing Boundaries [Moving Walls]

CASESTUDY

STOREFRONT FOR ART AND ARCHITECTURE

ARCHITECT STEVEN HALL
NEW YORK, UNITED STATES



Changing Boundaries [Moving Walls]

4' Wide
4" Depth
Welded Steel Frame

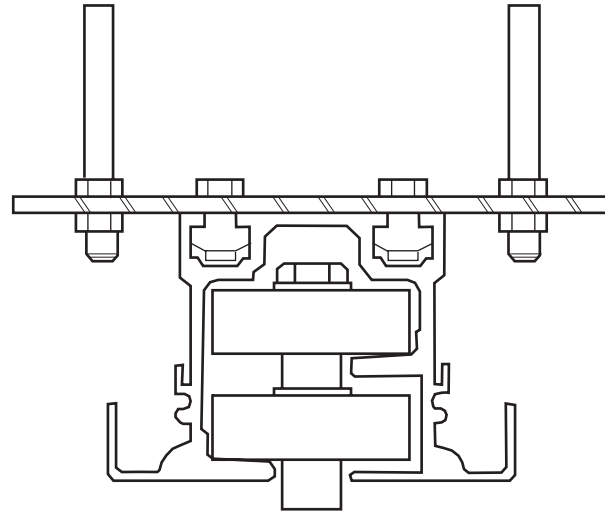

Changing Boundaries

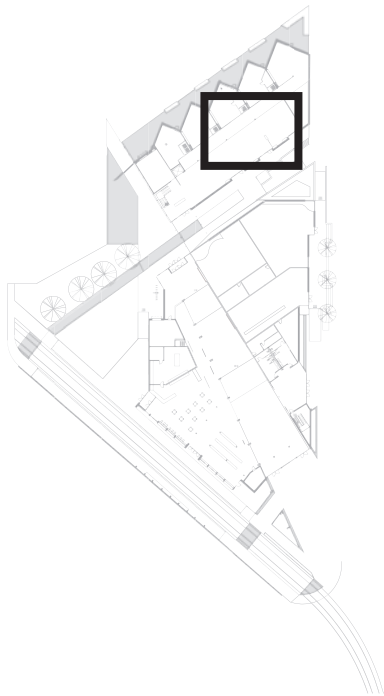

Changing Boundaries

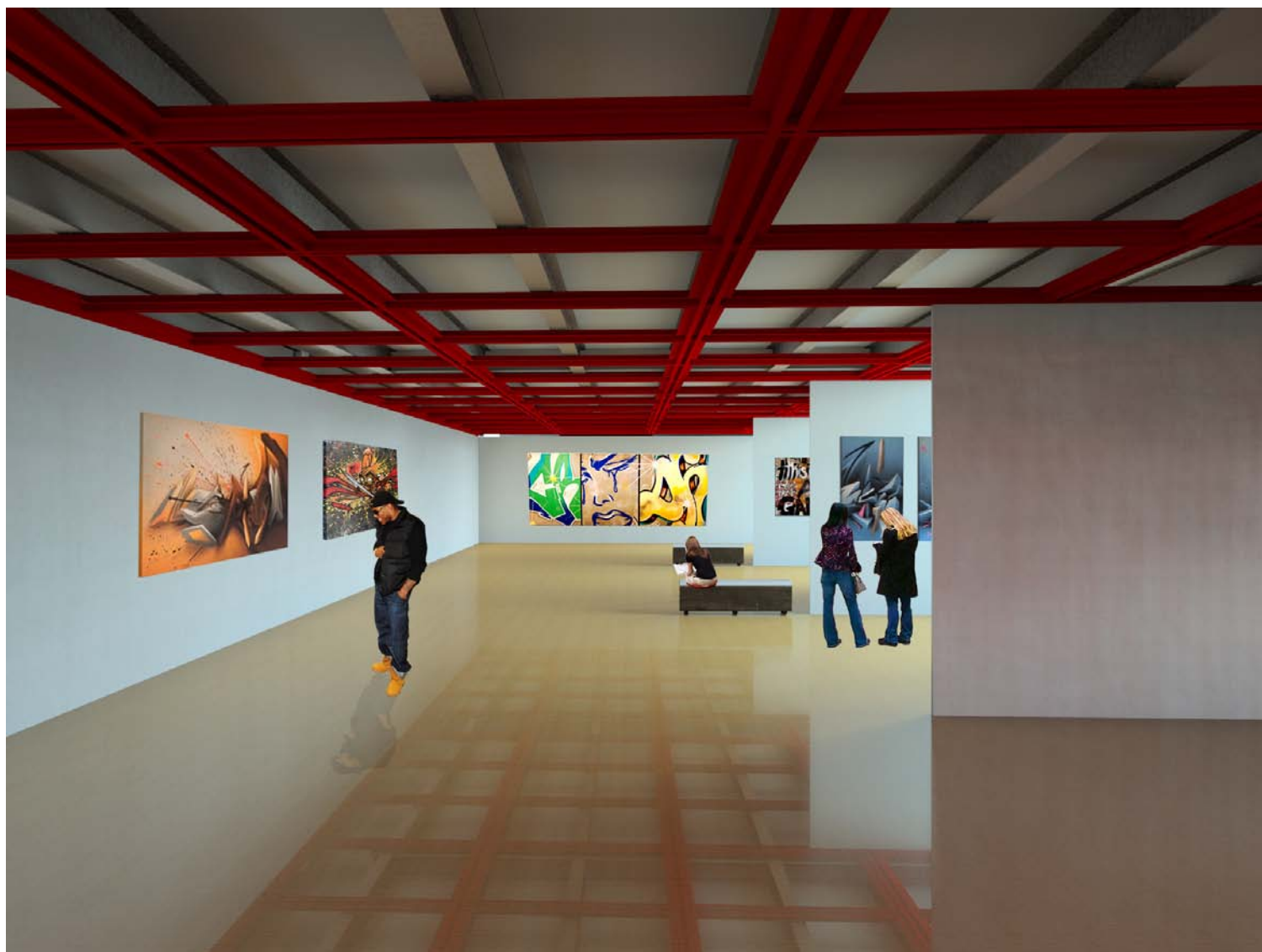
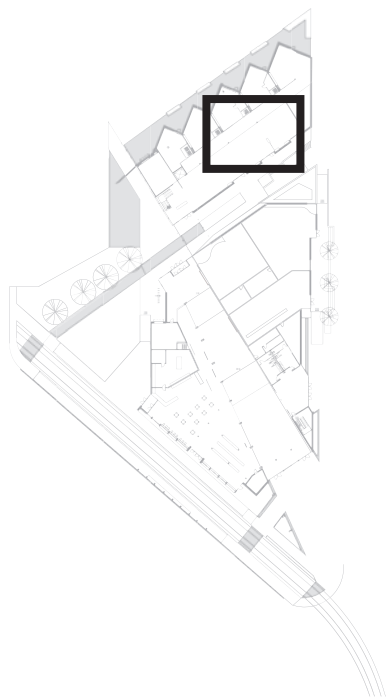

Changing Boundaries

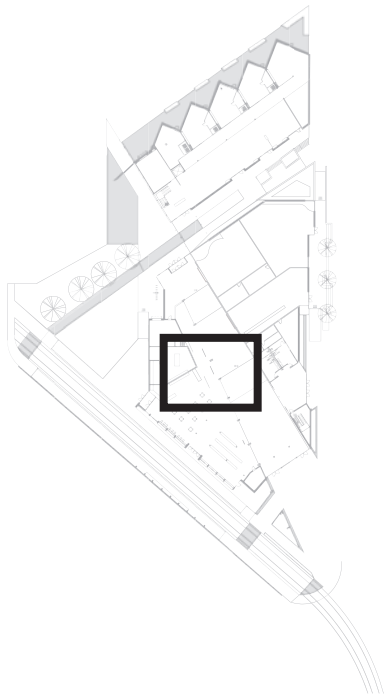

Front Perspective



 **Thank You!**

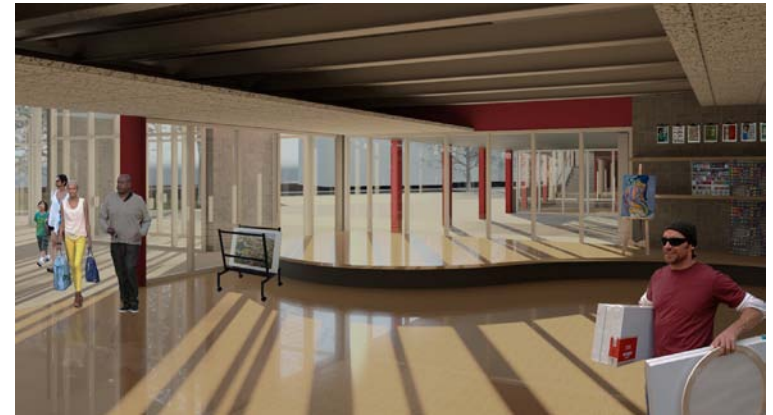

Questions - Comments