

THE MYTH OF SUSTAINABLE CULTURE

**THE NATIONAL MUSEUM OF
GEMS, METALS & MINERALS**



THE MYTH OF SUSTAINABLE CULTURE
THE NATIONAL MUSEUM OF GEMS, METALS & MINERALS

A Design Thesis Submitted to the
Department of Architecture and Landscape Architecture
of North Dakota State University

By

Matthew Louis Qual

In Partial Fulfillment of the Requirements
for the Degree of
Master of Architecture

Primary Thesis Advisor

Thesis Committee Chair

May 2015
Fargo, North Dakota

Table of Contents

1.0	List of Tables and Figures	4
2.0	Thesis Abstract	7
3.0	The Narrative of the Theoretical Aspect of the Thesis	8
4.0	The Project Typology	14
5.0	The Typological Research	16
6.0	Major Project Elements	52
7.0	User/Client Description	53
8.0	The Project Emphasis	54
9.0	Goals of the Thesis Project	56
10.0	Plan for Proceeding	58
20.0	Results From Theoretical Premise	64
21.0	Project Justification	76
22.0	Historical, Social, and Cultural Context of Thesis	78
23.0	Site Analysis	84
24.0	Final Building Program	118
30.0	THE DESIGN	122
31.0	Artefact	136
32.0	Site Re-introduction	138
33.0	Process Models	140
34.0	Final Model	142
35.0	Final Design	150
36.0	Approach	162
37.0	Program Appendix	184
38.0	References	192
39.0	Previous Studio Work	194
40.0	Bio	196

1.0 List of Tables and Figures

3	TOCN Table Of Contents	
14	PTYP “The Searchlight” Rhodocrosite	Figure 4.2
16	DAM The Denver Art Museum	Figure 5.2
16	NREL National Renewable Energy Laboratory	Figure 5.3
16	RODN Roden Crater	Figure 5.4
19	DAM Entry Stair	Figure 5.5
20	DAM Circulation Space	Figure 5.10
20	DAM Stair Light	Figure 5.11
20	DAM Stair Approach	Figure 5.12
20	DAM The Point	Figure 5.13
21	DAM Geometry Study	Figure 5.14
22	DAM Enlarged Ground Level Plan	Figure 5.15
23	DAM All Floor Plans	Figure 5.21
25	DAM Elevation	Figure 5.22
25	DAM Section	Figure 5.23
26	DAM Short Sections Glazing	Figure 5.24
27	DAM Long Section Glazing	Figure 5.25
29	DAM Structure	Figure 5.31
31	NREL Interior	Figure 5.32
32	NREL Office Section	Figure 5.33
33	NREL Laboratory Floor Plan	Figure 5.34
35	NREL Wall Section	Figure 5.35
37	NREL Figure Ground Perspective for Light and Mass	Figure 5.41
38	NREL Heating Loop	Figure 5.42
39	NREL Server Heat Section	Figure 5.43
41	RODN Overall Site Plan	Figure 5.44
42	RODN Night Oculus	Figure 5.45
42	RODN Oculus Zoomed	Figure 5.51
43	RODN Oculus Interior	Figure 5.52
44	RODN Tunnel Dark	Figure 5.53
44	RODN Tunnel Light	Figure 5.54
44	RODN Tunnel Oval	Figure 5.55
44	RODN East Entrance	Figure 5.61
45	RODN Looking Back	Figure 5.62
45	RODN East Portal	Figure 5.63
46	RODN Observatory Cross Section Model	Figure 5.64
46	RODN Pinhole Cross Section Model	Figure 5.65
47	RODN Details of Naked-Eye Observatory	Figure 5.71
47	RODN Moon Space Cross Section Model	Figure 5.72
47	RODN North Space Cross Section Model	Figure 5.73

49	DAM	Interior Perspective	Figure 5.74
50	NREL	Lab Interior	Figure 5.75
51	RODN	Observatory Night Sky	Figure 5.81
64	RFTP	Georgetown Colorado c. 1879	Figure 20.11
67	RFTP	Moi Statues on Easter Island	Figure 20.12
67	RFTP	Martin Heidegger	Figure 20.13
68	RFTP	Hans-Georg Gadamer	Figure 20.14
69	RFTP	NREL Campus	Figure 20.15
70	RFTP	Alberto Pérez-Gómez	Figure 20.21
77	PJST	Bruder Klaus Chapel	Figure 21.11
79	HSCC	Georgetown Map c. 1867	Figure 22.11
80	HSCC	Prytaenion Perspective	Figure 22.12
81	HSCC	Goddesses With Rare Stones	Figure 22.13
82	HSCC	Denver Skyline Highlighting Mountains	Figure 22.14
83	HSCC	Georgetown Colorado Downtown	Figure 22.15
84	SITE	U.S.A. Topographic Map Highlighting Site	Figure 23.11
86	SITE	Modified Birds-Eye View Showing Site	Figure 23.12
89	SITE	Image Overlooking Georgetown and Site	Figure 23.13
91	SITE	Digitally Drawn Overall Site Map	Figure 23.14
92	SITE	Site View Map	Figure 23.15
93	SITE	North Lake	Figure 23.21
93	SITE	South Site Overlook	Figure 23.22
93	SITE	East of Site	Figure 23.23
93	SITE	Western Silver Plume Mountain	Figure 23.24
93	SITE	Looking Down	Figure 23.25
95	SITE	Site Section	Figure 23.31
96	SITE	Site Map Various Features	Figure 23.32
97	SITE	Shadows and Vegetation of East Mountain	Figure 23.33
98	SITE	Site Fly-through Overlook	Figure 23.34
99	SITE	Topo/Shadow Map Highlighting Overall Town	Figure 23.35
99	SITE	Topo/Shadow Map Highlighting Site	Figure 23.41
100	SITE	Overall Site Vegetation/Lighting	Figure 23.42
101	SITE	Reference Map	Figure 23.43
102	SITE	Looking North	Figure 23.44
103	SITE	Reference Map	Figure 23.45
104	SITE	Looking South to Townscape	Figure 23.51
105	SITE	Reference Map	Figure 23.52
106	SITE	Looking East	Figure 23.53
107	SITE	Reference Map	Figure 23.54
108	SITE	Looking West to Silver Plume	Figure 23.55
109	SITE	Reference Map	Figure 23.61
110	SITE	Sun Path Diagram Overlaid On Site	Figure 23.62
111	SITE	Wind Rose Diagrams	Figure 23.63
112	SITE	Solar Gain	Figure 23.64
112	SITE	Estimated Fuel Use Proportions	Figure 23.65
113	SITE	Relative Humidity	Figure 23.71
113	SITE	Bulb Temperatures	Figure 23.72

114	SITE	Rain and Snow Table	Figure 23.73
115	SITE	Climate Zone Map Showing Topography	Figure 23.74
116	SITE	Georgetown & Colorado Demographics	Figure 23.75
116	SITE	Georgetown Population by year	Figure 23.81
116	SITE	Crime Rates in Georgetown	Figure 23.82
117	SITE	Jobs	Figure 23.83
118	FBPR	Final Building Program Table	Figure 24.11
119	FBPR	Space Allocation Matrix	Figure 24.12
121	FBPR	Space Connectivity Web	Figure 24.13
125	DSGN	Hans Georg Gadamer	Figure 30.11
126	DSGN	NREL Campus	Figure 30.12
127	DSGN	Alchemical Cosmos	Figure 30.13
128	DSGN	Martin Heidegger	Figure 30.14
130	DSGN	Luca Pacioli	Figure 30.15
131	DSGN	Saint Denis	Figure 30.21
132	DSGN	Bruder Klaus	Figure 30.22
134	DSGN	Voluptus, Chastity, Beauty	Figure 30.23
137	DSGN	Artefact	Figure 31.11
138	DSGN	Historic Georgetown Photo	Figure 32.11
139	DSGN	The Site	Figure 32.13
140	DSGN	Process Models	Figure 33.11
143	DSGN	Final Model	Figure 34.11
151	DSGN	Site Context Map	Figure 35.11
152	DSGN	Building Section	Figure 35.12
153	DSGN	Plans	Figure 35.13
154	DSGN	Building Section	Figure 35.14
156	DSGN	Split System	Figure 35.15
156	DSGN	System Diagrams	Figure 35.21
158	DSGN	Thermal Chimney Detail	Figure 35.22
158	DSGN	Thermal Chimney Diagram	Figure 35.23
159	DSGN	System Diagrams & Details	Figure 35.24
160	DSGN	Structure Diagrams & Details	Figure 35.25
162	DSGN	Approaching	Figure 36.11
164	DSGN	Entering	Figure 36.12
166	DSGN	Weaving	Figure 36.13
138	DSGN	Outlook	Figure 36.14
170	DSGN	Light Frame	Figure 36.15
172	DSGN	Ascent	Figure 36.21
174	DSGN	Oculus	Figure 36.22
176	DSGN	Wedge Base	Figure 36.23
177	DSGN	Sky Lens	Figure 36.24
180	DSGN	Wave Well	Figure 36.25

Thesis Abstract

As Hans-Georg Gadamer explains, because modern society is so focused on specialization, medicine and health have become disjointed from common knowledge. Similarly, sustainability is often unrealizable to the users of a building through their experience. This is due to the specialized application of sustainable technology in the form of complex systems. Such issues are important because architecture has always been meaningfully perceived through the lived-experience of the body. In fact, looking to history, one will find that the root of sustain is *Sustinere* – To Hold. Is it possible to examine sustainability as both an experiential phenomena and a specialist's application of technology to a building?

When Martin Heidegger defined dwelling, he defined it as a means of sustainable discourse as well as a relation of the body to the surrounding world. Located in Georgetown Colorado, the design integrates sustainable technology into the experience of architecture rather than being an applied formulaic system alone. The building, inspired by the wonder of a gem, acts as a bridge between sustainable practices and the body, the world and greater culture, the individual and the cosmos.

Narrative of the Theoretical Aspect of the Thesis

In recent years, sustainability has been a catchphrase which is associated as being a staple in future human progress. Sustainability has been recently practiced as a specialized formula for a healthy world. It has lost its roots of being one's effect on the environment, and has been seen by the masses as something which is out of the individuals control. Instead of taking action, many individuals see it as too specialized a problem to be within their own control. Through this platform, the practice has become an application which is self-referential in that it has no deeper context to human history other than being a mechanical response to a human engendered problem.

The word itself roots from an action. In order to understand the premise of the idea, one must deconstruct the word sustainability; sustain- to withhold, and ability- the means to do something. Sustain is rooted around 1250 AD, deriving from the middle english *suste (i) nen-* which roots from Anglo-French *susteinr*, and Latin *sustinere* which means *to hold*. The word sustainability roots from a human perspective, through experience; once implying the bodily action of holding something within one's own hands. The origin is relatable in a phenomenological way which has become unapparent in the modern day view of the action of being sustainable.

One can observe that people often see things for their face value, and if something is not in human perspective and made available through human sensations, people will often accept its existence without further exploration. For example, let's look at a technology which is closer to humans than any other in modern times- the smart phone. The smart phone today would be seen as magic or witchcraft in earlier time periods. Yet even with modern day scientific thought, is still as enigmatic. People hold these devices and know how to use them, but most have no idea how the device works. Modern technology dwells in the realm of the specialist. There is no context to draw from in the average person's lived experience that hints at how most modern technology works, so they take for granted that it does and explore no further. Sustainable practices have also held the same fate. Moving forward with sustainable technology is not true progress unless people understand what the context of sustainability is. Sustainability is a response to a problem which originated with humans and their effect on the environment. Oftentimes there is a disconnect between what people see as the result of sustainable practice in a building and how it works. Most times, the extent of public involvement lies in a plaque which hangs on the wall stating the buildings objective ability to follow a formula. I am interested in bringing fourth the systems and practices into the realm of the public, beyond the specialist, in a way that people can truly relate to and start to contextualize why it is even there. It is often forgotten why sustainability exists-

It would not be a 'thing' if it were not that culture has spawned a belief that excess is good; That unless one lives in excess

one is losing.

Since the development of the perspective this type of thinking has been prominent.

The perspective is one of the few tools that architects have that can instantly relay an idea in a way that is very clear to the public. The contradiction of the tool is that it cannot be anything but an objectification of experience. Through its self reference, the reduction of reality is represented in a way which has no further value than itself in its own ocular-centric image. Scientific thought developed thereafter, where experience can now be explained through a Cartesian grid instead of through a multitude of senses and deeper cultural references. Through this thought process, nearly everything in our daily lives can be reduced to something which is positive, or something which is negative. One might question the context of how things are positive or negative. Is something positive for you or positive for me? But what of the further repercussions? The tragedy of Cartesian thinking is since things are reduced to either good or bad, there is no longer a balanced median-the appropriate. A comparison between scientific and appropriate thought could poetically be compared as the difference between, as Heidegger references, strip mining and a plow turning the soil. The difference between breaking an object apart and studying its contents, and turning something in ones hands and letting the object reveal itself to oneself.

In the journal article *On the Relevance of Phenomenology* (Vesely, 1988), Dalibor Vesely says that “Science and technology are ultimately privileged constructions which have not been brought into an adequate confrontation with a cultural reality broader than themselves.” Architecture has taken a similar turn into self-referential embodiment. Sometime around the development of the perspective, Vesely theorizes, can be seen as a turning point in human thought. Before the development of the perspective, everything referenced something else. There was no end-all ocular-centric and omni-sensual representation of anything, rather things were seen as the embodiment of the thing and its environment. Environment of course is not limited to immediate surroundings but rather a much broader context of culture, site, and one's place in the cosmos.

The ‘building’ is analyzed in terms of its existence and its setting. One without the other would not be a complete existence beyond an object. Vesely describes a building as being the fabric of the experience, and explains that the role of the context plays an even more important role than any other physical form or geometry. The problem with many modern architects is that the setting is often deemed less important than the form or geometrical relationships of the building itself. The building becomes an object to admire which only relates to itself and is reduced to a matter of aesthetic detailing and personal taste. There are no true meaningful artifacts that are merely self-referential - Those objects which can be reduced to a pleasant image which holds similar meaning.

In the book *The Eyes of the Skin*, Juhanni Pallasmaa also speaks about the importance of the environment and the architecture we place within it. The body is informed and shaped by the context of the environment. The lived experience permits different mentalities and attitudes which are directly endowed by natural and man-made atmospheres. These experiences and mentalities are reduced since we live in an ocular-centric world our other senses are lost in the myriad of visual stimuli, like the perspective, which are developed only to please the one sense. Truly, though, architecture is experienced in a much more interconnected sensory wholeness. Through touch, scent, and taste the Gothic cathedral expresses its dank timelessness. Through hearing, the echoes of footsteps on a cobblestone street express the ethereal silence of the European city. Through memory, the confrontations of material and form interact and bring meaning to architectural experience. Architecture is experienced through the oneness of the lived experience.

In the book *The Enigma Of Health* by Hans-Georg Gadamer, a dialogue about the specialist in our daily lives and our individual specialized nature is raised. He starts the book with the famous line from Kant's *Critique of Pure Reason*, that 'there is no doubt that all our knowledge begins with experience.' In the book, Gadamer argues that experience, or learned knowledge, is only actually gained if it is "integrated into the practical consciousness of acting human beings." (Gadamer, 1993) Consider the technique which sustainable practice is taught today. There is no knowledge to be gained beyond that of application of technology. To bring things to the human scale, there must be more involvement through the human experience.

Sustainability and architecture have been historically talked about as two different things having an affect on one another. Today's sustainable practice is a formulaic science which is currently seen as being applied to a building. "Architecture cannot, however, become an instrument of mere functionality, bodily comfort and sensory pleasure without losing its existentially mediating task. A distinct sense of distance, resistance, and tension has to be maintained in relation to the programme, function and comfort. A piece of architecture should not become transparent in its utilitarian and rational motives; it has to maintain its impenetrable secret and mystery in order to ignite our imagination and emotions." (Pallasmaa, 2005) Through the idea of the thesis, the merging of the two, sustainability and architecture, allows for clarity while at once still being enigmatic and culturally meaningful. Nature, architecture, and culture are one in the same, similarly sustainability in architecture should be one in the same with culture and nature.



Figure 4.2 "The Searchlight" Rhodocrosite - Excavated from Alma, Colorado near Georgetown.



The Project Typology

The National Museum of Gems, Metals & Minerals

Georgetown, CO. was founded during the Pike's Peak Gold Rush in 1858. While gold was the main drive for the initial rush, silver was later found to be nearly as valuable. The Georgetown silver mine is one of the area's current main public attractions which allows for the town to be a major tourist hub.

The typology of the museum was derived through this attribute, as well as others such as the high quantities of quartz and other minerals on site, the shimmering of the adjacent lake, and the mountain of metamorphic rock which is to the west of the site.

A geologic museum in particular is something which I believe most can appreciate, therefore it can relay the information of the sustainable aspects of the thesis in a deeper, and more meaningful way. Appreciating natural beauty is an inherent characteristic of every human. I believe that the beauty of nature is the base point that nearly every human uses to weigh the beauty of any other unnatural artifact. Therefore a building which celebrates this fact through its encryption of natural artifact in a human-designed environment will allow for further contextualization when analyzing the environment itself. Through this theory, I believe the integrated design will be allowed to speak to the sustainable aspects in a more meaningful and insightful way.

Typological Research

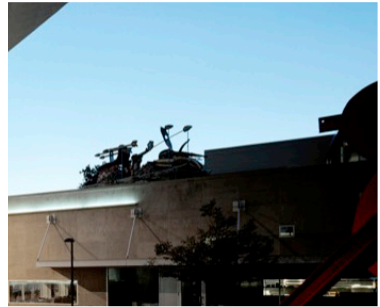
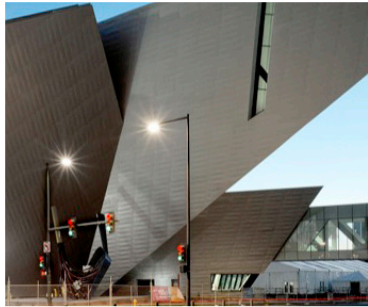
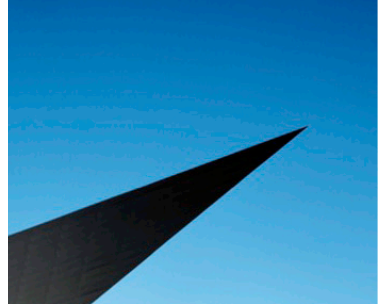


Figure 5.2 <http://www.archdaily.com/80309/denver-art-museum-daniel-libeskind/>

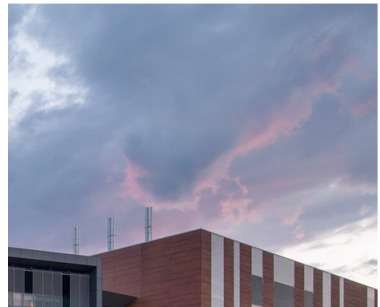
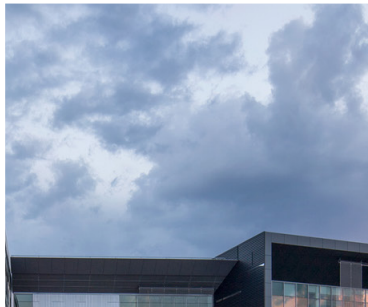
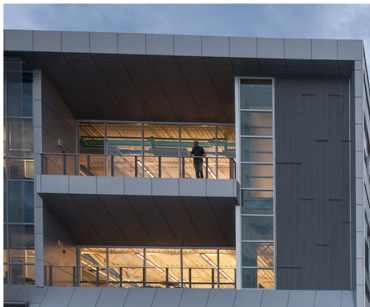


Figure 5.3 <http://www.archdaily.com/443969/national-renewable-energy-laboratory-smithgroupjir/>



Figure 5.4 http://3.bp.blogspot.com/-lsKSthw19j4/Uip_W99r5HL/AAAAAAAAIU8/qPDRck67bSI/s1600/roden+crater1.jpg



DENVER ART MUSEUM

Daniel Libeskind

Denver, Colorado

**NATIONAL RENEWABLE
ENERGY LABORATORY**

SmithGroupJJR/ RNL

Golden, Colorado

RODEN CRATER

James Turrell

Flagstaff, Arizona

DENVER ART MUSEUM

Daniel Libeskind

Denver, Colorado

The addition to the Denver Art Museum by Daniel Libeskind was built in 2006 is also known as The Fredric C. Hamilton Building. The existing museum was designed by the Italian Architect Gio Ponti. Most people who view the museum would be first drawn to it by the form. It is interestingly geotechnical in nature, referencing the breathtaking views of the rocky mountains.

One of the major challenges of the building's form was to frame light as it entered the building. I think it is an excellent case study for this reason. Since the program of the thesis relates directly to the control of light, and how it will interact with different precious minerals. Inspiration can be found inspiration in Libeskind's techniques.

Coined 'Nexus', The building responds to the Existing site by using similar aesthetic of the surrounding neighborhood. The greater denver area is developing a line of monuments by which the city plans to link neighborhoods through reference of sculpture and artifact.

STATISTICS

Studio Daniel Libeskind Building
146,000 SF Museum Addition
Geometric Form
10 Exhibition Spaces of Varying Size



Figure 5.5 Entry Stair. <http://www.archdaily.com/80309/denver-art-museum-daniel-libeskind/>



Figure 5.10 Circulation space.

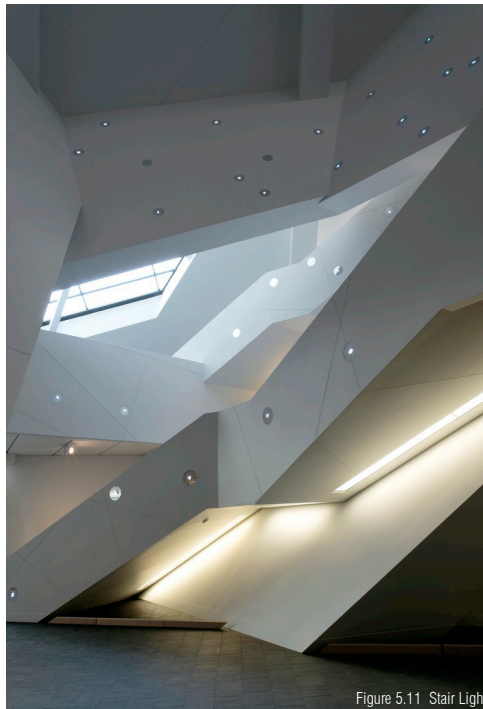


Figure 5.11 Stair Light.

Interior shots of the museum showing the lighting conditions of the spaces. The lighting in the building is located in a geometrical relationship to the form of the building. By so doing Lebeskind was able to highlight the exhibitions in a very particular way, as well as bring out high contrasting shadows through the architecture.

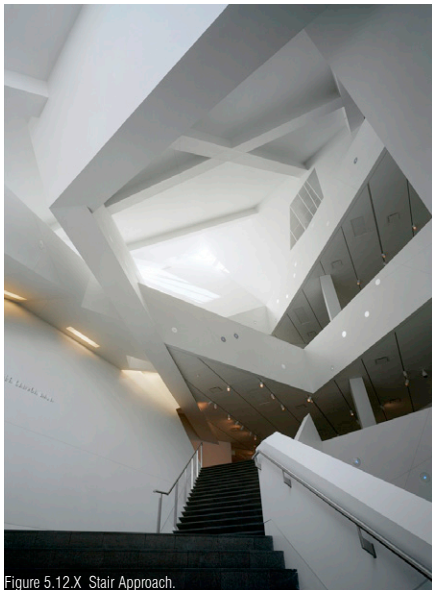
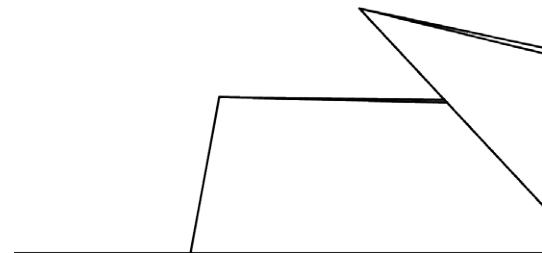


Figure 5.12.X Stair Approach.

Images: <http://www.archdaily.com/80309/denver-art-museum-daniel-libeskind/>

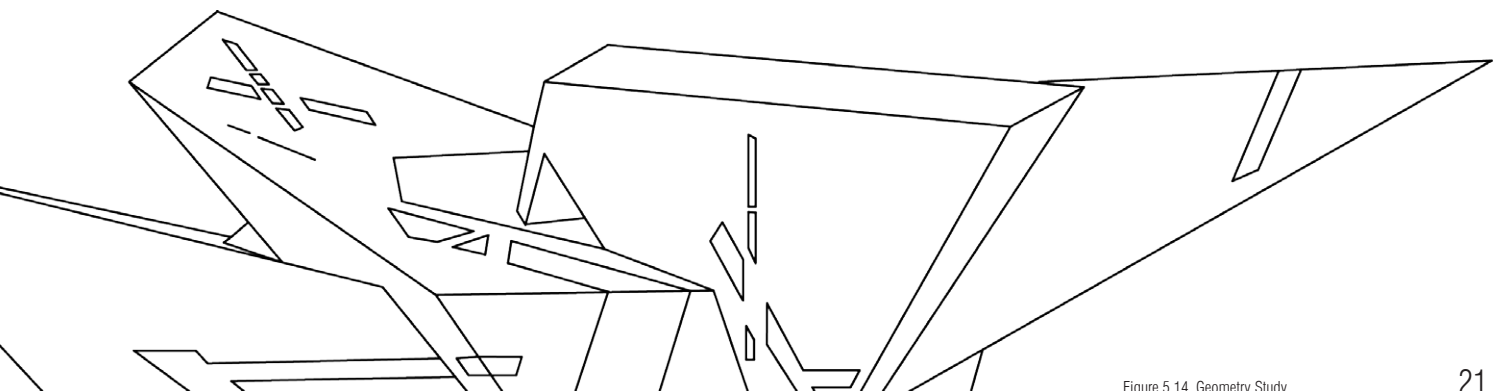


Figure 5.13 Lighting in the 'point' of the museum.



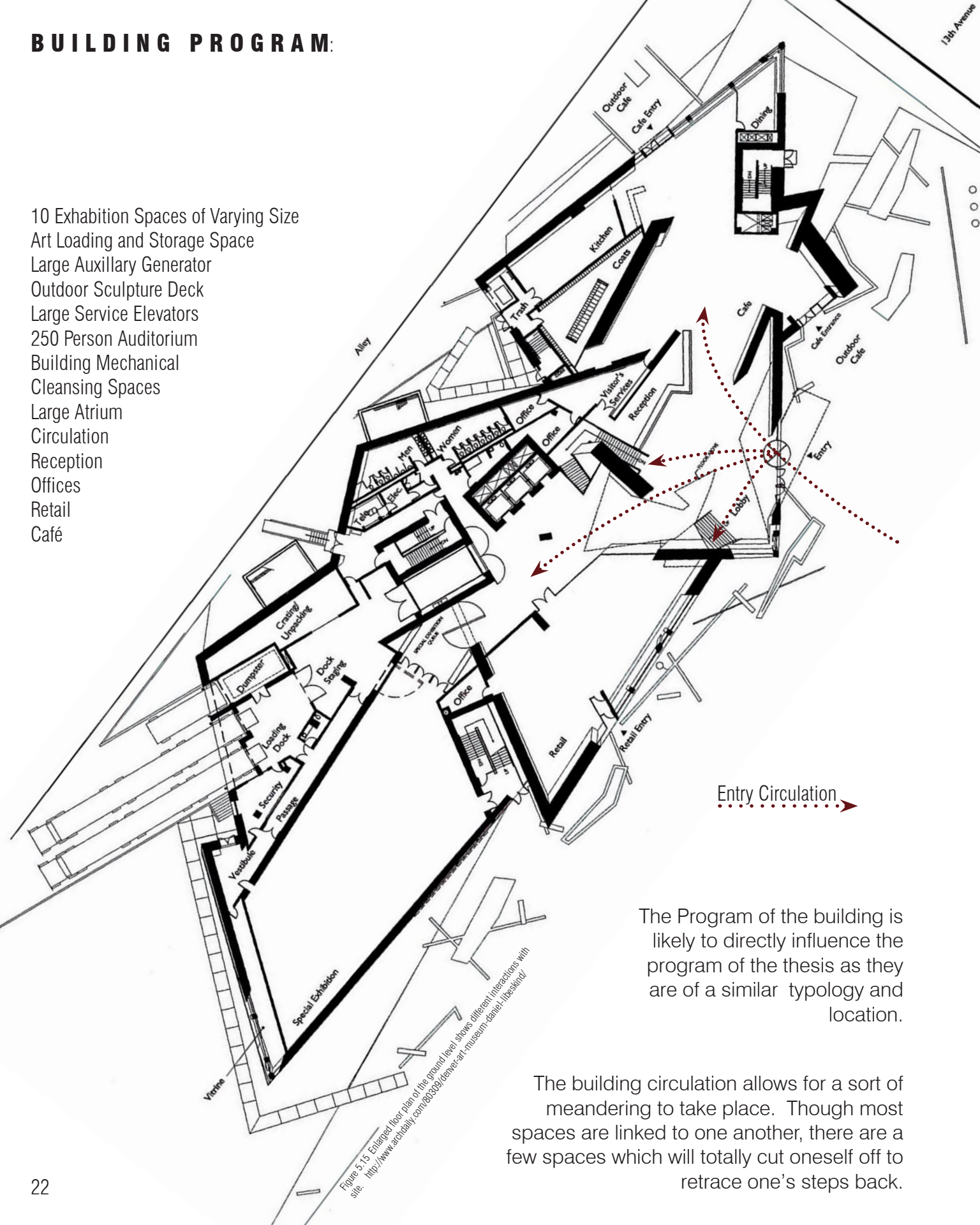
“The new building is not based on an idea of style or the rehashing of ready made ideas or external shape because its architecture does not separate the inside from the outside or provide a pretty facade behind which a typical experience exists; rather this architecture has an organic connection to the public at large and to those aspects of experience that are also intellectual, emotional, and sensual. The integration of these dimensions for the enjoyment and edification of the public is achieved in a building that respects the hand crafted nature of architecture and its immediate communication from the hand, to the eye, to the mind. After all, the language of architecture beyond words themselves is the laughter of light, proportion and materiality.”

-Daniel Libeskind



BUILDING PROGRAM:

- 10 Exhibition Spaces of Varying Size
- Art Loading and Storage Space
- Large Auxillary Generator
- Outdoor Sculpture Deck
- Large Service Elevators
- 250 Person Auditorium
- Building Mechanical
- Cleansing Spaces
- Large Atrium
- Circulation
- Reception
- Offices
- Retail
- Café

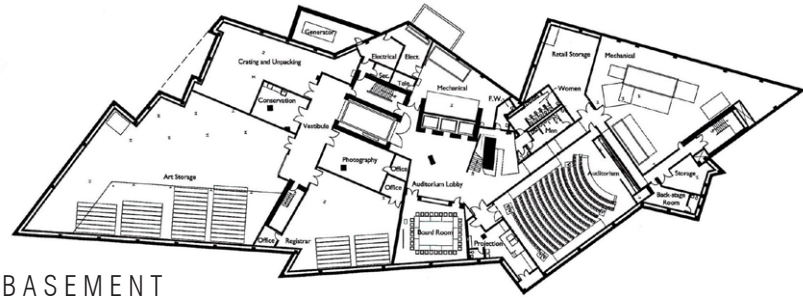


Entry Circulation →

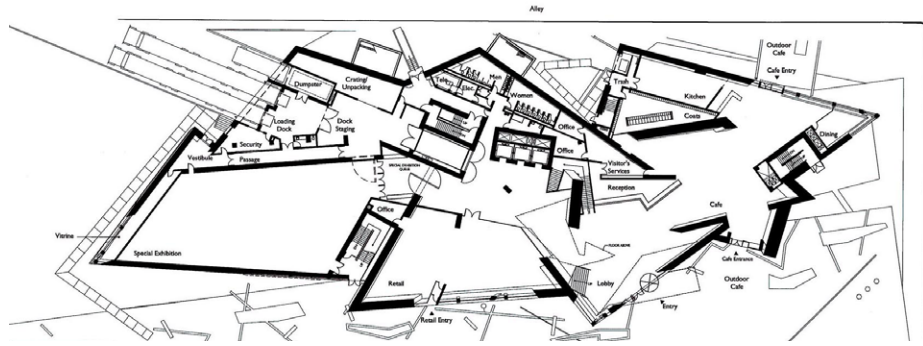
The Program of the building is likely to directly influence the program of the thesis as they are of a similar typology and location.

The building circulation allows for a sort of meandering to take place. Though most spaces are linked to one another, there are a few spaces which will totally cut oneself off to retrace one's steps back.

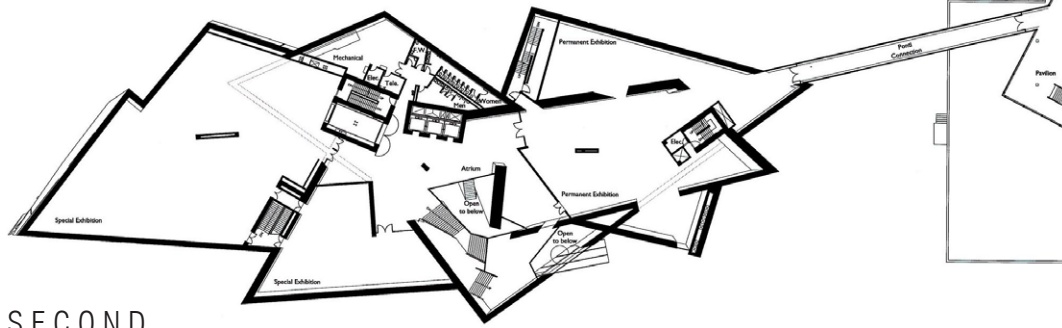
Figure 5-15 Enlarged floor plan of the ground level shows different interactions with site. <http://www.archdaily.com/800009/democracymuseum-chicago-thebuilding/>



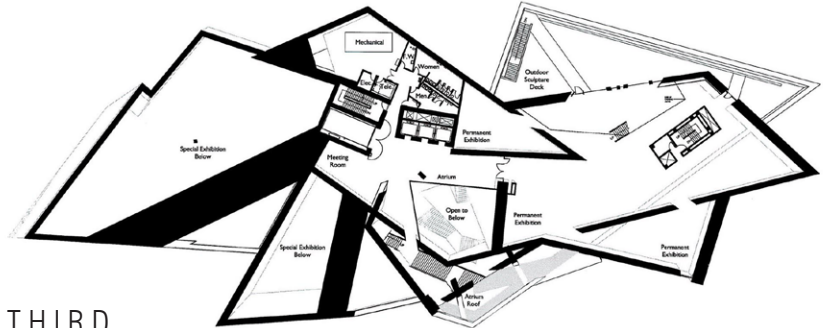
BASEMENT



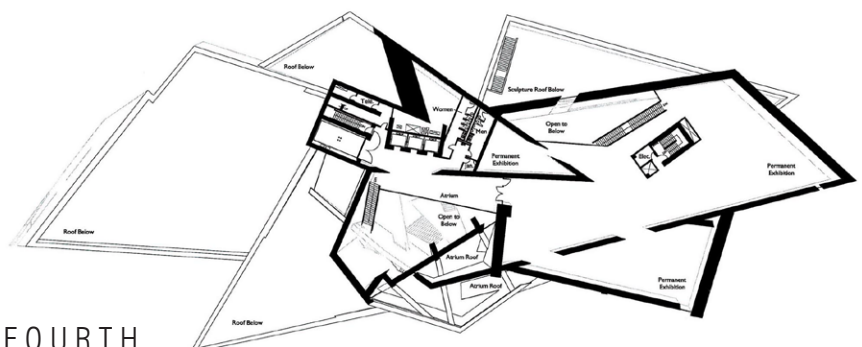
GROUND



SECOND



THIRD



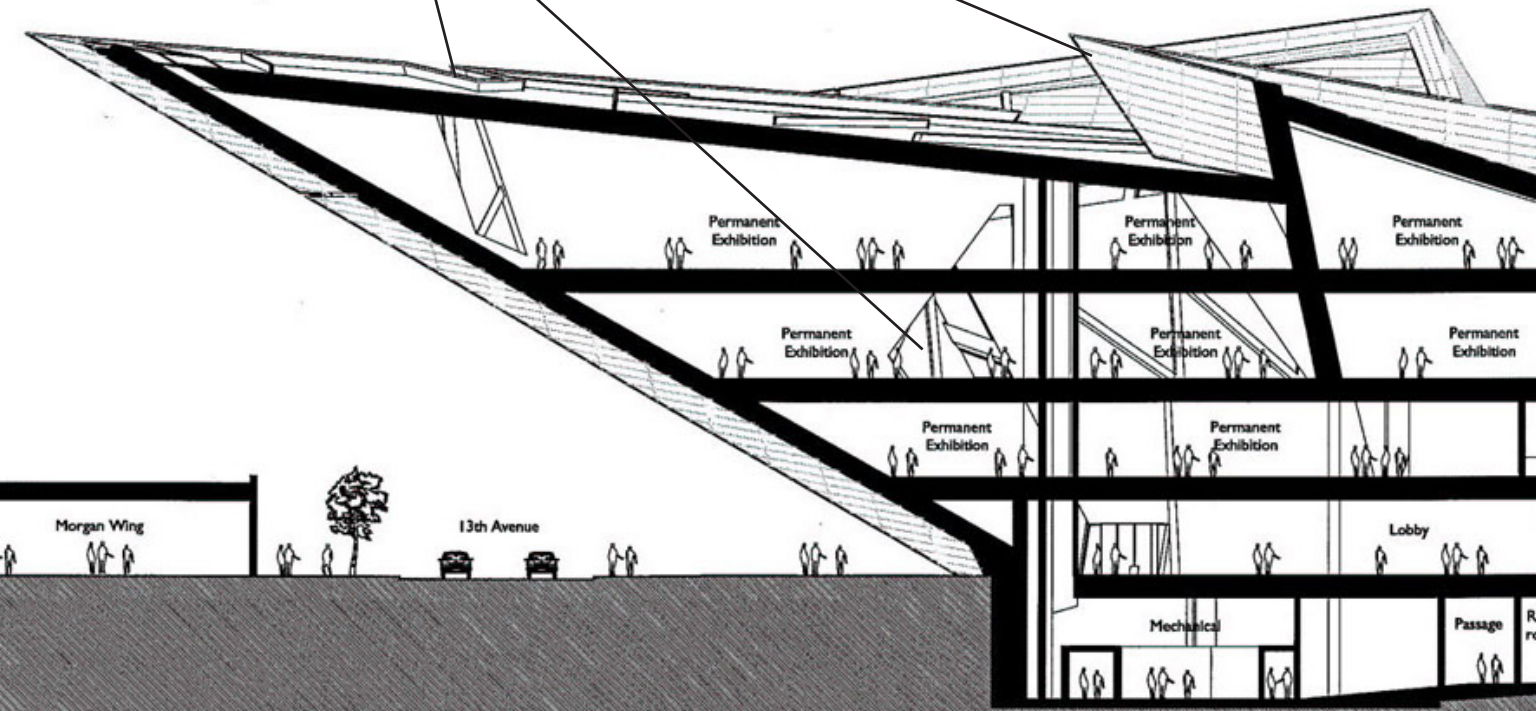
FOURTH

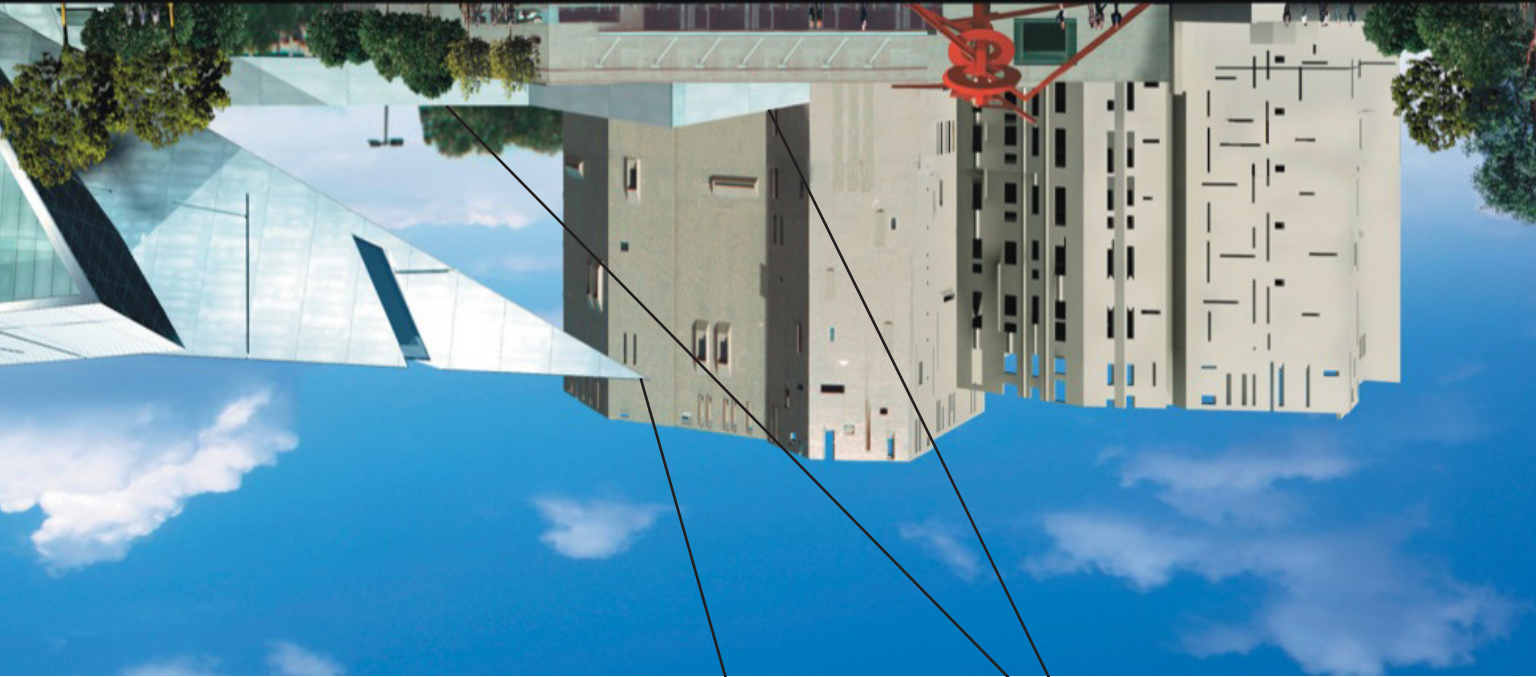
Figure 5.21 All above floor plans. <http://www.archdaily.com/80309/denver-art-museum-daniel-libeskind/>



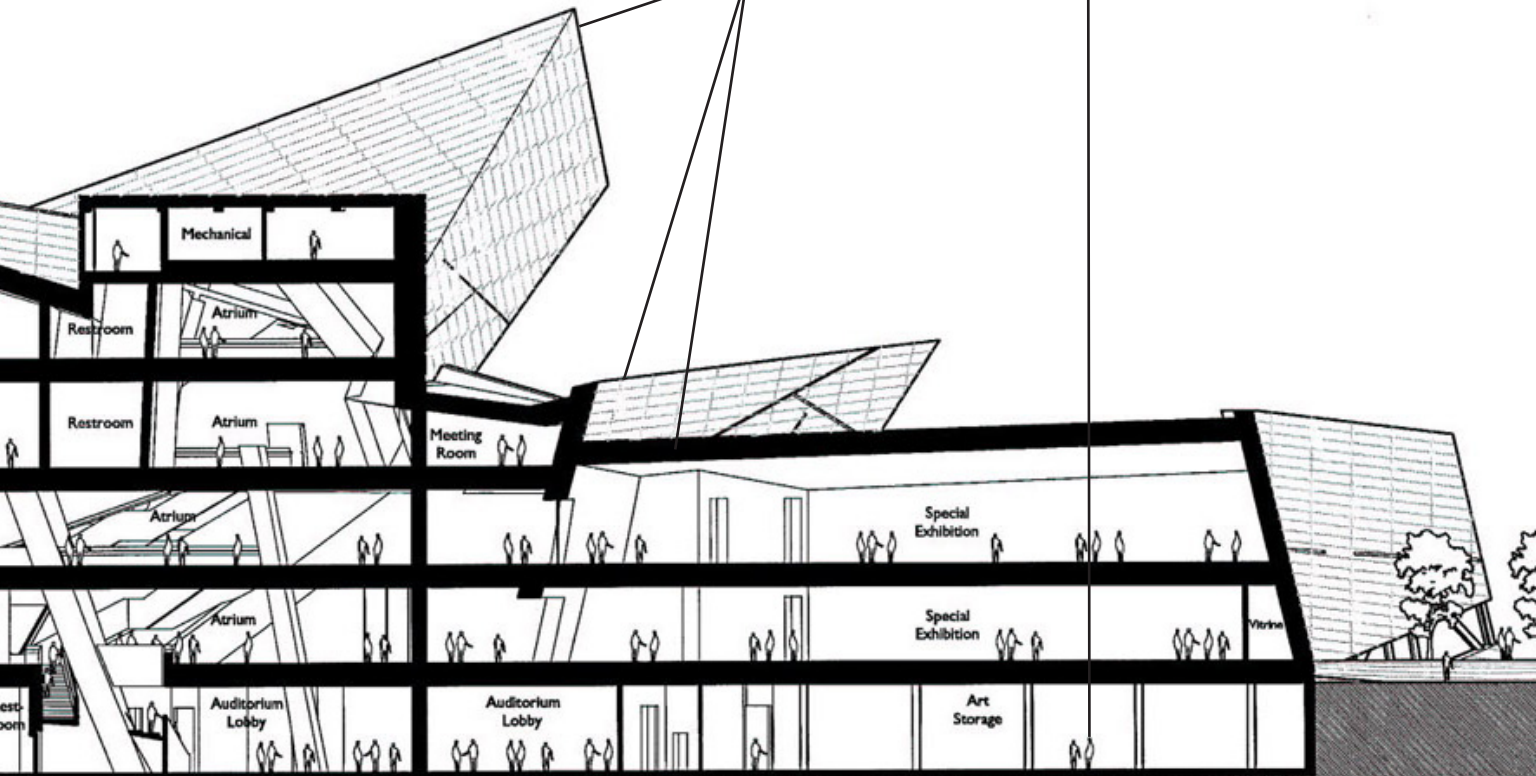
PUNCTURES

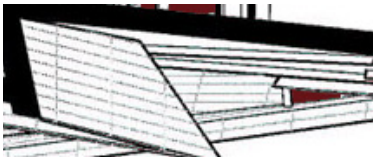
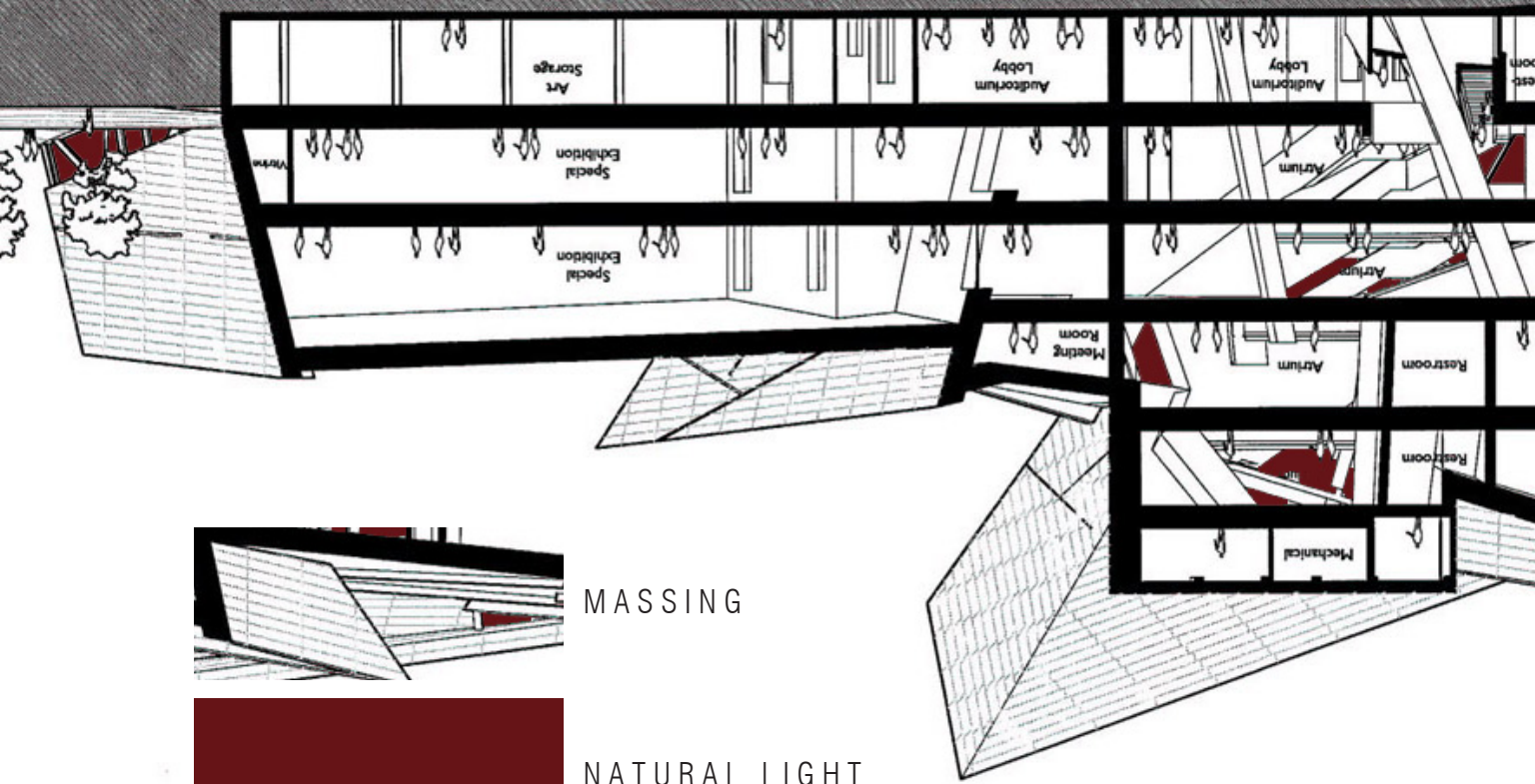
SKIN





CONNECTIONS
HEIRARCHY





MASSING



NATURAL LIGHT

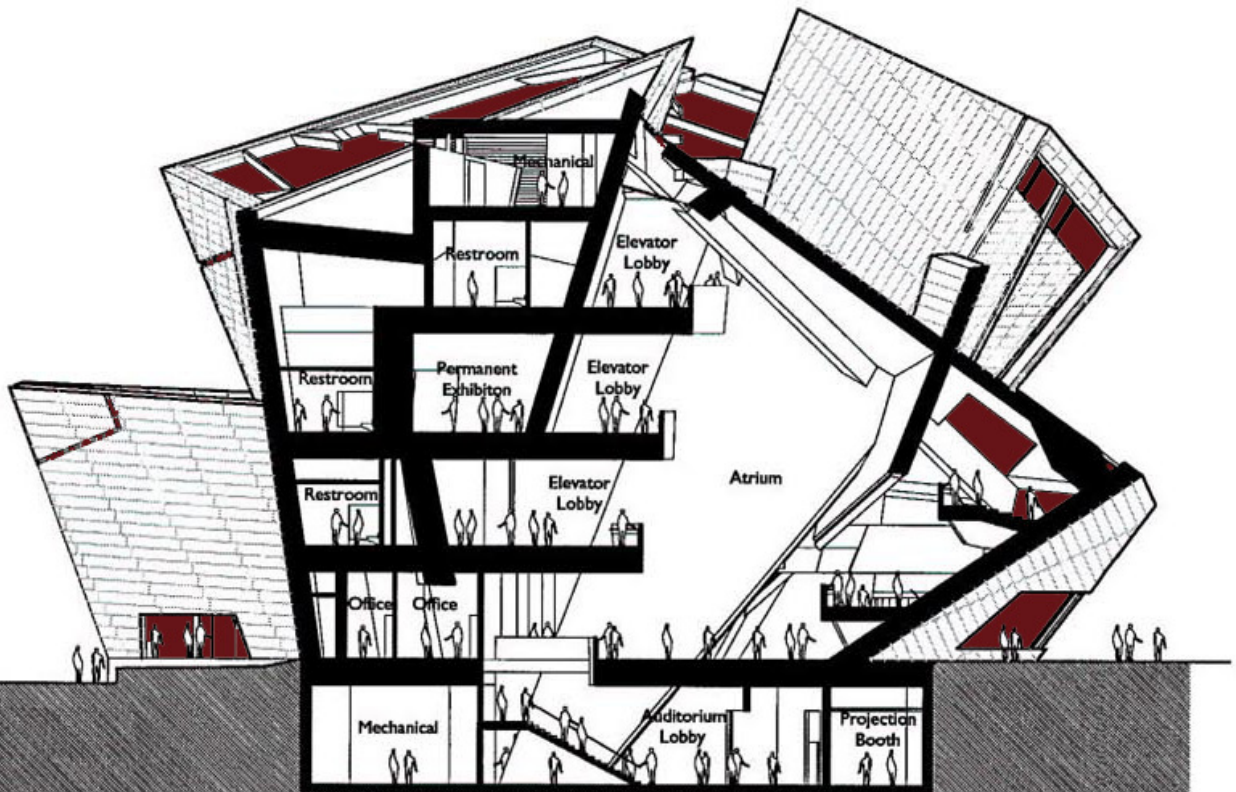
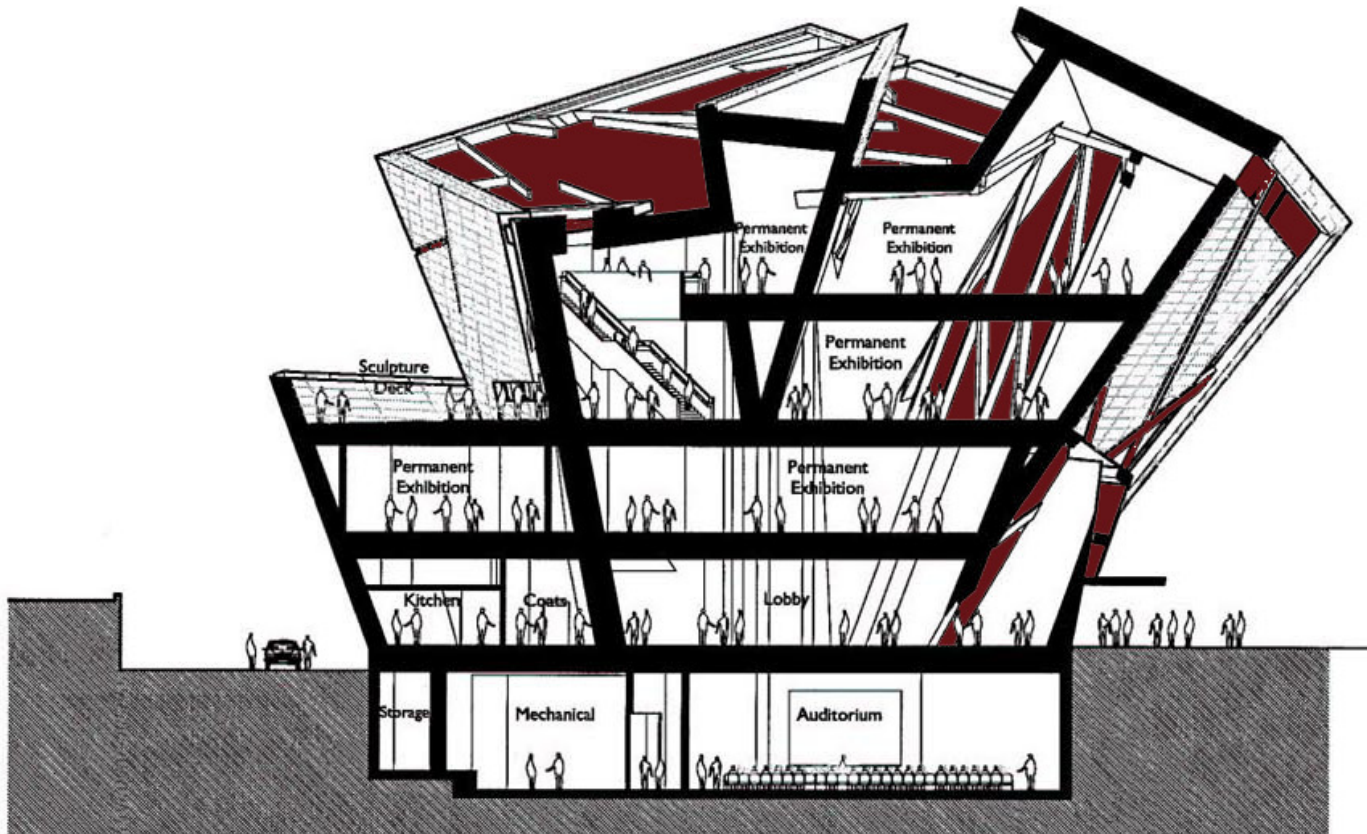
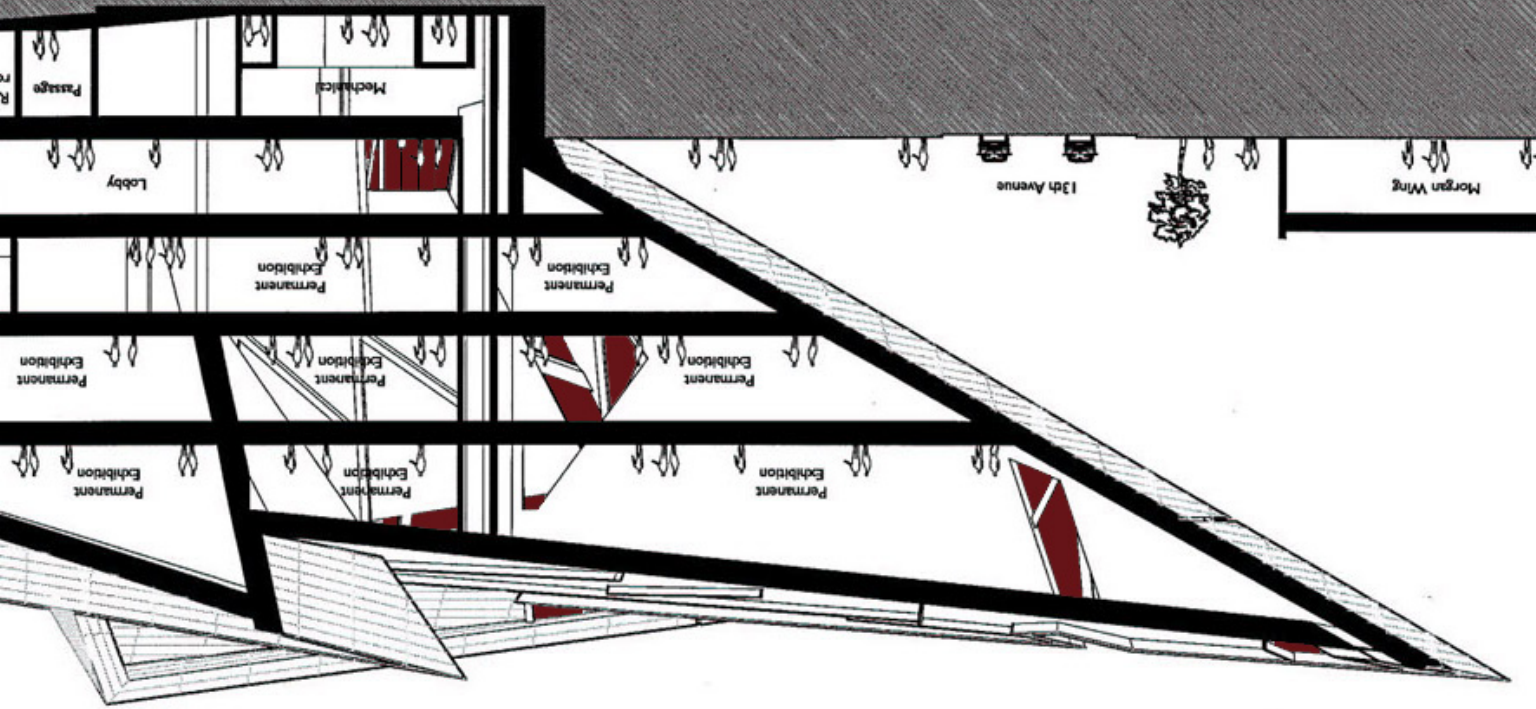


Figure 5.24 <http://www.archdaily.com/80309/denver-art-museum-daniel-libeskind/>



STRUCTURE

The building uses a triangulated frame structure throughout which is a well braced system against all forces. The main downfall to the system is that it is likely overbuilt to resist major wind and snow loads. The frame is braced in many places using the K-braced system. Using this system, the building is much more flexible under the uneven loading it is bound to receive because of its geometry.



Figure 5. 30 <http://denver13fa.files.wordpress.com/2013/09/denver-art-museum-1>

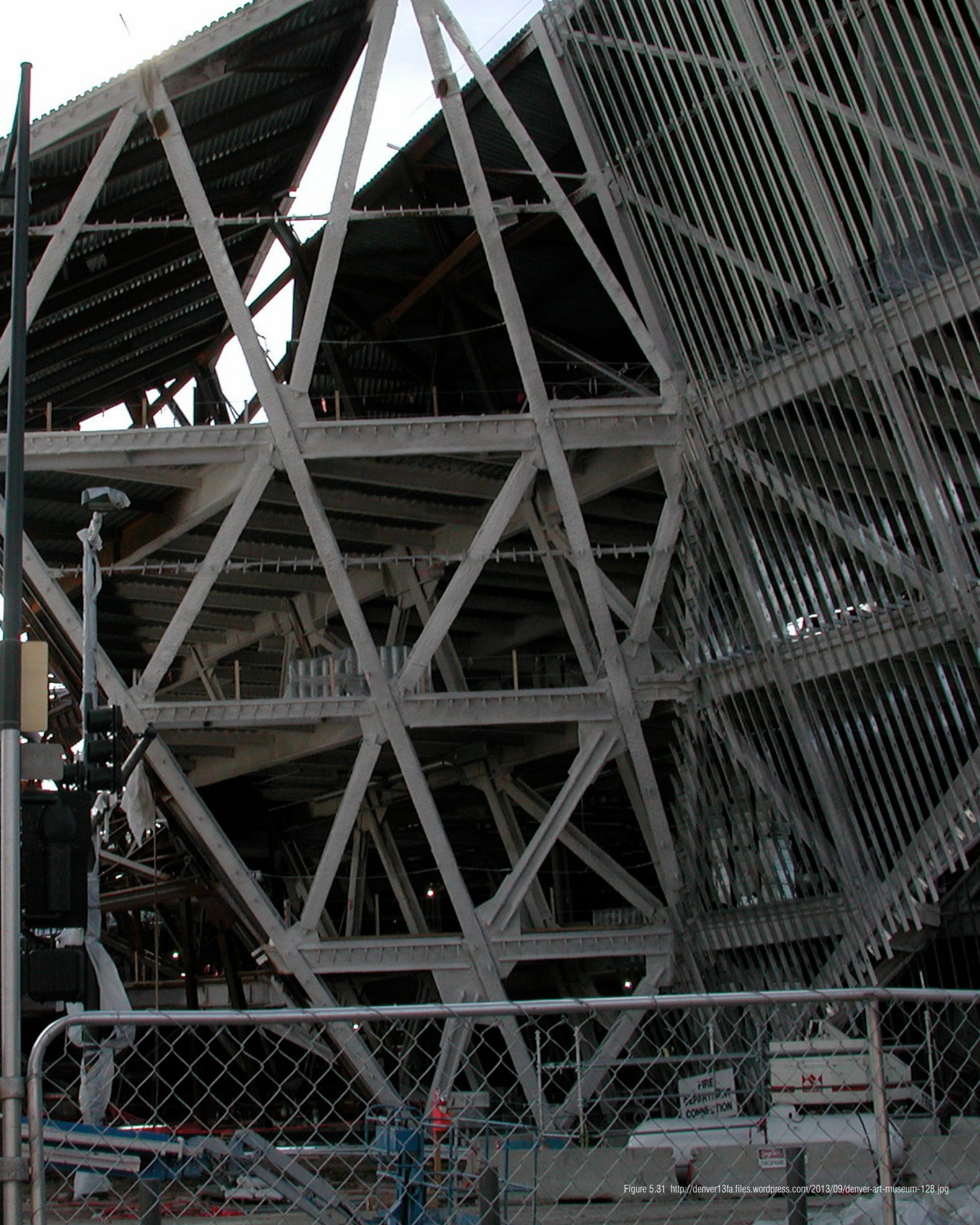


Figure 5.31 <http://denver13fa.files.wordpress.com/2013/09/denver-art-museum-128.jpg>

NATIONAL RENEWABLE ENERGY LABORATORY

SmithGroupJJR / RNL

Golden, Colorado

The National Renewable Energy Laboratory or NREL for short is a cutting edge sustainable laboratory which is blazing the trail in renewable resource research. The laboratory houses the leading research teams for all types of sustainable technologies from wind, solar, hydrogen, and biofuels. The campus houses over 2000 employees, and spans over 600 acres in the city of Golden, Colorado which is around half way between Denver and Georgetown.

Though the project is much larger than the thesis, there are many cutting edge sustainable techniques which were specific to the building and site that are being considered for use in the thesis project. The building's close proximity to the thesis site is also very relevant when considering which sustainable practices work in the region. This being said, it is my critique of the systems integration in a building such as this that drives the thesis forward. I think it was proper for the specific typology, but not many others.

STATISTICS

Smith Group Building
182,500 SF Research Building
Net Zero Building
Lobby
14 Laboratories
Offices
Insight & Data Center
Conference Space
Outdoor Test Areas



Figure 5.32 Photo of the interior laboratory space depicting how the systems are integrated into the building. <http://www.archdaily.com/443969/national-renewable-energy-laboratory-smithgroupjlr/>

SUSTAINABLE STRATEGIES

The building uses solar chimneys throughout to keep a natural convection of air flow through the spaces.

The solar chimneys also allow for daylight harvesting by using reflective materials so the light delves deeper into the space

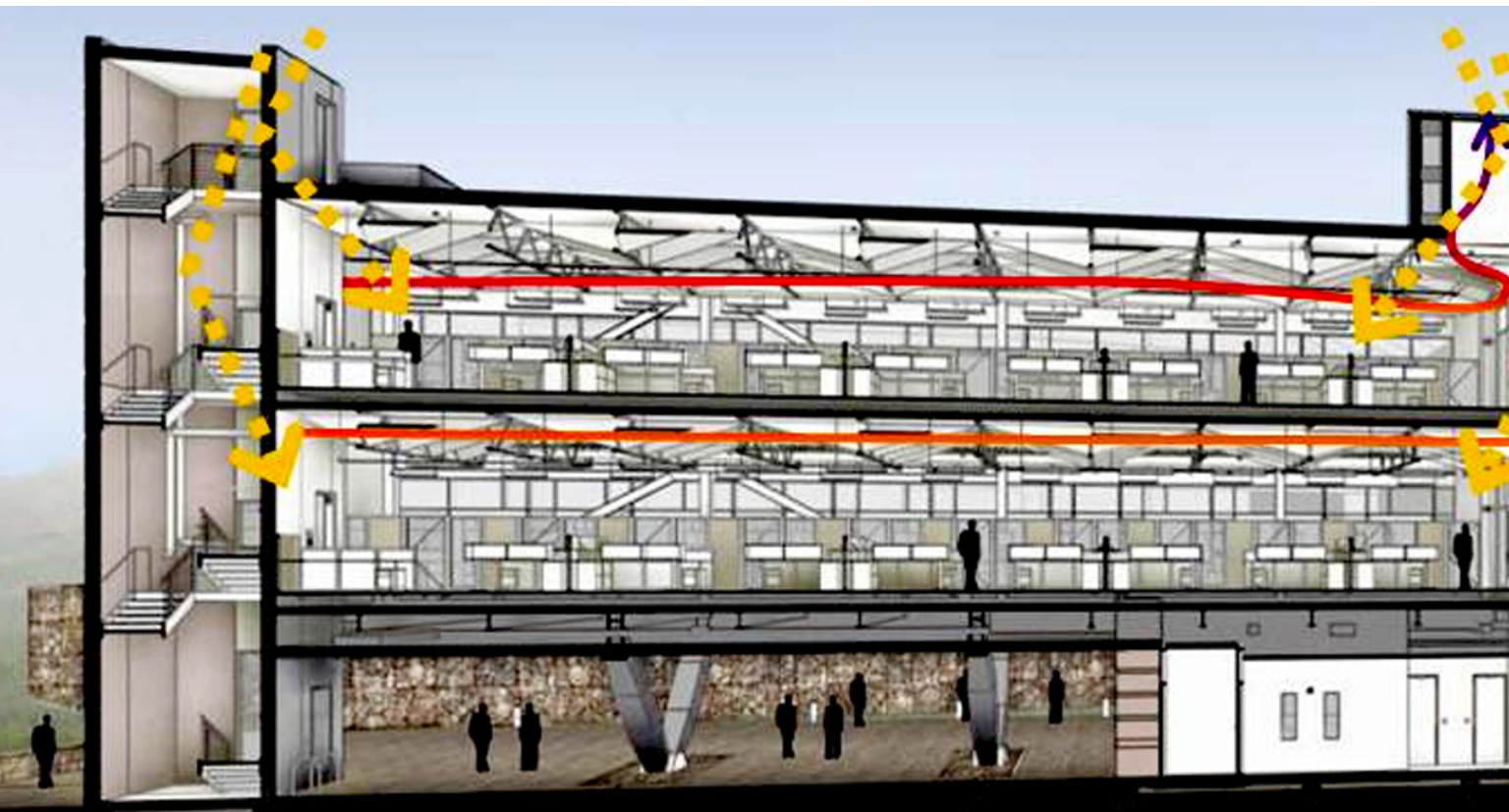


Figure 5.33 Section through the offices. <http://www.archdaily.com/443969/national-renewable-energy-laboratory-smithgroupjpr/>

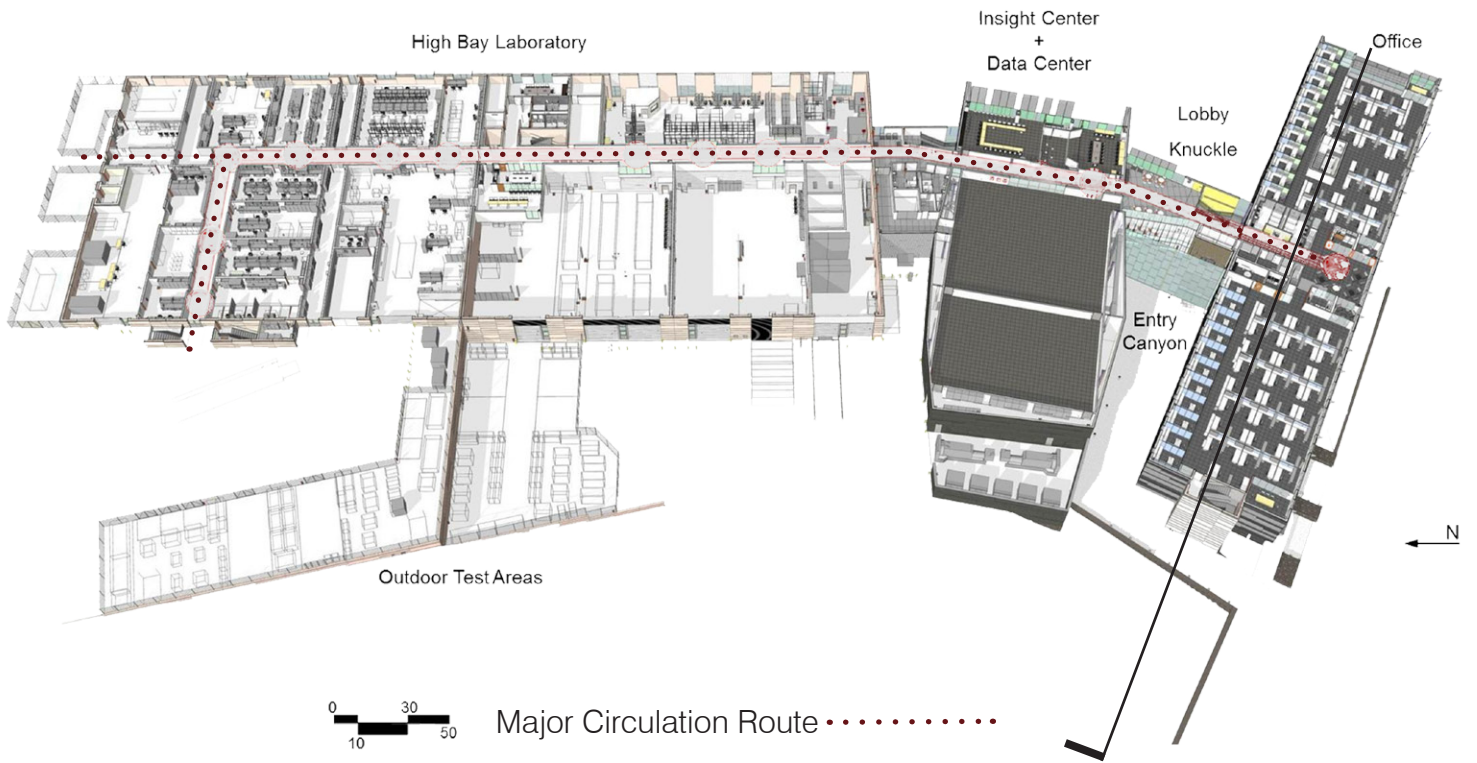
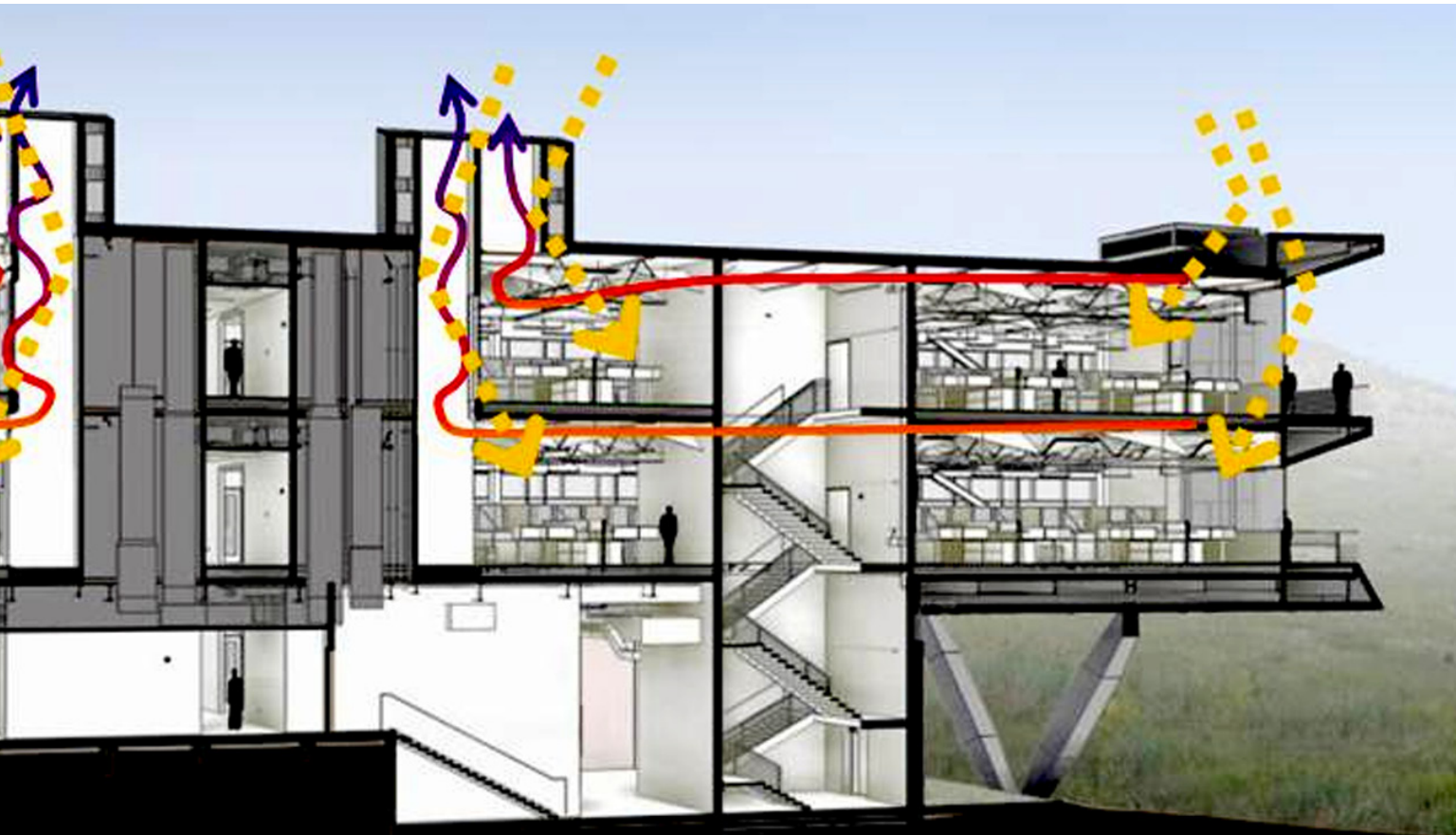


Figure 5.34 Plan of the laboratory. <http://www.archdaily.com/443969/national-renewable-energy-laboratory-smithgroupjjr/>



SUSTAINABLE STRATEGIES

Some of the technologies used in the building are as follows:

Solar Chimneys

Photovoltaic Cells

Wind Energy Generation

High Performance Data Center
Heats Building - 81% Reduction in
Energy Requirements

Light Louver System Reflects
Daylighting To Ceiling

Thermal Mass

Labyrinth Thermal Storage

Triple Glazed Windows

Double Skin Glazing

Electrochromic Windows

Radiant Heating and Cooling

Fully Automated Ventilation
System Responds to Occupancy

Natural Gas Piping

Local Materials

(http://www.nrel.gov/sustainable_nrel/pdfs/51124.pdf)

SOLAR CHIMNEYS

DOUBLE SKIN GLASS SYSTEM

STRUCTURAL SYSTEM

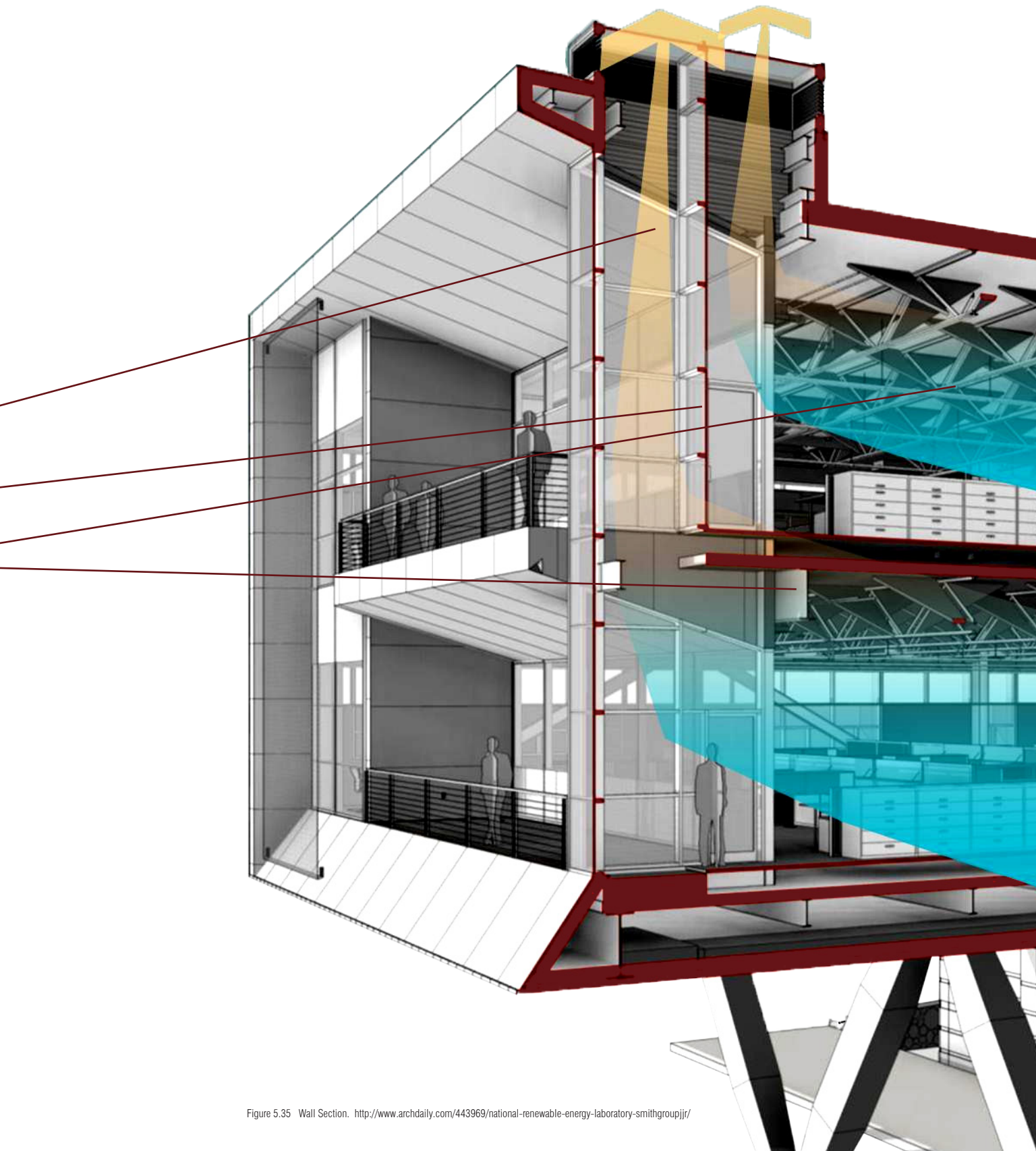
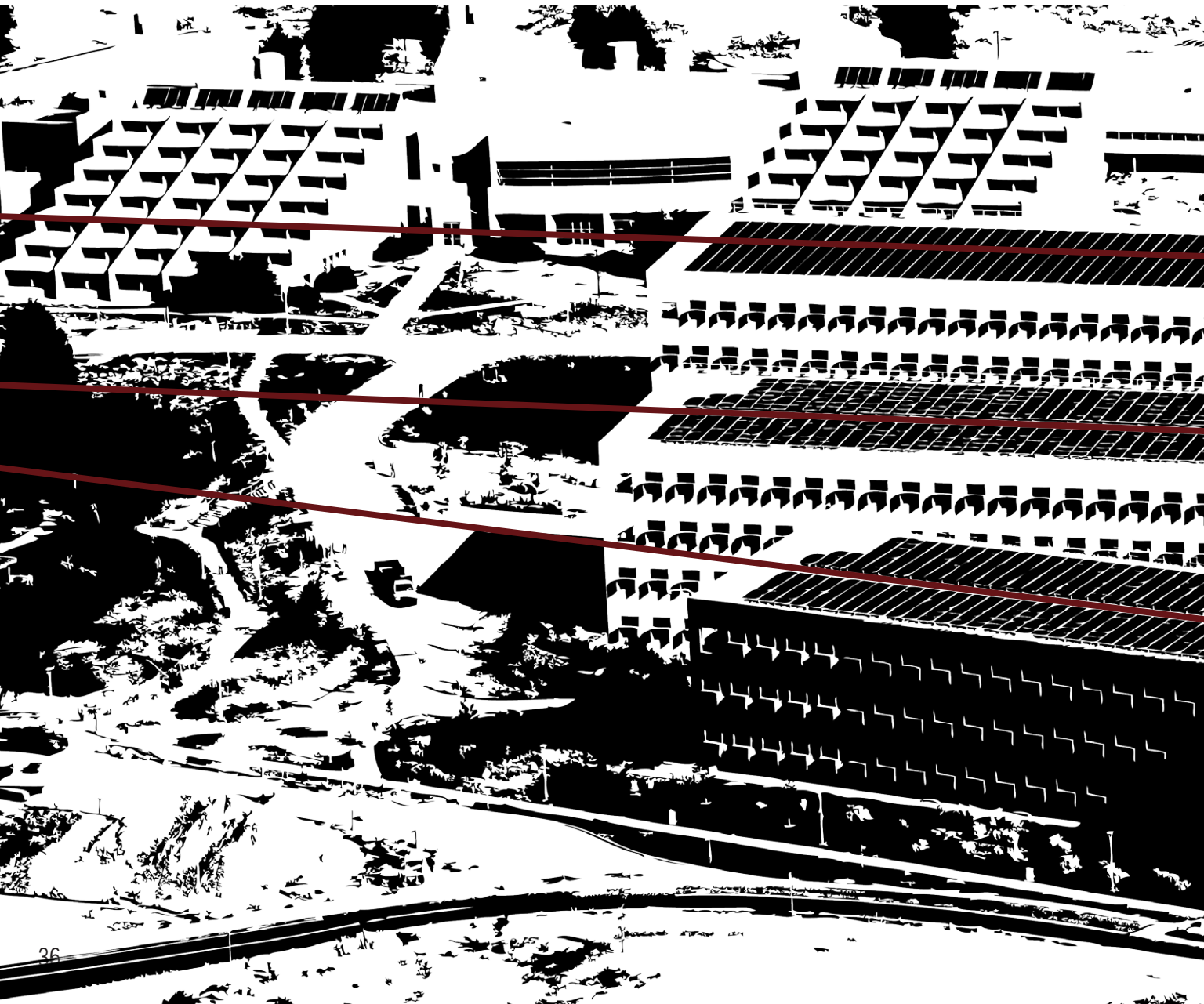


Figure 5.35 Wall Section. <http://www.archdaily.com/443969/national-renewable-energy-laboratory-smithgroupjir/>

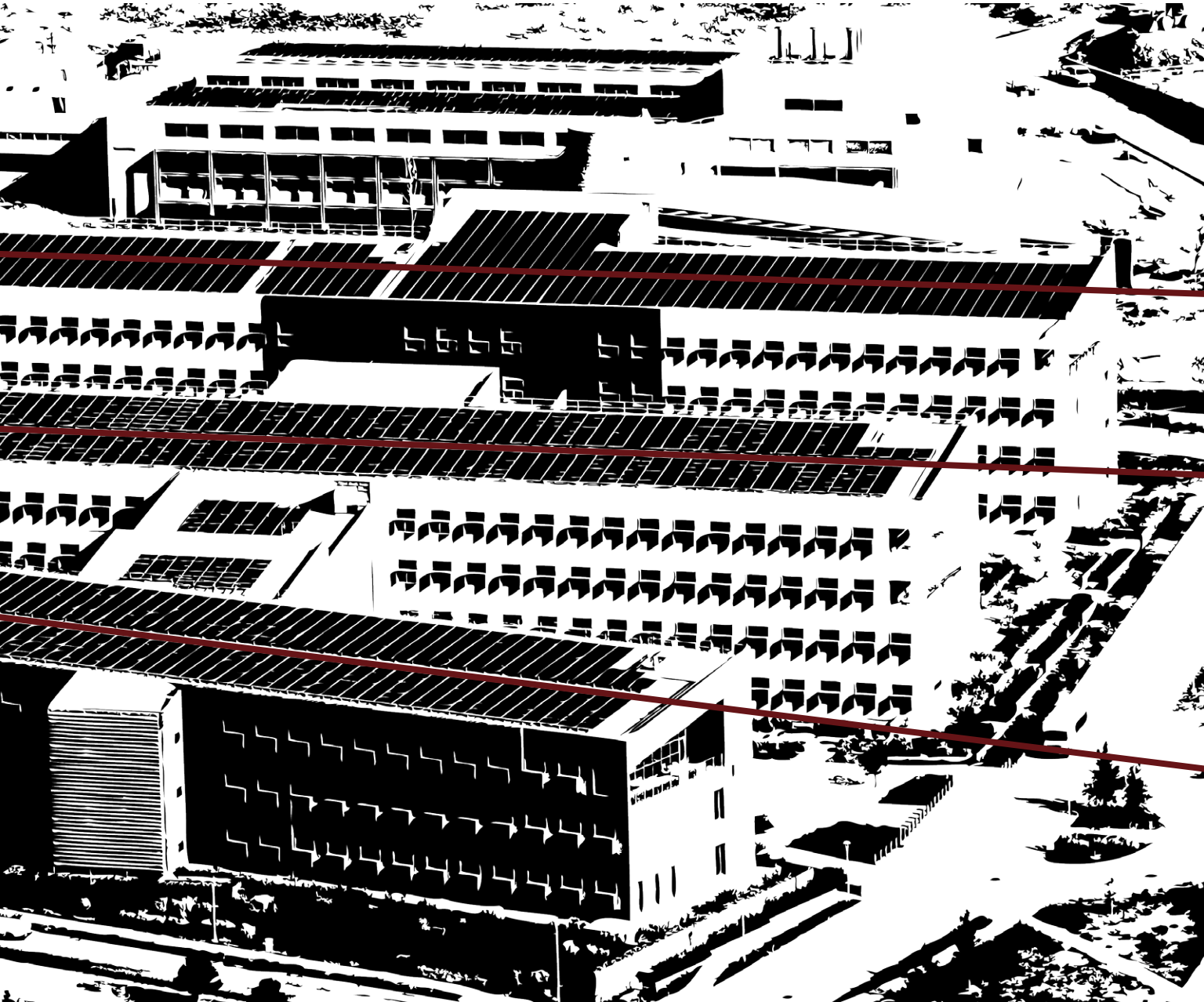
This image shows the geometrical relationships of the buildings to one another. Through difference in form, each building can be given a certain amount of hierarchy. The windows (largely in black) are situated in such a way that the building can be lit largely by natural day lighting. The shadows around the windows are generated by a louver system which is designed around the sun's path.



The axes of solar orientation allow for much of the building - including interior courtyards between - to receive natural daylight.

Axes of solar orientation

Figure 5.41 A "Figure Ground Perspective" highlighting the geometry and lighting strategies of the building.



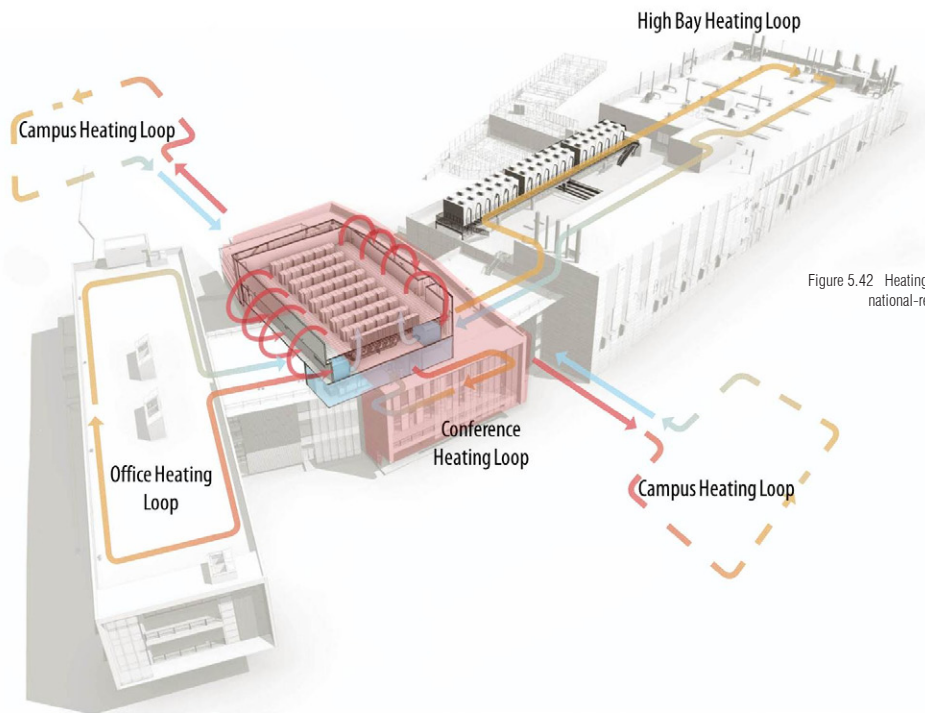
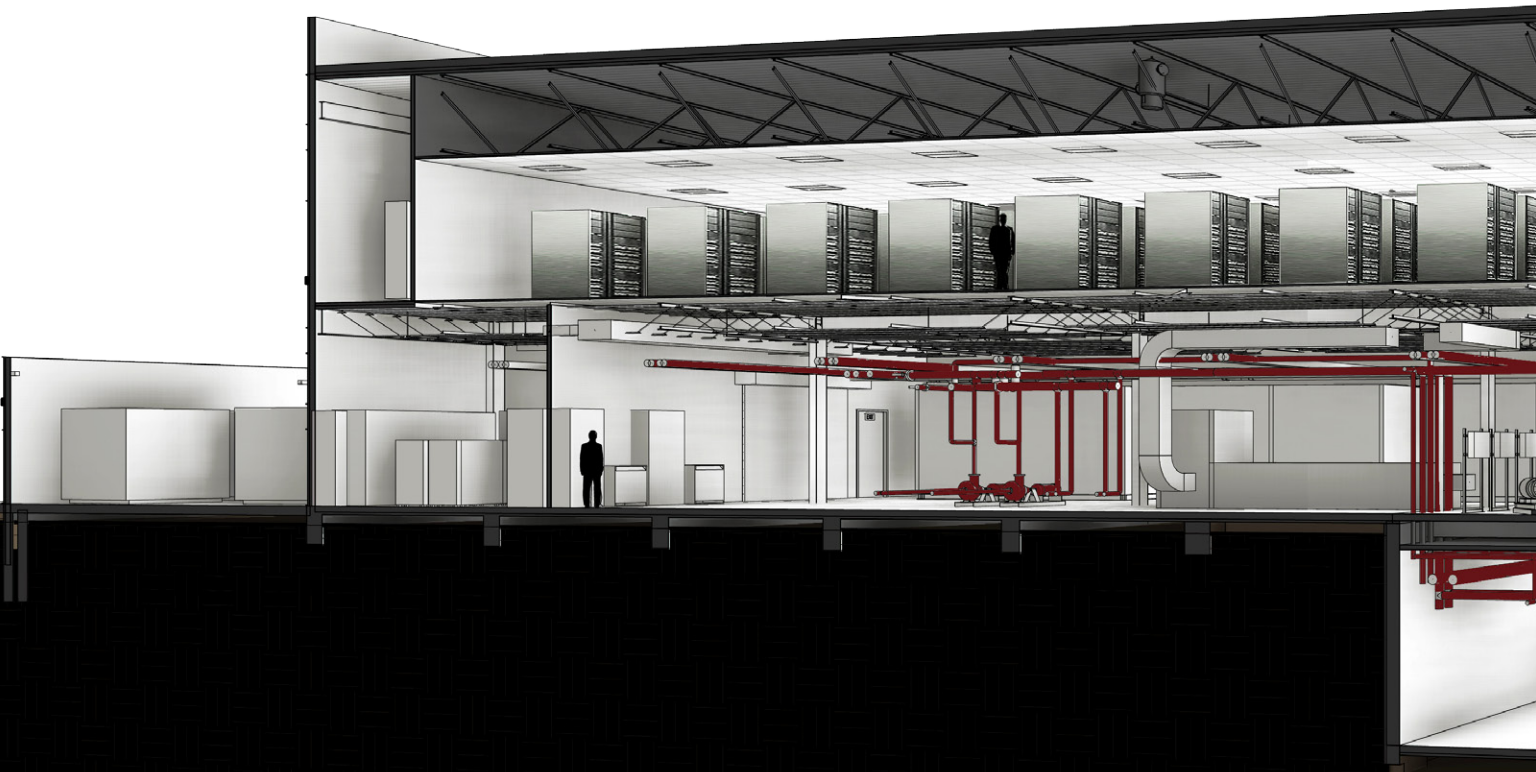


Figure 5.42 Heating loop. <http://www.archdaily.com/443969/national-renewable-energy-laboratory-smithgroupjir/>



The centrally located data center uses a special water based cooling system which is unique to the building. Most data centers use large cooling towers to cool air and pump it through the room through forced convection, allowing it to escape through the other side. NREL uses a warm water cooling system which is pumped directly through the server racks using a series of pipes to exchange the heat from the 150 degree serves to the water, which exits the room at around 95 degrees. The exchange water is then used as the primary heating source for the office, conference, and laboratory wings of the building. (<http://www.enterprisenetworkingplanet.com/datacenter/department-of-energy-using-warm-water-to-cool-data-center.html>)



Figure 5.43 Server heating section. <http://www.enterprisenetworkingplanet.com/datacenter/department-of-energy-using-warm-water-to-cool-data-center.html>

RODEN CRATER

James Turrell

Flagstaff, Arizona

Roden Crater is the remnant of a volcano which went inactive nearly 400,000 years ago. It is now the host to James Turrell's land art project which is a series of buildings that highlight celestial events. The crater has no telescope, but rather a naked-eye observatory which is made possible through various oculi scattered around the installation. The installation highlights many celestial events which are unique to the site, such as Solstices, Lunar Standstills, and cycles of stars. One of Turrell's major inspirations for the project was the idea of feeling light. In the Arizona desert, an oculus and lingering dust is a combination for an amazing light show.

The unique location of the site as well as its solitude were obviously major draws for Turrell. Through taking advantage of these traits, the space transcends perspectival capture. Snapshots of fragments of space are all that can be captured by the lens of a camera when within the space. Taking advantage of the long tunnels between the installations, Turrell played with perspective by doing things such as turning circles into ovals as one meanders through the tunnels, or creating pinhole lenses to capture light upon the floors and walls of the space.

Statistics

Installation of 16 underground spaces around 200 SF
connected by a series of underground tunnels.

Naked Eye Observatory

Sun and Moon Rooms

"Crater's Eye Oculus"

Entrance Portals

Solstice Rooms

Tea Room

11-9-83

80% - 1" = 1000'

RODEN CRATER

1

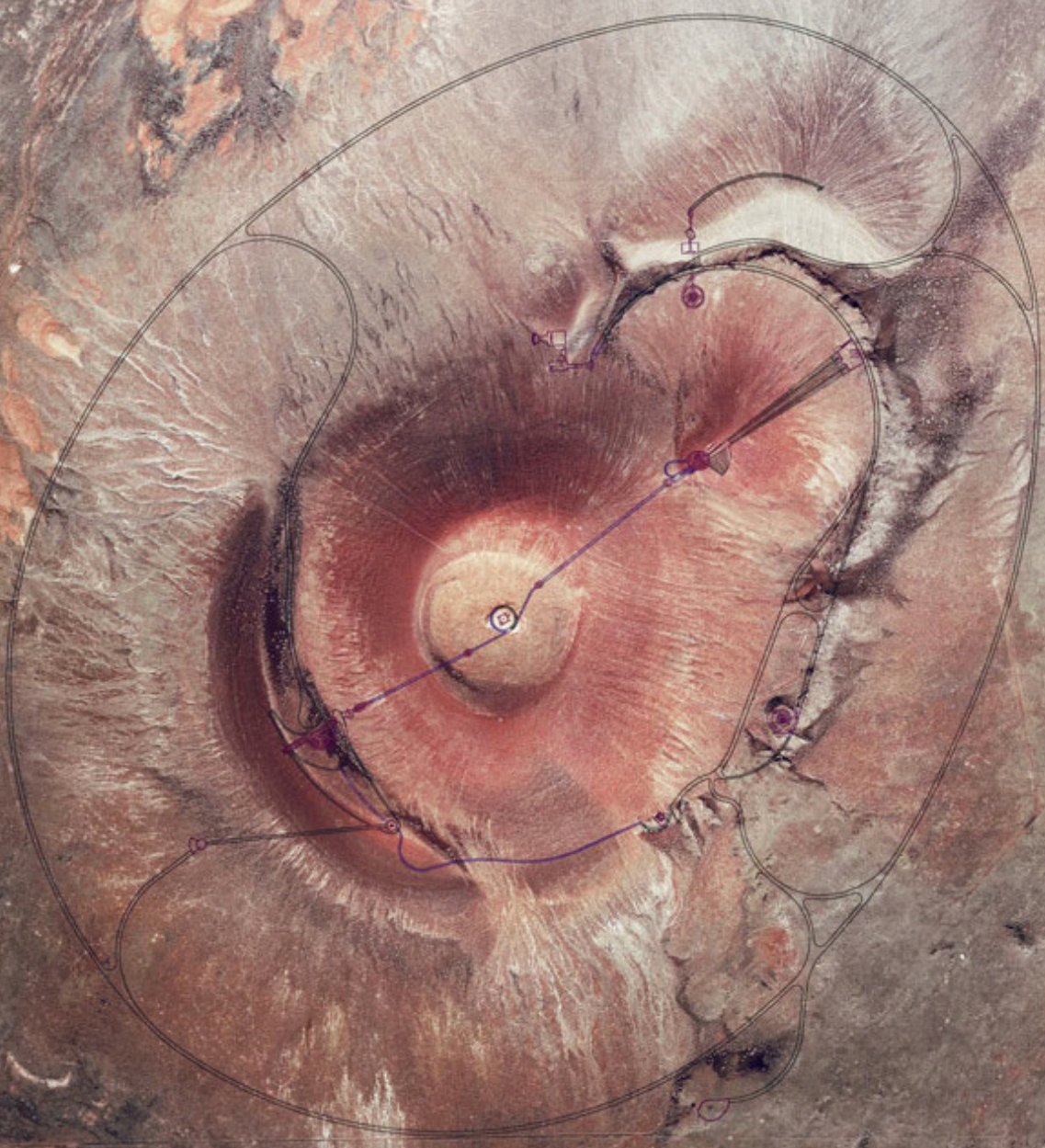


Figure 5.44 Overall Site Plan. <http://theedlist.com/wiki-2-19-879-606-201931-view-turrell-james-1-profile-turrell-james-roden-crater-project.html>

9 1 19

N 13060 152.07



Figure 5.45 Night Oculus. <http://jamesturrell.com/roden-crater/roden-crater/map-chambers/crater-eye-plaza/>

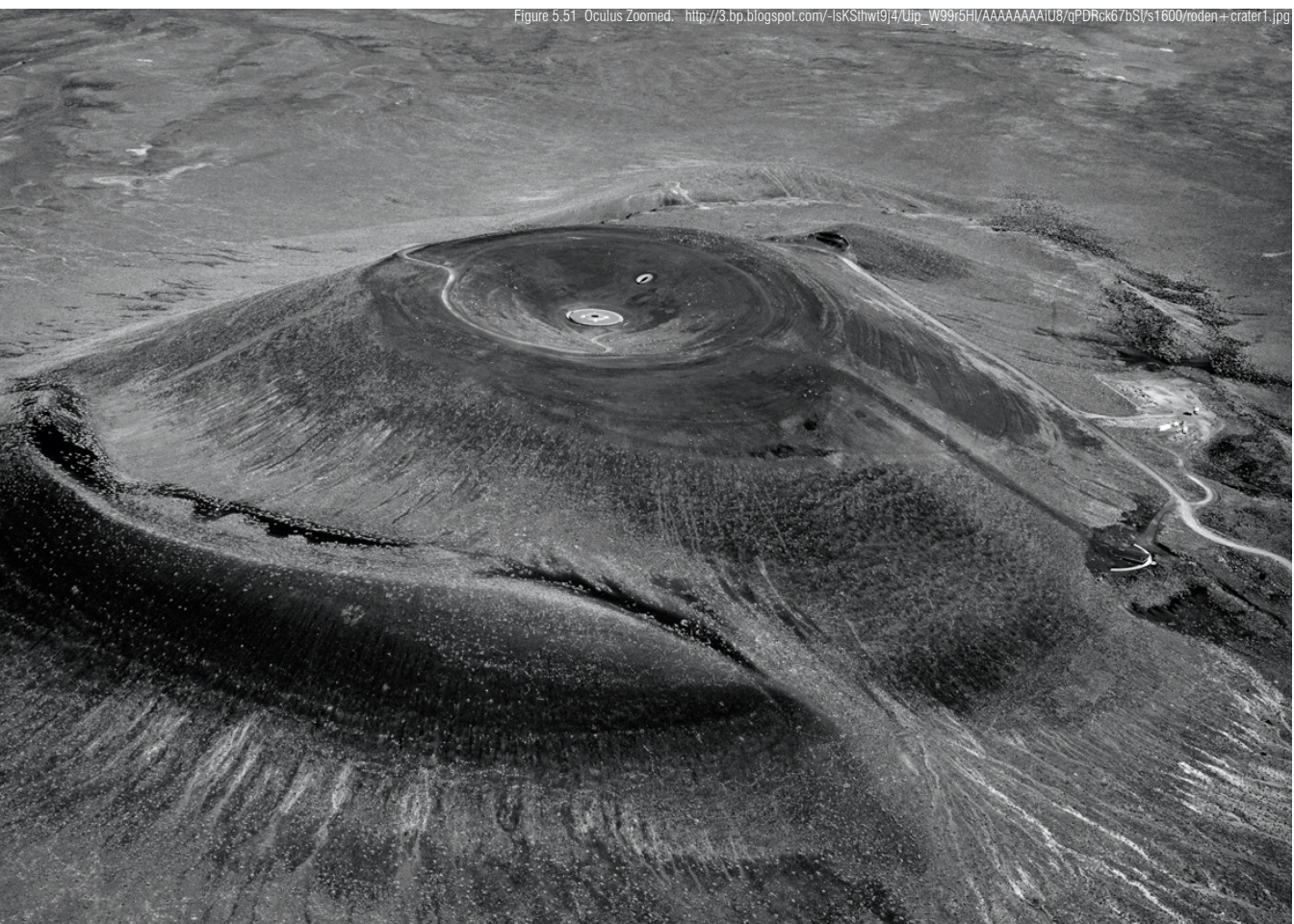


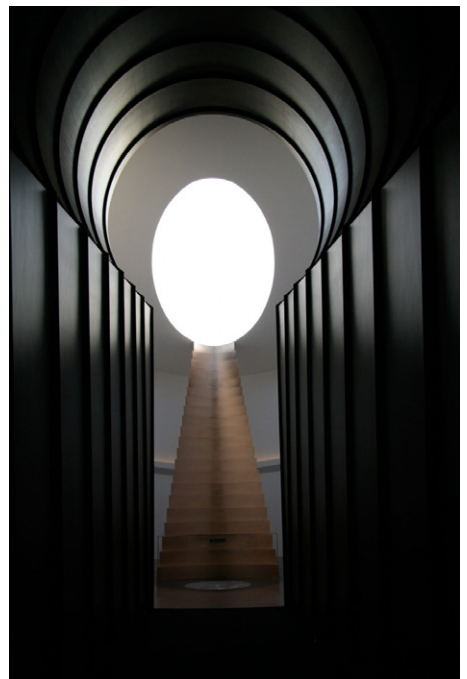
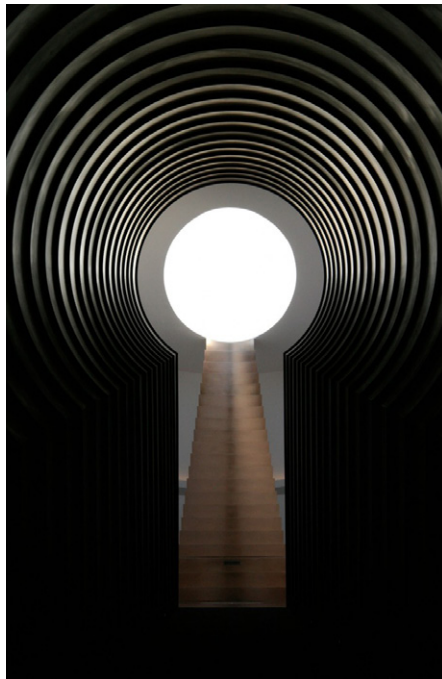
Figure 5.51 Oculus Zoomed. http://3.bp.blogspot.com/-IskSihwi9J4/Uip_W99r5HI/AAAAAAAAIU8/qPDRck67bSI/s1600/roden+crater1.jpg



The Oculus may be one of the most effective tools in historical cosmology. Allowing people for centuries to view celestial events in a new way, and study track the movement of the cosmos.

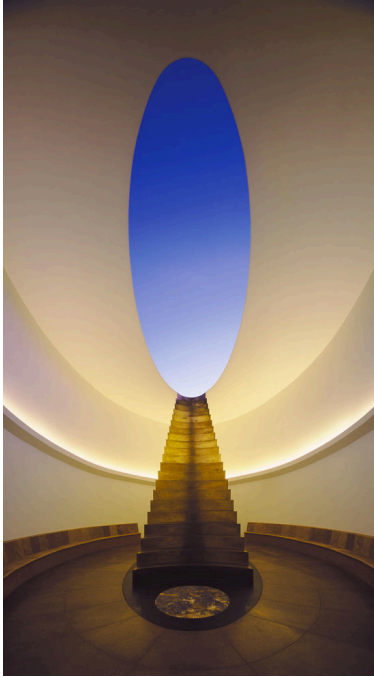
The thesis could incorporate some sort of oculus which lights up artifacts in a profound manner.

The idea of delving underground is also a strong reference to the excavation of precious gems and metals.



Above: Figure 5.53 <http://theredlist.com/wiki-2-19-879-606-201931-view-turrell-james-1-profile-turrell-james-rodan-crater-project.html>
Top Middle: Figure 5.54 <http://jamesturrell.com/rodan-crater/rodan-crater/map-chambers/alpha-east-tunnel/>
Top Right: Figure 5.55 <http://jamesturrell.com/rodan-crater/rodan-crater/map-chambers/alpha-east-tunnel/>
Right: Figure 5.61 <https://moonchildmindy.files.wordpress.com/2013/11/e-portal3-photo-by-florian-holzherr.jpg>





Right: Figure 5.62 <https://moonchildmindy.wordpress.com/tag/roden-crater/>
Left: Figure 6.63 <https://moonchildmindy.wordpress.com/tag/roden-crater/roden-crater/>

The East entrance of the installation emphasizes a warped perspective when approaching. From a distance, it is perceived as a perfect circle at the end of a long tunnel representing the sun or moon depending on the time of day. When getting closer though, it warps into a very expressive oval form. At this junction, Turrell symbolizes a climb up into the unending heavens. A warped perspective is a powerful symbol in the experience of the space. By being surprised by the space as it unfolds before oneself, one tends to ponder deeper into the very roots of their own perception.

The interesting notion of the warped perspective can be embodied in the thesis as well. A phenomenological tool at its roots, it questions reality in a way that oftentimes will get people thinking.

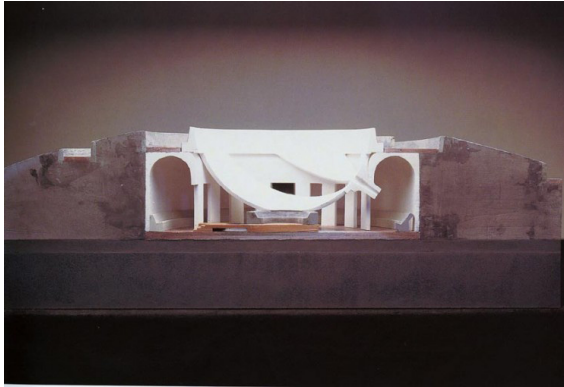


Figure 5.64 Cross section model of the naked-eye observatory.
http://jamesturrell.com/wp-content/uploads/2013/05/rc_south_space_model_1-745x509.jpg

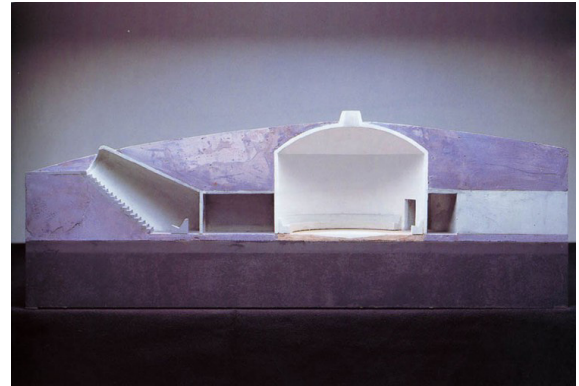


Figure 5.65 Cross section model of the pinhole celestial camera.
<http://jamesturrell.com/roden-crater/roden-crater/map-chambers/north-space/>

These cross-sections show some of the spaces in the installation. The naked eye observatory, shown top left and right, is one of the main tools for viewing celestial events. Many of the other spaces are designed for once-a-year occurrences such as equinoxes and lunar standstills. The pinhole camera is one of the most interesting spaces in my opinion. The single beam of light allowed into the room by the pinhole travels throughout the day around the room in a very phenomenal manner, and at night - presents the stars at one's feet.



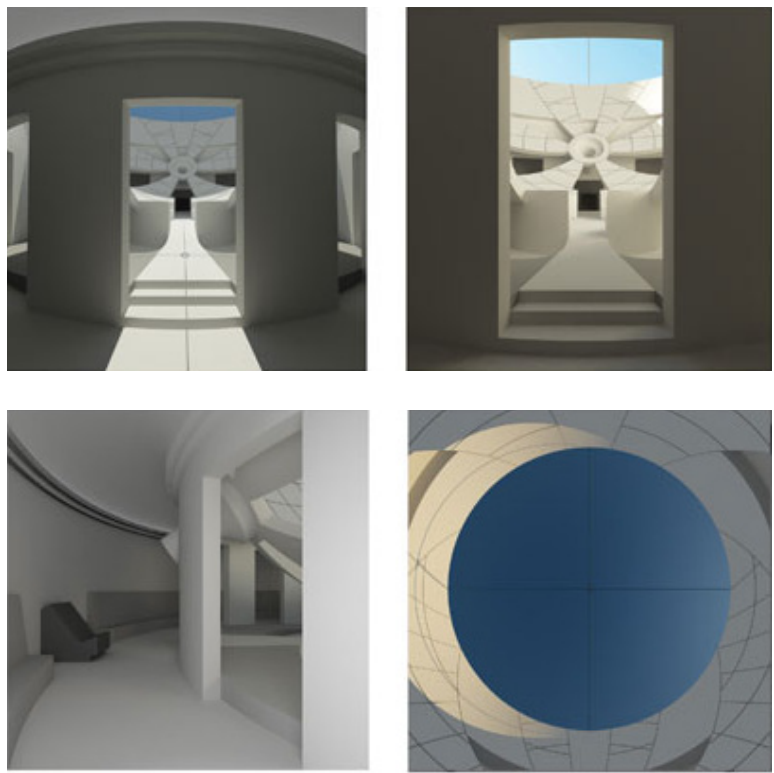


Figure 5.71 Details of the naked-eye observatory. <http://roden crater.com/friends>



Figure 5.72 Cross section model of the moon space. <http://jamesturrell.com/roden-crater/roden-crater/map-chambers/north-moon-space/>



Figure 5.73 Cross section model of North space. <http://jamesturrell.com/roden-crater/roden-crater/map-chambers/north-moon-space/>

Summary of the Typological Research

The series of case studies executed were chosen for each of their unique relations to the unifying idea of the thesis. The first study, the Denver Art Museum, being a similar program and possibly similar size of the thesis was an easily relatable choice. The study was also chosen for its reference to local culture and close proximity to the thesis site. It is an outstanding example of the building program which directly affected the program of the thesis. The labyrinth qualities of the building are also directly relatable to the historical contextualization relation which is part of the unifying idea.

The second study, the National Renewable Energy Laboratory, was directly related to the sustainability aspects of the thesis' unifying idea. Being one of the most relevant sustainable buildings of today, and being in close proximity to the thesis site allowed for direct analysis of sustainable technologies that are relevant in the locale.

The third study, Roden Crater is an example of a site-specific installation which I believe is very harmonious to historic culture, which engages one of the final unifying ideas of the thesis. Being very different from the other two studies, the installation spoke to a different cultural dialogue. The other studies being very modern interpretations of culture, Roden Crater, though a recent project, is seemingly as timeless as Stonehenge or the Pantheon in its context. Using ancient Indian technology, the naked-eye observatory, Turrell evoked very unique perceptual experiences which are revealing in their cultural context. The ritual behind the installation is something which can possibly be integrated into the thesis. Not only that, but the idea of delving underground in a sort of excavation of the earth is directly related to the program of the thesis, being a museum of rare gems, metals & minerals.

The Denver Art museum by Daniel Libeskind is a unique structure which transcends the ideas of many architects who believe form follows function, or vice versa. Libeskind proves through his origami-like building that an expressive outside can be reflected as an interior experience in a meaningful and relatable way. The case study relates to the NREL building in that it's size is similar, and it uses similar new-age materials.

Though it's layout and function somewhat detached. It relates to Roden Crater in that they are both poetically pointing somewhere. The Libeskind building- the greater culture of the Denver area, and Roden Crater- to the cosmos beyond. The cosmos and culture are both linked in a deep rooted historical reciprocity. Heidegger would relate these things, as in *Building Dwelling Thinking*, as two parts of the fourfold - the heavens and the divinities. (Heidegger, 1971) The true divinity in the case of architecture is the culture that surrounds it and lives on indefinitely. The sustainable aspects of the NREL building are being integrated into a cultural relation similar to these ideas. By informing the public of it's intent, sustainability will ultimately become a cultural norm and live on indefinitely as well.

The museum is also related to the Roden Crater in its use of labyrinth-like perceptual space. Though done in two different ways, the buildings are always disorienting the user only to re-orient through view or form.

Conclusively, the circulation of the Denver Art Museum, as well as lighting techniques and program are of the utmost relevance to the thesis program. The small nuances in lighting and shadow can be related by similar means, but in a totally new way to create something which relates to culture, all the while disorienting and stunning the users of the space.



Figure 5.74 <http://www.archdaily.com/80309/denver-art-museum-daniel-libeskind>



Figure 5.75 <https://hpc.nrel.gov/press/files/lab-of-the-year>

The National Renewable Energy Laboratory (NREL) is a campus which is so cutting edge in its sustainable systems, it almost seems futuristic in nature. The main lab designed by SmithGroupJJR is an example of sustainable systems which are unprecedented in their application. Through the design of the building, one can start to read through the systems and realize how they are working on an individual basis. One can notice, though, how the systems could be integrated in a more evocative expression, allowing a dialogue to develop between the users of the space and the systems themselves. This is one of the main goals of the thesis.

NREL is very different in scale, users, and program from the other case studies, which is why it was chosen. Though the scale of the thesis is vastly different than the scale of the campus, an analysis of the integrated technologies proved to be very useful when considering technologies to be taken advantage of in the museum. The close proximity of the building was also one of the major drives for the case study. NREL is only around a half-hour drive from Georgetown, therefore any sustainable practices used in the case study will be as relevant (site forgiving) in the museum.



Figure 5.81 <http://blog.csfineartscenter.org/2012/07/5-ws-of-james-turrells-roden-crater.html>

Roden Crater is a very unique site-specific installation in the Arizona desert. Through the delving underground of its large interconnected campus, the experience allows for an unprecedented allowance of seclusion and ritualistic reflection. Conducted by the gifted hands of James Turrell, the buildings speak to culture through very historically relevant, and contextual dialogue. Based on the condensed perception of the cosmos, the installation reveals the rituals of the heavens in a non-technological way. This is why it was chosen as a case study. The use of local materials, the human body, and nearly no modern technology allows the installation to speak to the roots of the human perceptual experience.

Roden Crater is very different in scale, program, and technology to the other studies. That being said, it can be related to the Denver Art museum in that it is like a museum for the cosmos. As earlier stated, the labyrinth-like qualities of both places can also relate to one another. It could also be related to NREL because it takes advantage of natural light and has no carbon footprint aside from a generator to power James Turrell's residence nearby. Through its location and using age-old technologies, such as the oculus, pinhole camera, and a naked-eye observatory, the installation takes advantage of light in a historically significant manner. Highlighting some of these technologies in the thesis design is very important because the way that gems and minerals are lit has a huge affect on their perception.

Major Project Elements

Integration of Sustainable Strategies in a Human Way

Passage and Entrance Exhibition Space

Break-Out Exhibition Spaces

Flex Conference Space

Underground Parking

Cleansing Spaces

Security Room

Loading Dock

Art Storage

Auditorium

Workshop

Retail

Café

User/Client Description

Clients

The project clients are a series of private investors, collectors, as well as government funded educational grants. The owners of the project are people who dwell in Georgetown, and have taken an interest in making opportunities for the town to grow in popularity.

Geology Enthusiasts

The end users of the space who make the place a destination instead of stumbling upon it by chance or passing by. They are specialists in the field who wish to review the prime examples of their research and interests.

Education Associated Users

Education related field trips, research, and tourists who wish to gain further knowledge of geology, site specific integration, or sustainable building practices. Likely to arrive in large groups, these users represent the peak load of the museum.

Curious Observers

The local and regional dwellers of the area who have either heard through word of mouth or advertising of the place's existence. People who are grid-locked in the Interstate transit system who stop through out of curiosity en route to another destination.

The Project Emphasis

The concept is to create a sustainable museum which relates sustainable practices in an experiential and meaningful way to the general public. This is done by using the technologies in a way which may seem irregular to the specialist, but more relevant to the common observer. By so doing the goal is to inform and provoke deeper thought into sustainable lifestyles. Secondly, the project will question and contextualize the historical roots of the use of gems and other materials for cultural expression, symbolism, and trade. Through the design of a sustainable museum of gems, metals & minerals, the thesis hopes to capture the cultural history of the site Georgetown, Colorado and inspire passerby to explore the museum and the city in which it dwells.

Goals of the Thesis Project

The thesis aims to bring social context into a field which is currently in the realm of the specialist. Sustainability is currently a topic which is often viewed from an objective scientific perspective of applying a formula by using different technologies, and receiving an objective output of quantified data. The premise of the thesis is that these same things can be done in a way which is apparent to the users of the building without having to consult a specialist as to how it is done. By integrating sustainable practices in a holistic way through the entirety of the design instead of designing a building and later adding technologies may have more of an impact upon the perceptions of the place by the end user. This is to be done not only through applying the technology, but also pointing users to a cultural context which is greater than the building itself. This is something that is often not done in architecture anymore, so I believe that it should be pursued. The ultimate goal is to provide insight into the technology through a greater cultural context therefore allowing the users of the building to reflect on how sustainable practice is integrated into their personal experience.

THE ACADEMIC

The thesis has been produced to fulfill the requirements of the fifth year masters program in architecture at North Dakota State University. Upon completion, I will be rewarded with a Masters of Architecture degree, which is my current goal for architectural education. The topic was chosen because it is and will be relevant in the field of architecture for a nearly indefinite amount of time so long as society continues to burn fossil fuels and coal for energy production. My end goal is to provide a greater context to colleagues and peers when integrating sustainable design.

THE PROFESSIONAL

Upon graduation, I plan to seek out a firm which practices design in a way that responds to the greater context and culture beyond pushing out the next building. I am interested in doing social projects such as museums, theaters, and government related cultural centers. I hope that the thesis will be the final reference which can be looked at as the entirety of my personal knowledge and skill accrued from five years of architectural study. I hope that the results of the research will be seen as relevant and outstanding among my peers and professional colleagues.

THE PERSONAL

Contrary to many young architects, architecture hadn't been a passion of mine until I assimilated into the higher education system. I had always been more interested in math and science, so I had thought. After two years of engineering studies, I realized that my life was missing the expression through design which I had always craved. After switching to architecture I found my passion for design and it's integration into my personal life. I hope that the thesis will be the landmark which can claim as my personal accomplishment which colorfully shows the passion I hold for architecture and design.

Plan for Proceeding

AREAS OF RESEARCH

Areas of future research include:

Further research of sustainable technologies and their current integration techniques.

Further historical contextualization of gems, minerals, and precious metals.

Integration of Phenomenology in architecture.

Further typological research of museums.

Historical context of Coloradan culture.

Historical context of Georgetown culture.

Deep site analysis, including that of Georgetown as a whole.

Programmatic requirements for multiple museum types.

DESIGN METHODOLOGY

Design methodologies include but are not limited to:

Mixed method quantitative/qualitative analysis employed through the reading of philosophy and the study of science.

Graphic analysis of effective sustainable strategies for the local region.

Digital analysis of models, charts, and digitally generated graphs.

Analysis of phenomenological practices through historical texts and documents.

A concurrent Transformative Strategy will be employed throughout the process, allowing the theoretical premise to be implemented through quantitative and qualitative analysis.

Hierarchy will be practiced when relating the data back to the theoretical premise.

The data includes but is not limited to statistical data, scientific data, or qualitative data.

DOCUMENTATION OF FINDINGS

All data researched and recorded will be presented to the overall advisor of the thesis on a weekly basis.

The findings will be preserved in a digital format, or in a physical format of documents and drawings.

The research will then be made available through the North Dakota State University Repository for later presentation and analysis by peers and colleagues.

At the end of the thesis, a one-time digital and physical presentation will be composed and delivered to a jury of peers, professors, and advisors.

Schedule for Proceeding

Task	Days	Completion
<u>Project Documentation</u>	119	<u>05.11.2015</u>
<u>Context Analysis</u>	21	<u>02.02.2015</u>
<u>Conceptual Analysis</u>	14	<u>02.02.2015</u>
<u>Spatial Analysis</u>	7	<u>02.09.2015</u>
<u>Context Development</u>	14	<u>03.09.2015</u>
<u>Structural Development</u>	7	<u>03.09.2015</u>
<u>Digital Model Development</u>	84	<u>04.22.2015</u>
<u>Floor Plan Development</u>	21	<u>03.02.2015</u>
<u>Envelope Development</u>	14	<u>03.11.2015</u>
<u>Material Development</u>	7	<u>03.11.2015</u>
<u>Midterm Review</u>	7	<u>03.13.2015</u>
<u>Project Revisions</u>	21	<u>04.22.2015</u>
<u>Rendering</u>	14	<u>04.15.2015</u>
<u>Presentation Layout</u>	7	<u>04.22.2015</u>
<u>Plotting</u>	7	<u>04.24.2015</u>
<u>Exhibit Installation</u>	3	<u>04.27.2015</u>
<u>Thesis Exhibit</u>	20	<u>05.15.2015</u>
<u>Final Thesis Reviews</u>	8	<u>05.07.2015</u>
<u>Final Thesis Documentation</u>	1	<u>05.11.2015</u>
<u>Commencement</u>	1	<u>05.16.2015</u>

THESIS PROGRAM

Results From Theoretical Premise

THE MYTH OF SUSTAINABLE CULTURE

The myth of sustainable culture resides in the dual nature of its own definition. First it can be described as the literal - the fact that sustainability today is being presented as a nearly propagandized reality which is not actually upheld in the realm of experience, but rather in that of simple application. The second myth is that of the true connections and *mythos* that lie inherently in the definition of the word. Through the unfolding of this *mythos* through contextual dialogue one can hope to make strong enough connections to create a new and better Myth of Sustainability for the fitter, faster, and more-productive culture which we have been presented with today.

For eighty years Georgetown, Colorado was a destination for the silver seekers of the Pike's Peak gold rush commenced 1858. The city then was a much different place than the laid back natural paradise that it is seen as today. In those days people of all different temperaments, talents, and convictions were drawn to the place by their similar obsession with gold, silver, and other fortunes. For eighty years the people of the city saw the earth as a bridge to their own fortune. For eighty years the dwellers unanimously concluded that the earth should be seen as nothing but standing reserve. On the eightieth year after the town's inception it was instantaneously dissipated in the same fashion of its creation due to the lack of thought and precedent leading to its undoing, and due to the ironically illustrious greed of its founding.^[1]



Figure 20.11 Georgetown, Colorado in 1879. http://www.onlycolorado.com/Colorado_Photos/georgetown_from_above.php

Similar corollaries can be noted concerning the systems set in place in contemporary culture. The recent (as of 2014) oil boom in North Dakota can be seen as a related modern-day gold rush of yesteryear. Unsustainable population growth has led to high violent crime, drug trafficking, unstable infrastructure, and future water issues - the latter due to new specialized fracking technologies being used.^[2] Similarly to the historical precedent nearly encyclopedically provided by Georgetown, the Bakken formation in North Dakota will be quickly vacated once there is no 'standing reserve' to drive the greed of the citizens (not dwellers) who came for the sole purpose to capitalize on the objects provided by the earth. Unlike lucky Georgetown, though, North Dakota is not the scenic paradise that is required for future growth beyond that of the ghost town. I digress.

Let us break down this idea of which is the opposite of the prior discussion; let us unpack the premise of sustain-ability.

Sustain (to restrain) - ability (the means to do something) roots from the Anglo French word Sustenir (to uphold) - rooting from Latin Sustinere (to hold)^[3] - implying the bodily action of holding something with ones hands.

Inherent in the context of the word is an undeniable reference to the human body which is lost in the practice of the verb today.



The origin of sustainability was a simple thought; don't over use resources leading to your own undoing. The ever present reminder of the penalty of our own actions are the massive Moai statues of Easter Island. The thought has been looming far before their discovery, but has been ever present in the minds of the few since industrialization of culture. Martin Heidegger was not the first but certainly the most prominent figure when contextualizing the topic in the modern schema. He explained through metaphors how architecture not only engages the environment, but reveals it for what it truly is.^[4] Heidegger was the first to see dwelling within the world in terms of the fourfold. The fourfold consisting of the earth, heavens, mortals, and divinities, was Heidegger's tool for describing how we dwell in a holistic way on earth.

BUILDING, DWELLING, THINKING - MARTIN HEIDEGGER

"Mortals dwell in that they save the earth- taking the word in the old sense still known to Lessing. (Philosopher of 1700's) Saving does not only snatch something from danger. To save really means to set something free from its own presencing. To save the earth is more than to exploit it or even wear it out. Saving the earth does not master the earth and does not subjugate it, which is merely one step from spoliation"

Heidegger's views on objects, place, and being are paramount in the field of true meaningful architecture. The father of sustainability, he was the first to give many architects the tools to quantify their own choices in an inter-subjective way that both spoke to the modern cultural context, as well as the rich history of architectural discourse. Without these types of views there would be few tools to compare and contrast between architectural value beyond scientific objectification. His concepts are consequential when talking about the rich culture of architecture in the modern context.

Another of Heidegger's views which is worth highlighting for the sake of this dialogue is his idea of technology and its effect on the pertinence of phenomenology in the modern context. Heidegger argues that science has reduced all "truth" to a statistical objectification of reality. No longer is the embodied human experience relevant when determining fact due to the ease of the human mind and body being tricked. For thousands of years, science argues, humans have explained phenomena outside their realm of knowledge as magical acts of god. Therefore experience is no longer relevant. Heidegger views this as a problem because the embodied experience is how we interact with the world a vast majority of the time. One could argue that modern technology beyond the time of Heidegger has only decreased this interaction through the false reality we are now so accustomed to being presented with.^[5]



Figure 20.12 Moai statues on Easter Island.
<https://easterislandtraveling.com/images/media/images/archaeology/rano-raraku-moai-statues-tourists-1.jpg>



Figure 20.13 Martin Heidegger
http://i.telegraph.co.uk/multimedia/archive/02877/heidegger426x536_2877455a.jpg

The problem with scientific action applied to architecture that it is reduced down to an application of a process which is merely a 'formula for a successful building.' It has no relation to the human body which was the root of the definition of sustainability. Through this application, the perception of a sustainable building has become too specialized for the common user to truly understand and reflect upon how the action is actually working. It has become more a *magical* relation in so far that it is experienced as an unknown but ever powerful phenomenon.

Hans-Georg Gadamer spoke about the specialization of culture due to science in his book *The Enigma of Health*. In the book, Gadamer relates specialization to the case of the family doctor. When the doctor would at one time visit the place where people dwelled, survey his surroundings, survey the lifestyle that his patient lived, he would become enlightened further into the understanding of the patient's ailment. In modern culture, there are specialized doctors who only handle one type of treatment for many patients.^[6] The point, though, is that this same relation can be expressed in every cultural task that exists today. People are becoming ever unknowledgeable of every technology they interact with on a day to day basis. Gadamer would argue that similar to the medical field, where different specialists have no understanding of their colleagues field or even jargon that he uses, different sectors of everyday life are totally unrelatable beyond the fact that they inexplicably just work.

Specialization occurs in architecture as well. Architects often specialize in using certain materials, systems, or technologies. To even practice legitimate sustainable design, architects must go through separate training and specific certification. Even the programs used to create drawings vary greatly among different firms. The problem is not that the specialization exists - it is that the specialization is expressed in an unrealizable way through the architecture. Perhaps something is to be gained relating architecture to the senses as it classically was. Perhaps something is to be gained relating sustainability to the every day user of the space in a meaningful and *thaumatic*^[7] manner. What we learn from our perceptual experiences only becomes true experience once it is "integrated into the practical consciousness of acting human beings", Gadamer believes.^[8] This understanding of perception is subjective yet sound in that it is how people actually experience the world.



Figure 20.14 Hans-Georg Gadamer
<http://upload.wikimedia.org/wikipedia/commons/1/1d/Hans-georg-gadamer.jpg>

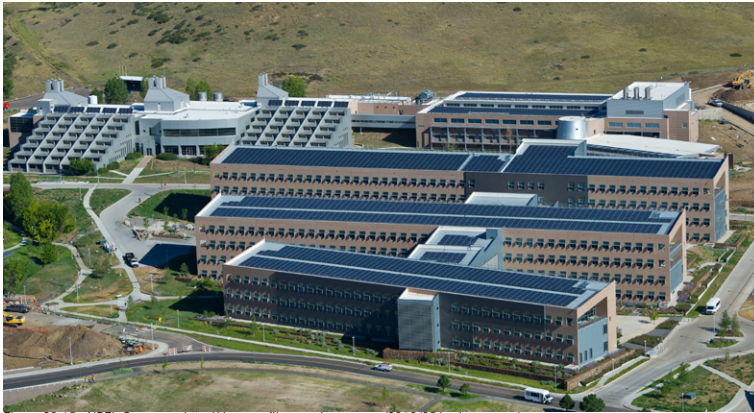


Figure 20.15 NREL Campus. <http://drpence.files.wordpress.com/2013/05/nrel-campus.jpg>

Contrarily, sustainability in architecture is presented as a technologically applied science rather than something which is integrated into the experience of the place. The application of different systems and methods as well as new energy harvesting technologies in a specialized formulaic fashion has become the definition of a sustainable building. This disconnect between perception and practice is

too specialized for the average user to interpret a full understanding of the systems and their integration into architecture. The specialization of technology has led to a 'magical' quality of existence rather than a methodological understanding of how sustainability works, and how it could be ritually integrated into our daily lives.

This ritual existence historically held a deeper relationship to cultural context than the technological views of the modern man. This was because it was relatable to the every human being in that it pertains to a bodily action rather than to scientific objectification and application. Rituals have always evoked a participation rather than an instantaneous presentation. Architecture has always been about the participation with its surroundings and the users of the space. The dialogue between the architecture and the user is truly what builds a powerful connection between the user and the perceived space.

Ritual has also always been tied to a certain depth of fantasy, or rather, imaginative context which is associated with the bodily action. Much of meaningful architecture finds its power in this fantasy it evokes through the experience. Through metaphor, it is always relating to something greater than itself. One could call this the fantasy of architecture.

"A fantasy is first and foremost, a means of stabilizing discourse. Anglo-American uses of fantasy emphasize its fictional and individual nature....[Historically a fantasy is] a collective construct that is not only publicly accessible but essential to maintain one's position in any network of symbolic relations."

-Donald Kunze^[9]

Donald Kunze uses the idea of the fantasy in his work entitled *Against Sustainability* to describe how sustainability holds a dominance over rational thought. It is impossible to be against sustainability because by saying that one is, they are instantly discredited as being illogical. The catch of it all is that sustainability is what Kunze refers to as a “dirty fantasy” in that it is preached in a nearly propagandized way. He describes the idea of a dirty fantasy in a metaphor talking about the SUV. The SUV is commercialized as the ‘safest vehicle on the road’ due to its sheer size when compared to smaller cars. The dirty fantasy is that the SUV is safe only in that it kills the other driver if you were in an accident. Similarly sustainability seduces us into thinking its about a “green” future, but the reality lies in what would happen if it wasn’t practiced.

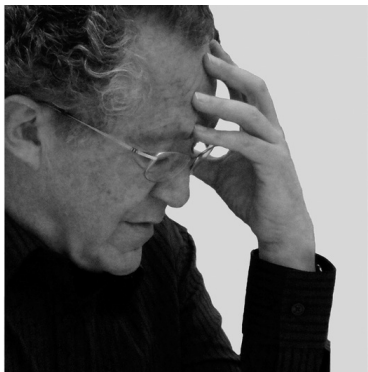


Figure 20.21 Alberto Pérez-Gómez <https://d288psc4bmi1ppz.cloudfront.net/sites/default/files/styles/onequart295w/public/newsitem/2014/05/albert-perez-gomez.jpg?itok=jEkqS1CE>

Sustainability though is far from the first use of fantasy in architecture. A relevant example of an old myth spoken in a modern tongue would be *The Myth of Daedalus* by Alberto Pérez-Gómez. In the reading Gómez speaks of how the architecture of today is overshadowed by diverse demands and complex technologies. Historically the architect’s primary duty was to engage the public realm not unlike the sculptor or painter. The architect today though should be able to acknowledge this complexity and relate to the ever important cultural relevances relating to love, desire, and compassion on which architecture is built. The key here is that it may only be acknowledged. It’s not that all architecture must be based on this *seduction*, though it is certainly present in all great works. Gómez quotes Socrates in saying that “falling in love is both madness and a revelation of the world as it really is.”^[10] One can see how great architecture does this in a similar way. A great building can really set a person back enough to take a serious look at their place in the world similar to falling in love. I believe it is at this point of thaumata that people are most accepting of observing outside stimuli and learning something from it.

“During the renaissance, love became a magical power and the architect became a magician capable of marvelous seduction.”^[11] Love in architecture can be seen most obviously during the renaissance. It was this time when architects found their power of love, or better, phenomenological control. Small facets in architecture have a substantial affect on our perception of the world.

“The architect/magus/physician is endowed with the heavenly gift of love and a keen capacity to identify beauty, a capacity that is indeed a kind of madness. To produce wonders, he must both love his work and care profoundly for the Other to whom it is addressed.”
-Alberto Pérez-Gómez

The Other to whom Architecture is addressed is often hard to define when designing a building. The Architect must not only define whom, but also reach out to the Other through the power which only he possesses. The evocation of a physical experience is the only power the architect has.

Other artifacts hold this similar quality of evocation. Mythologically, Perez-Gomez speaks of Daidala having this power.^[12] In modern culture, this seductive power can still be seen in things such as glassware or jewelry.

One could even state the case of precisely machined objects such as watches or handguns. These objects all have the unique power to change their surrounding environment; some more than others. But none more than the power architecture has. A common thread these objects all have is their precise refinement and craft. They are all admired by, as Hildegard of Bingen hypothesized in the twelfth century^[13], the fire contained within the object - The power of seduction manifested within. This interpretation has been pertinent since it's inception through modern experience in that it is about the participation between the artifact and the user through power of the artifact's evocative nature - something that architecture has always done. In Plato's theory of sight extramission, light issues from the eye instead of being received by the eye. It was thought that “vision requires three things: the interior light, exterior light, and opaque object. A process of refinement within the body creates an interior light that can be sent out from the eye to the object.” The mixing of sunlight and this interior light overcame the inherent weakness of the eye alone. The stronger the light, the better that “This unified light returns to the eye, carrying the impression of the object to the soul.”^[14] When a person encounters a powerful artifact some derivative of this participation, not literal of course, can be perceived. For millennia gems have been projectors of mystery and awe into the bodies of the people who covet them. Through the refinement of the gem, the clarity of this filtration of seduction is achieved. Through the participation of the gem and the viewer, the fire contained within is brought forth. This obviously romanticized theory of vision is arguably more relative to architecture than other proven theories because it involves a participation which has been always been present in the arts, specifically architecture.

The thesis utilizes this participation of vision and environment in the terms of gems. The participation of architecture and the user is similar to that of the participation of the user and a gem in that they both hold the power of seduction which Pérez-Gómez has noted as evoking a participation which is both wondrous and self-actualizing- profoundly revealing ones own sense of place and environmental potential. Gems truly have the power to change the environment around them similarly to architecture. Just as gems have inspired wonder within people, so has and does architecture. The myth behind gems has a large historical context which is still relevant today that can be metaphorically related to certain architectural qualities and experiences. Through this relation deeper meaning can be perceived through the experience architecture relating to culture, myth, and historical context. Through this relation and the relation of the site, the thesis hopes to expose the links between the artefact and architecture through the sustainable technology. Through this experiential linkage, the Other to whom the architecture is addressed- while in a moment of thaumata- will hopefully realize how their own actions relate to the context of sustainability, gems, and culture as well.

Gems, sustainability, and architecture are indissolubly linked into the unbreakable chain of culture, both historic and present. Revealing these connections is the endless task of the architect who unearths them. The thesis attempts to reconcile these relations into a sustainable architecture which is both technologically sufficient, and relevant to both modern and historical culture all the while delivering the thaumatic relationship to the body which the application of sustainable technology currently lacks.

Notes

1. Georgetown was founded 1858 during the gold rush and was largely vacated 80 years later in 1938 due to the mine's barren state, and the eventual scrapping of the idle mining machinery for metals for World War II.
2. The new fracking technologies being used have been used in the oil industry of Texas, USA after recovering the majority of the surface area of the region. The recent (2014) dustbowl state of Texas has been allegedly attributed to the lowering of the already -low water tables of the region due to the fracturing of the earth that horizontal hydraulic fracking technology takes advantage of.
3. Merriam-Webster defined roots of the word "Sustain". Looking at the word "hold" not to be confused with the command 'hold' as to hold back the force of arms, or the 'hold' of a castle or ship, Merriam-Webster returns "Middle English, from Old English healdan; akin to Old High German haltan to hold, and perhaps to Latin celer rapid, Greek klonos agitation."
4. The banks of a river are only revealed under the bridge which spans them. A place is only defined as a place by the artefact or architecture resting there.
5. The infinite Cartesian perspectival space presented in 3D modeling or even animated films and video games have presented humans with an unprecedented amount of false realities. Though they are still experienced through the body, the reality presented is of a nature which is ever refining to the point of supplementing our lived experience with itself. i.e. Oculus Rift and other V.R. devices.
6. i.e. A genealogist who only specializes in certain gene deformities and diseases has no idea what a genealogist of a different disease may encounter, or be able to even recognize a deformity or issue.
7. Greek word combining the ideas of "miracle" and "wondrous"
8. Gadamer, Hans-Georg. (1993) *The Enigma of Health: The Art of Healing in a Scientific Age*. Stanford University Press.
9. Kunze, D. (2011). (Why No One Can Be) Against Sustainability: Traversing the Fantasy of Sustenance and the Topology of Desire. *Chora: Intervals in the Philosophy of Architecture*. Volume 6. McGill-Queens University Press.
10. Perez-Gomez, A.(1985) *The Myth Of Daedalus*. AA Files 10:49-52 (London, England: Architectural Association).
11. The seductive nature of architecture was certainly most prominent during the Renaissance, but it certainly exists in many great works today. A couple examples one could argue would be Zumthor's Bruder Klaus, the Sagrada Familia, or Van Der Rohe's Barcelona Pavilion.
12. Daidala are artifacts such as gems, weapons, and armor - usually something wielded or worn - which hold seemingly supernatural powers due to their crafting.
13. Crow, J. *The Sacred Stones of St. Denis Chora: Intervals in the philosophy of architecture*. Volume 6. McGill-Queens University Press.
14. Lindberg, D. (1976) *Theories of Vision from Al-Kindi to Kepler*. The University of Chicago Press, LTD.

Annotative Bibliography

Full citations of references can be found at the end of this document.

The Enigma of Health

Hans-Georg Gadamer

-The specialist and the state of society metaphorically spoken through the complexity of the human body. Society has built a complex that is too specialized to be relatable to the average person, or even people who are very specialized but not in exactly the same field of study.

The World of Perception & the World of Science

Maurice Merleau-Ponty

-The world today is seen through an ocular-centric lens rather than the embodiment of perception as in the world of the past. People take things at their face value rather than seeing symbol and making connections through it. This is different from the ways people experienced the world before the perspective and science became emphasized over personal experience.

On the Relevance of Phenomenology

Dalibor Vesely

-Similarly to the Merleau-Ponty, Vesely argues that the embodiment of perception is more valuable than the simple view of the thing. Seeing and symbolic thought are very different than how it was in the past.

Building, Dwelling, Thinking

Martin Heidegger

-The fourfold and the simple oneness of holistic perception and reality. Bridge metaphor- the river's banks only reveal themselves under the bridge which spans them.

(Why No One Can Be) Against Sustainability

Donald Kunze

-The "Dirty Fantasy" that sustainable is and why it is illogical and social suicide to say something against sustainability. Sustainability practices truly through the fear of what the world will be without it.

The Question Concerning Technology

Martin Heidegger

-Modern thought has placed an emphasis on technological advancement for the sake of itself. This reduces all "truth" to a compilation of scientific analysis. No longer is perceptual experience a method of attracting knowledge. Only through science, modern thought states, can we ever hope to know anything.

The Sacred Stones of St. Denis

Jason Crow

-People once believed they could reach the afterlife through gems and other light-filtering materials. Light was thought to be literally god who bridge the distance between our terrestrial world and the celestial heavens.

Built Upon Love

Alberto Perez Gomez

-The foundations of architecture were built on ancient Greek views and connections to the gods, cosmos, and the powerful seduction of love. Similarly to love, architecture has the 'magical' or rather unexplained thumatatic power to seduce and inspire action within its participants.

The Myth of Daedalus

Alberto Perez Gomez

-The reading is about Historical Greek context concerning gems and the making of artifacts (daidala) by Daedalus, and thereafter by masons, smiths, and the common man. The fire contained within the artifacts reveals the reality they represent. Similarly to architecture, they contained the power of seduction through the experience of the artefact.

Georgetown: A Quick History

Kenneth Jessen

-The book contains maps, statistics, and stories of how Georgetown came to be, and met it's eventual dry spell in the 1930's. It also speaks of the re-naisance of culture in the 1960's and how it came to be the lively tourist destination it is today. The book holds detailed personal accounts of dramas, hardships, and triumphs the town faced since it's founding.

Summary of the Research Results

The topic of sustainability is pertinent to all modern architecture in that it is a new standard to which architecture is held. The technique is often practiced in a formulaic fashion by applying different technologies to a building. The thesis attempts to relate these often purely objective and technical practices to the body as all great architecture classically does. The word's roots from a bodily action of holding something within one's own hands. This is what has been lost; the relationship to the body.

Many great architectural and philosophic theorists would argue that we live in a very specialized society today. Nearly everything we encounter on a daily basis concerning technology is often specialized in so far that we can use it, but have truly no idea how it works. Our cars, computers, phones and machines all shrouded in a case that somehow relates to our body, whether it be a meaningful one or not.

One could argue that sustainability is practiced the same way today. Solar cells, high performance HVAC systems, photovoltaic glass, and ultra efficient cooling towers all do have their place in architectural practice but the problem is that they are never applied relative to the experience of the user. Sustainable systems are often integrated and automated in a way which conceals their operations and hides their existence. One could argue that this is how magic was classically believed to work in that it was a response derived from nearly no visible input. Poof- the room just got warmer.

Meaningful existence, though has historically resulted from a much more ritualistic experience with space. People still do interact with space this way whether they realize it or not. Lighting, shadow, sound, and temperature truly can build a relationship to deeper symbolic relations and to social and historical context. Experiencing great architecture reveals the significance of these things to the user in different levels of meaning, but it always is related to the body- that's how we experience the world.

Science would argue that architecture should be practiced in a purely objective format. Heidegger would argue that science actually denies the relevance of the body in experience since it can be so easily tricked. Sustainability has followed suit with science in that it has become purely about efficient technological application. Here in lies the problem. No longer is experience a valid means of interpreting space. The Cartesian grid has become the answer for that problem.

The thesis attempts to take what science does and relate it to something deeper. Though logical spatial and technological organization are important and are implemented through the thesis, there are deeper cultural and historical symbols which can help in relating the connections to the user. Relating symbols between the architecture and the body will hopefully inform the user of what the thesis is all about; the profound realization of one's own place in space and time, and how it is related to their own sustainable actions. Architecture unfortunately holds no key to solving sustainable issues on it's own. Relating to deeper issues beyond pleasant detailing and efficient spatial organization to the user is all the great architect can ever hope to do.

The thesis attempts to use the symbol of the gem to make this relation. The site, Georgetown Colorado, was after all founded on the pursuit of precious metals and gems. Historically gems have always been coveted for their abruptly profane power of seduction. People once thought they even held magical power. The power of the gem still today is the fire contained within. The real beauty is that they truly do hold the power to change the space around them in a similar fashion that architecture does.

The gem can be seen as a metaphor for the refinement of culture. Just as a gem goes through the long process of refining and polishing, sustainability could be seen as the tool refining architecture closer to the end of fossil fuel reliance.

The history of the site is relevant to sustainability as well. The city was founded upon looking at the earth as what Heidegger would refer to as Standing Reserve. People from all over the country once flooded into the site in order to exploit it's minerals and gain fortune. This inevitably lead to it's own sustainable demise, drying the deposits of their ore and eventually nearly leading to a ghost town. The only thing which saved the town was the profound natural beauty of the environment surrounding it.

In closing, gems, sustainability, and architecture are indissolubly linked into the unbreakable chain of culture, both historic and present. Revealing these connections is the endless task of the architect who unearths them. The thesis attempts to reconcile these relations into a sustainable architecture which is both technologically sufficient, and relevant to both modern and historical culture all the while delivering the thaumatic relationship to the body which the application of sustainable technology currently lacks.

Project Justification

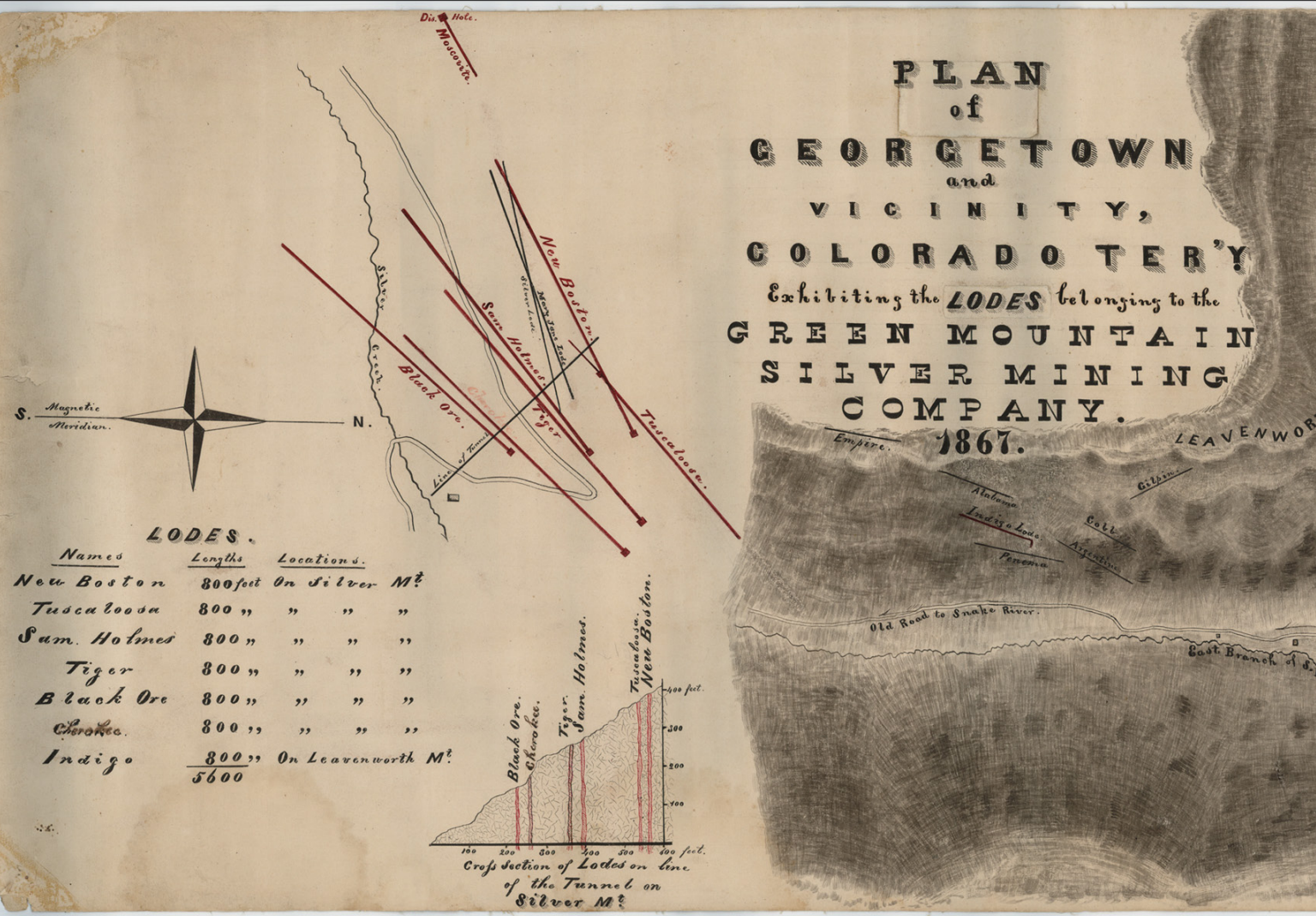
Sustainability has been a hot topic in architecture for many years, most prominently since the early 2000's. Most often sustainable practice is reduced to the scientific application of technology, as well as the use of objectively better materials. One could argue that there is nothing wrong with this objective application. Also, one could also argue that it could become subjectively and objectively better if it were instead integrated into the experience of the building rather than formulaically applied to something that is already designed as it so often is.

People truly are affected by the global, local, and intimate environments around them. Something as little as a gem can greatly influence the perception of a person in so far that it can nearly define their cultural status by its presence. I believe that sustainability can define architecture in a similar way. The problem is that is so often reduced to pure application of technology. Though the thesis uses this same technology, it is used in an experiential way rather than formulaic. Ritualistic rather than magic. Inter-subjectively rather than purely objective or subjectively. Through this use, as well as relationship to context and gems, I believe the architecture and sustainability can have a deeper relationship to the user's own personal context. When a person is experiencing the wonder of great architecture, I believe, they are at their most vulnerable point in realizing their own self-actualization; their own effect on the world surrounding.



Figure 21-11 Peter Zumthor's Bruder Klaus Chapel,
http://www.archite.ct/zumthor_capilla03.jpg

Historical, Social, and Cultural Context of Thesis



The Site

The building is nestled in the mountain valley of Georgetown, Colorado. Georgetown was founded in 1859 during the Pike's Peak Gold Rush. The notable silver mine of the town sustained it for over 80 years, until the early '30s when the silver veins were fully mined. Though its population is a bit over 1,000 people, the town was once the center of the mining industry in Colorado during the 19th century. Before the collapse of the silver boom, the town's population exceeded 10,000 and there were even thoughts of pronouncing Georgetown as the new capital of Colorado over Denver.



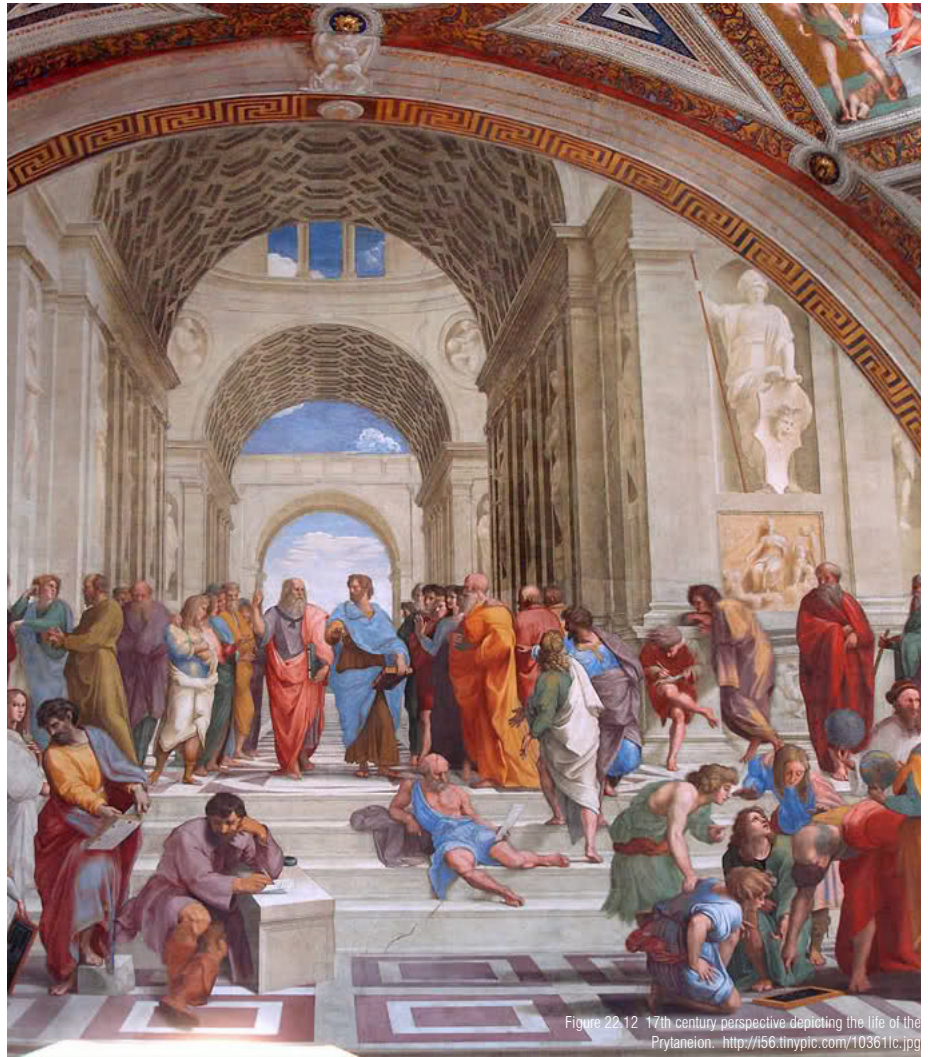
Figure 22-11 Georgetown map 1867. <http://www.raremaps.com/gallery/enlarge/20298>

Many of Georgetown's early historical documents were destroyed or lost in the disbanding of the town's people due to the mines running dry. This map is one of the few surviving documents showing the early city.

The idea of sustainability as stated earlier, is ever prominent surrounding the founding and practice in the Georgetown area. Through the unsustainable thinking of prospectors, the town never had a chance to truly flourish in the 20th and 21st century. There has, though, been a recent renaissance in the downtown area of the town which has converted the old 19th century buildings into renovated hobby, gift, and tourist shops. This and its great location for skiing seduces many people driving through the Colorado mountains to discover the town.

The Type

The museum has existed in many forms since the inception of artifact preservation. The preservation and display of artefact in the public realm was started in Greece through the existence of the Prytaneion and the definition of the mouseion (Seat of Muses) as a place of philosophical discussion and contemplation.^[1] The seat of Greek government was more than just a political place of discussion, but rather a place of contemplation not unlike the museum. Through the presentation and display of artifact in a set place, people were able to congregate and discuss deep cultural and philosophical ties through meaningful conversation. The artefacts were often valued for their craft or historical context relating to culture. Whether it be a relic of battles past, or a Daidalic artifact of the gods, culture was always about more than the banter which much of politics is reduced to today.



The word museum was relatively unused until the 15th century onward during the renaissance period where many well crafted relics and artefacts were made, or brought into the public realm out of private collections. The modern museum is a space of participation which is relatively unequaled in precedent by other building typologies. One could consider a theatre for performing arts the nearest equivalent as it is a presentation of a once performed artifact. Only a museum of gems, though, could speak to the rich mining history of Georgetown as well as the rich historical myths and lore of gems in ancient culture throughout history.

Metaphorical Relationship

Gems in culture have been coveted by all who hold them on a deep interpersonal level. Historically they have been valued not only by their craft, but often times by the magical qualities they were believed to possess. Today gems are deeply rooted into culture whether it be a symbol for personal affection and commitment for the Other, or self adornment and importance. They do not possess the myths that they once had, but still truly have the power to affect a space in a very experiential and spiritual manner. For example one could consider the presence of a ring at a wedding and how it changes the atmosphere. Or one could consider a woman adorned in a beautiful necklace and how the presence of a single piece of jewelry can truly change the definition of her own being.

Sustainability could metaphorically be considered the finely crafted and precisely honed jewelry of architecture. Through its presence one can start to define the quality and care taken into the design of the environment. As stated earlier it could be referred to being a refinement of culture as well, in that culture is ever reaching out to become more sustainable and pure; especially within the last 20 years of history. This is a very unique trait which sustainability holds solely over nearly every architectural article. It is not simply a trend reduced down to aesthetic to which architecture has historically answered the call. Rather it is a movement of both culture and practice which is likely to persist until the world can call itself energy independent of fossil fuels. This is why it is so important that it be integrated into the experience of the building, to allow for the experience of the gem, rather than reducing it to a sort of shiny jewel.



Figure 22.13 15th century artists depiction of Voluptus, Chastity, and Beauty adorned in rare stones: each a symbol of the three qualities required for pure attraction and seduction. <http://3hourspast.files.wordpress.com/2013/08/three-graces-clothes.jpg>

Architecture has always held the power of seduction through its form and order similarly to the power of the gem, as well as the seductive nature of the human experience. Buildings have the power to draw one into the experience of itself similarly to how gems have the power to draw the mind into the fire presented within.

Local Colorado Culture



Figure 22.14 - Denver Colorado skyline as seen today - <http://www.skyphoto.com/wp-content/uploads/2012/11/denver-city-park-aerial-s>

Colorado's people are very involved with art in local culture especially in the Denver area just East of the site. Since the dominant visitor's of the building will be from this area it is important to get a feel for the city. Experiencing the city from a first person perspective, one can notice how important the outdoors are to Coloradans. The major shopping center is a european-style outdoor mall with cafe's stretching into the streets. Many street artists are out and about creating their own impressions of what they believe to be important. The reason that many people will be passing through Georgetown on a weekly basis is to get to the mountains on the weekends to bike, hike, and in the winter ski and snowboard. This is how Georgetown draws many of it's visitors.

The culture is surrounded with the idea of the festival. On nearly a daily basis there is some sort of different music, art, or performance based festival somewhere in the city whether the weather cooperates or not. In Georgetown there are multiple music festivals a year celebrating local, and famous artists which also draw people to the city.



Figure 22.15 Georgetown Colorado Downtown. Photo credit Matt Qual.

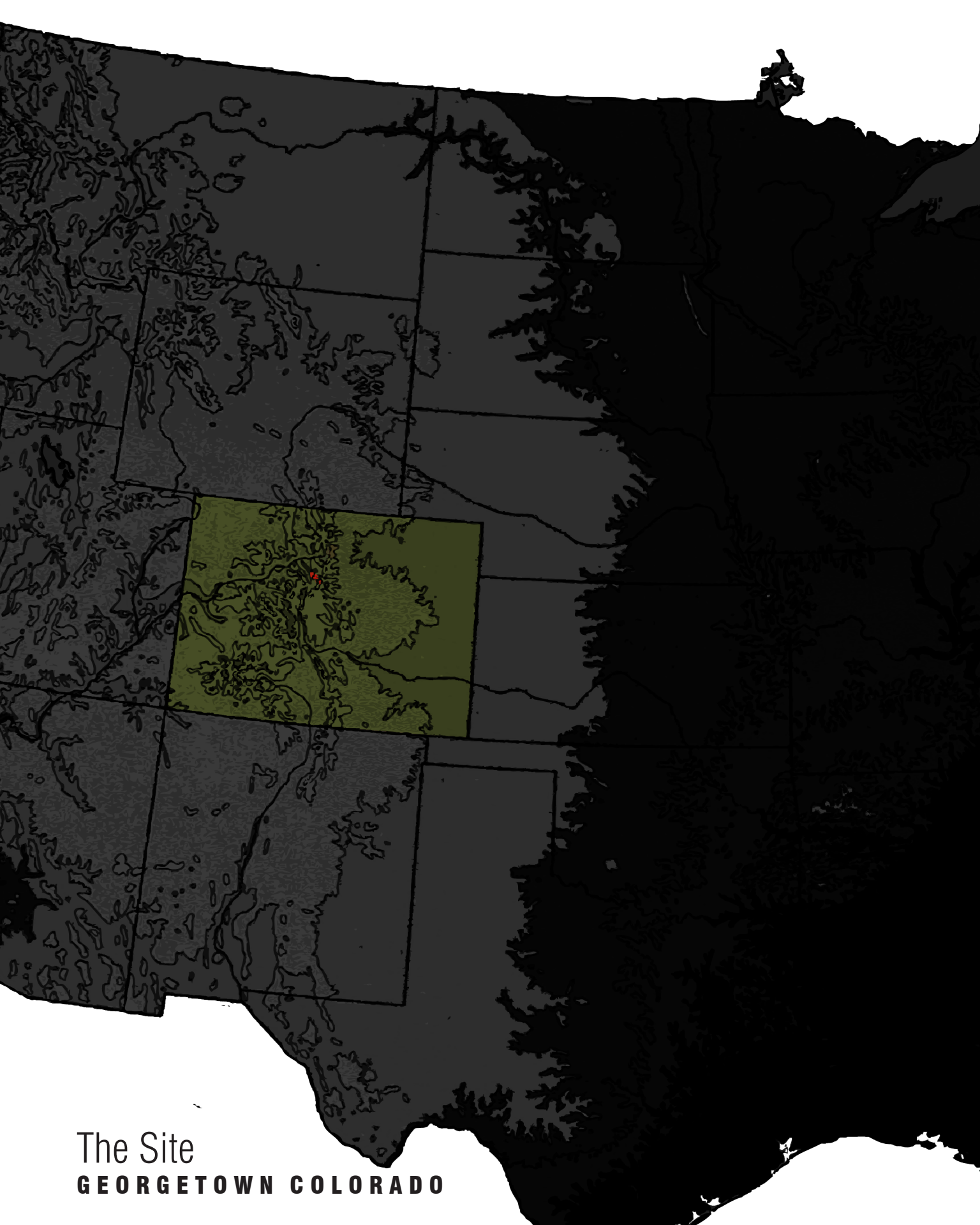
Georgetown's downtown is an interplay between the renovated 19th century historical mining buildings, and shops selling local art, crafted, and recreational items. The city is surprisingly bustling with tourists on summer days, with hundreds of new people stopping by in transit to other destinations, as well as some who made the town's historical context their destination. The Midwestern dwellers hold their quaint and friendly charm which is so often attributed to their culture.



Georgetown, Colorado is located on the fringe of the Continental Divide which separates the Western United States from the Great Plains to the East via the Rocky Mountains.

The Eisenhower Memorial Tunnel just miles West of the site is the major conduit which funnels tens of thousands of vehicles daily through the site.

Figure 23.11 United States of America Topographic Map Highlighting Georgetown, CO.



The Site
GEORGETOWN COLORADO

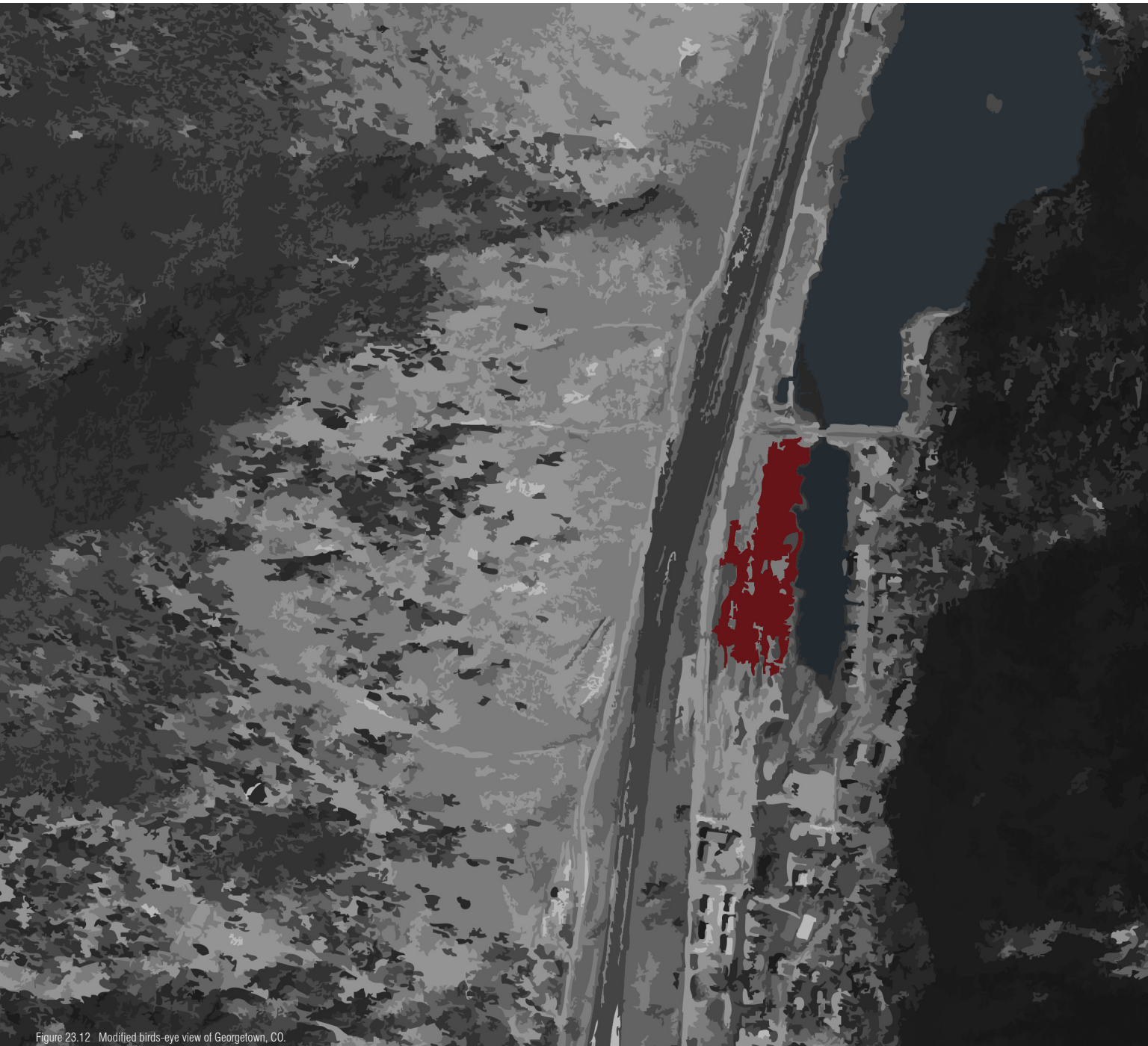


Figure 23.12 Modified birds-eye view of Georgetown, CO.

The Site

GEORGETOWN COLORADO



I-70 near Georgetown is a historically heavily traveled Interstate Highway. On average, the interstate serves 31,000 cars a day, but on winter weekends up to 100,000 take the highway daily. (<http://www.mesalek.com/colo/i70.html>) The town is nestled between Denver, CO and Frisco/Breckenridge, CO which is the weekend destination for tens of thousands of Denver dwellers. The users of the building are the passer byes, the otherwise situated onlookers. People who are in transit in the gridlock of the highway system, as well as the general public of the greater Denver area. The natural beauty of the site coaxes the busy city dwellers to take a moment to slow down.



LAKE



SITE



SILVER PLUME
MOUNTAIN



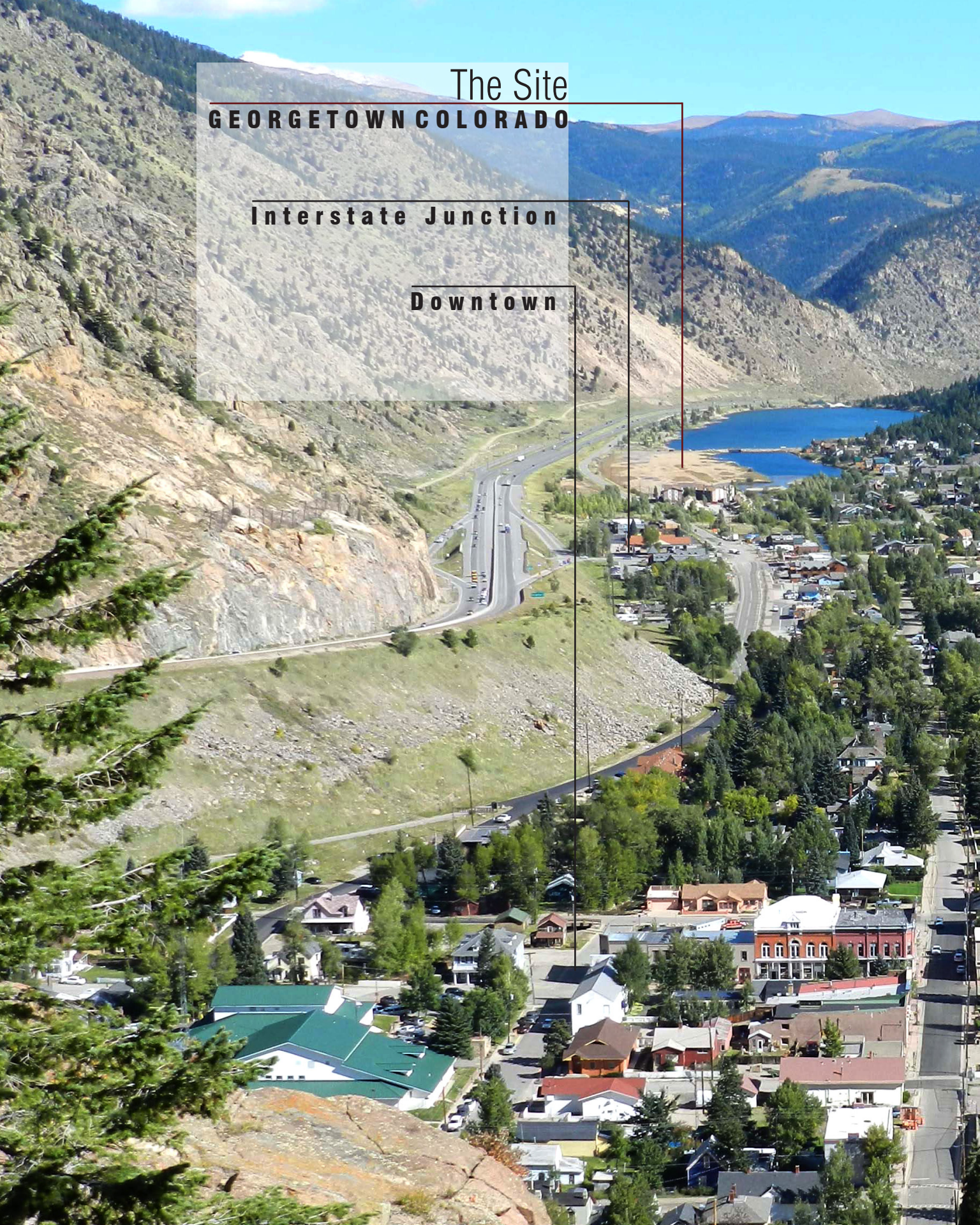
EAST MOUNTAIN SHADOWS
JUNE 21 2014
SUMMER SOLSTICE (10 AM)



INTERSTATE 70



GEORGETOWN



The Site

GEORGETOWN COLORADO

Interstate Junction

Downtown



Site Analysis

SILVER PLUME
MOUNTAIN

1 - 7 0

ALVARDO RD

← TO DOWNTOWN

WHITE RESERVOIR

SINGLE FAMILY
RESIDENTIAL

SAXON
MOUNTAIN

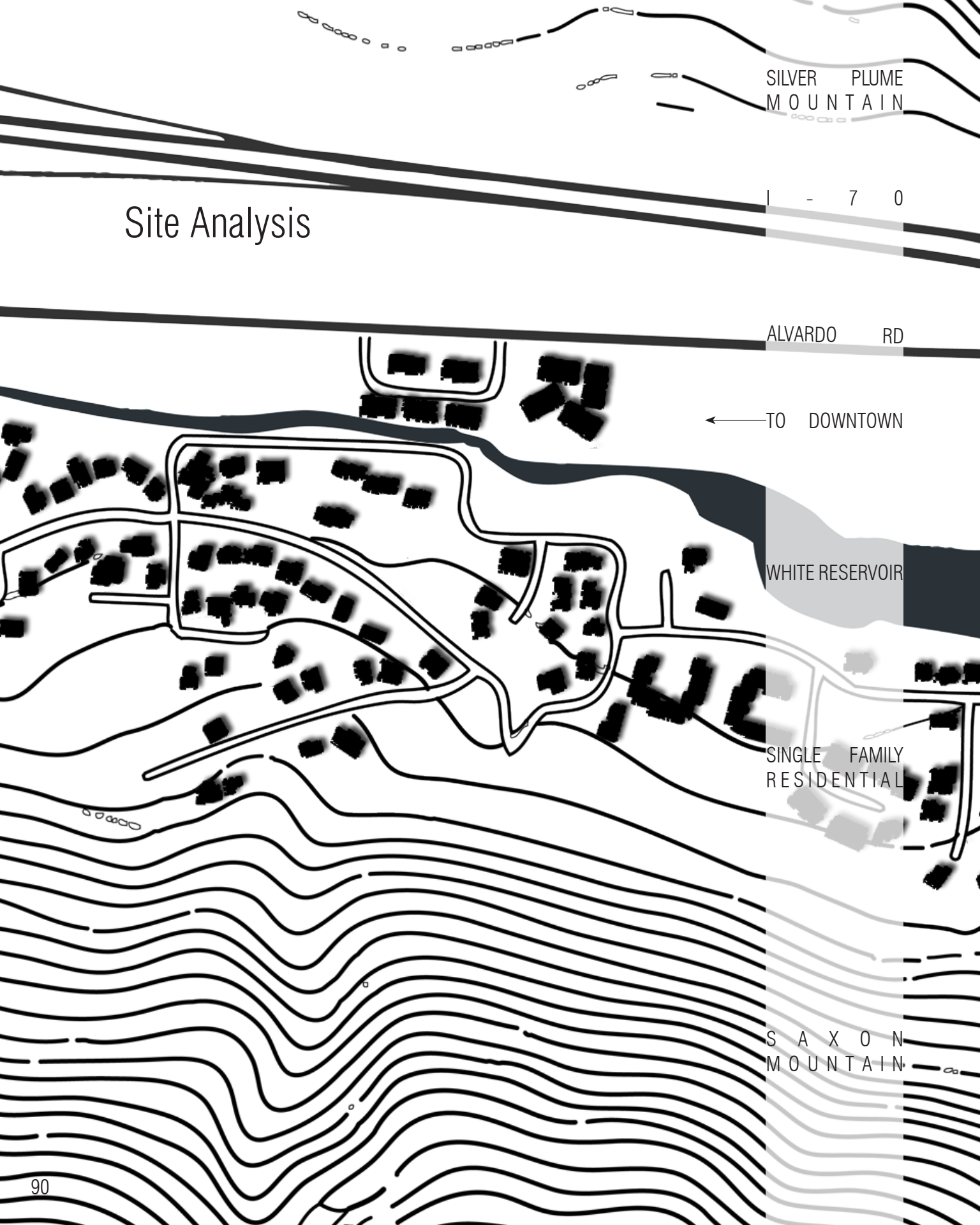




Figure 23.14 Overall Site Map

GEORGETOWN
L A K E



Site Section P 94

Views

Figure 23.15 Site View Map

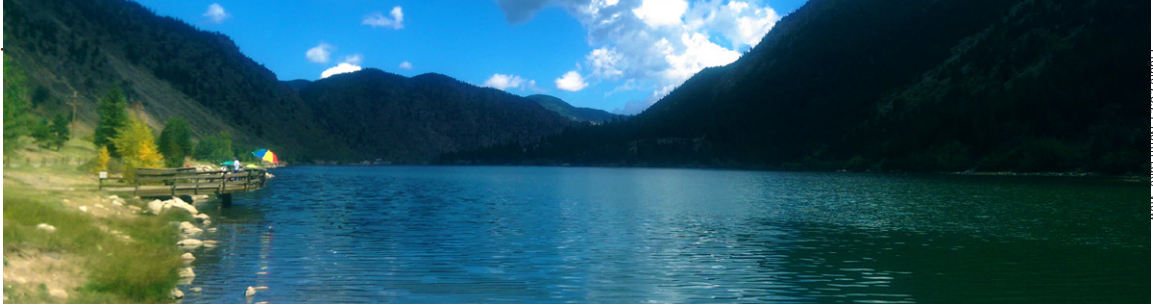


Figure 23.21 North Lake View



Figure 23.22 South Site Overlook



Figure 23.23 East of Site

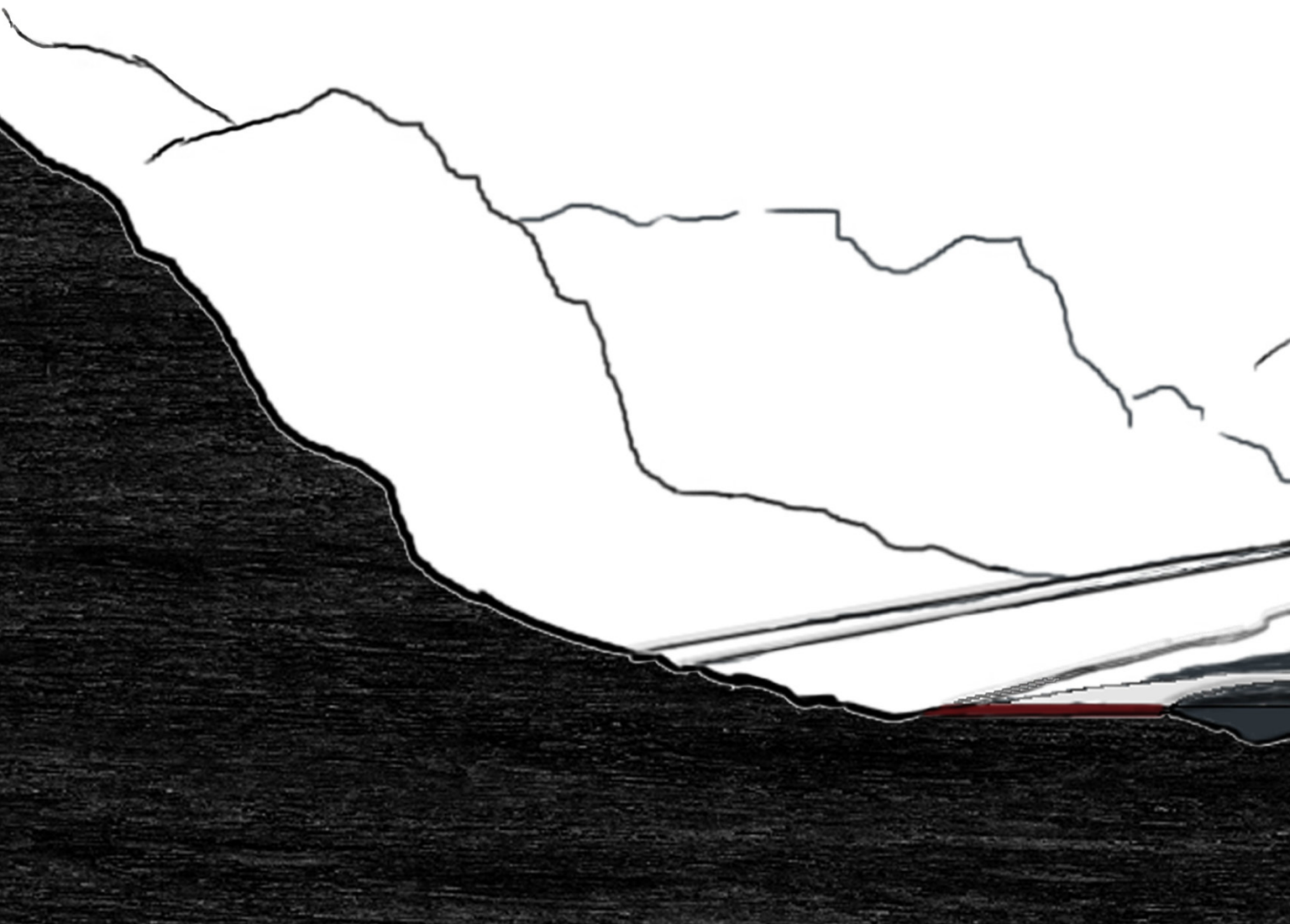


Figure 23.24 West of Site - Silver Plume Mountain



Figure 23.25 Looking Down

Site Section



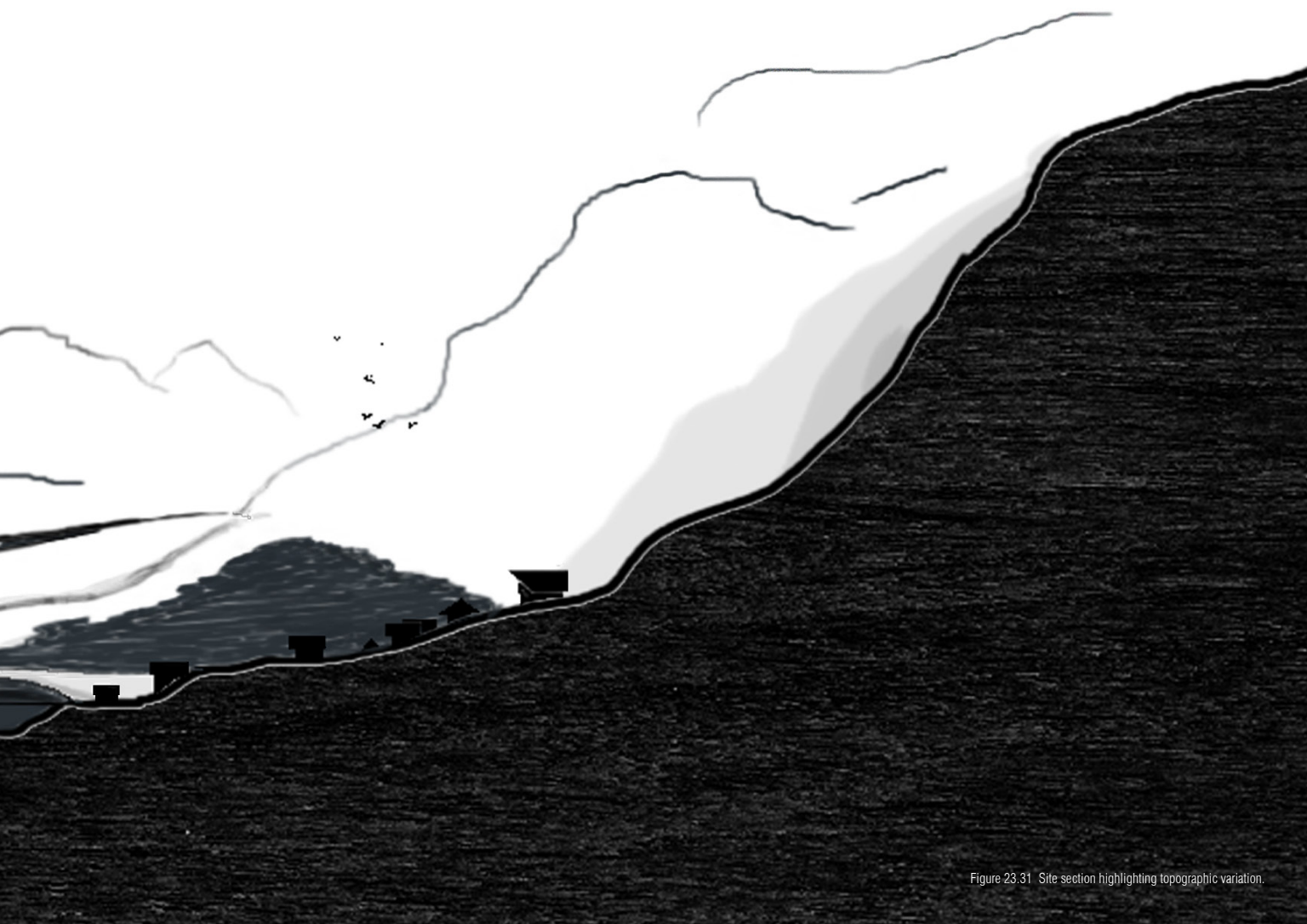
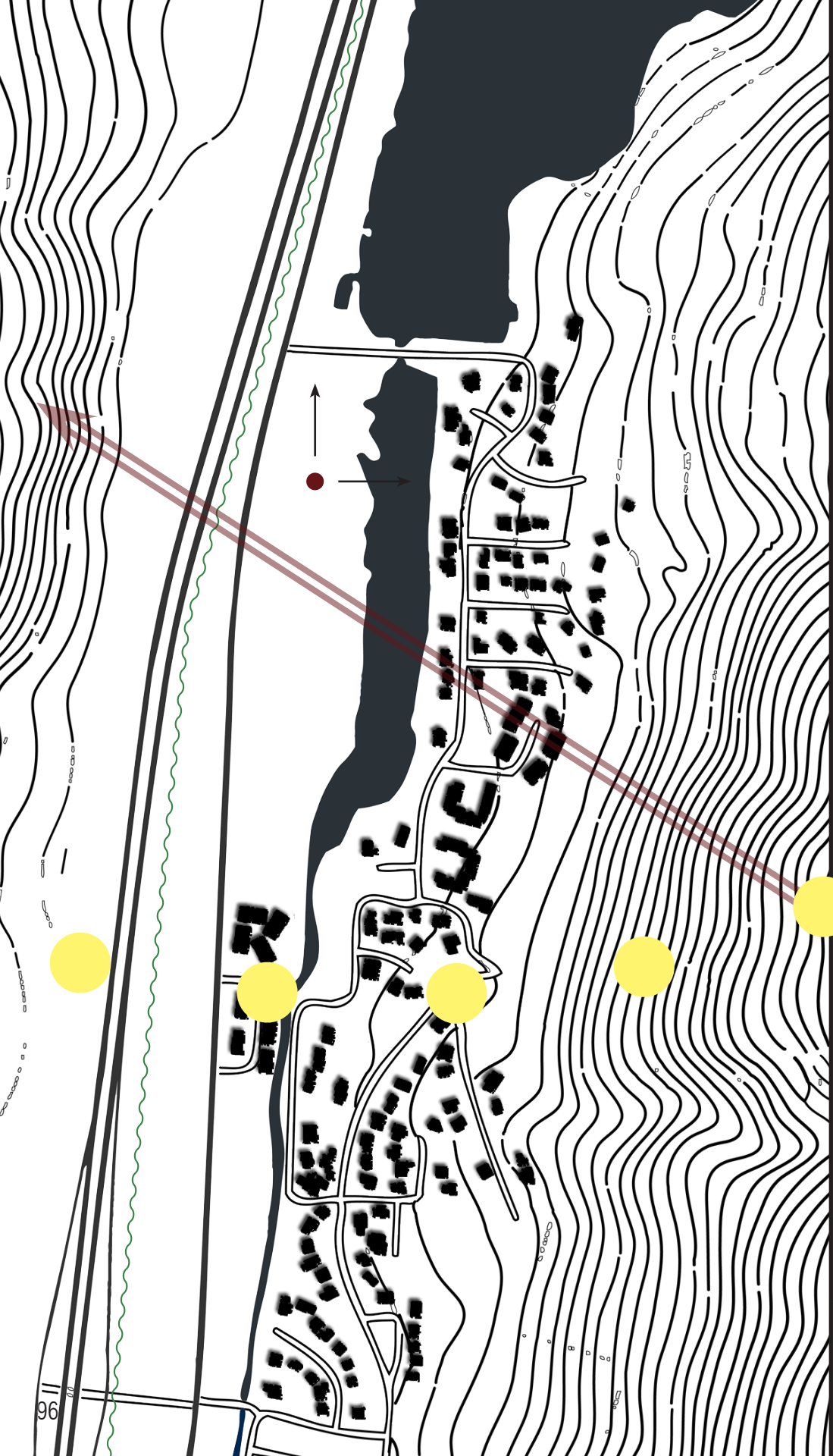


Figure 23.31 Site section highlighting topographic variation.



Dominant Wind



Views



Loud Traffic



Sun



Figure 23.32 Site map showing various features

Walking through the site during the summer months is a very comfortable experience. The large quantity of sunny days in Colorado brings warmth of light and touch. This contrasted with the cool crystal spring-fed lake brings many people to the site during the summer months. Many people go to the site to fish, relax, or float blissfully through the waters. Motor driven boats are not allowed on the lake, but canoes, and other paddle driven craft are allowed so long as things are kept peaceful.

The interstate highway beside the site is the major driving factor in luring people to the building. The thousands of cars driving adjacent to the site daily create a constant fluctuating hum of engines and tires on pavement. Trees and bushes could be used as a sound and visual barrier between the interstate and the site.

Major views are to North, East, and West, with the southern view currently being mostly crushed quartz and the town beyond. The most preferred views are the lake to the north North and mountain to the East. Since the site is mostly gravel it would be an opportunity to excavate the gravel surface, revealing the rich Millisil soils below.^[1]

As seen below, there are very few plants on site, The Eastern mountain is covered nearly fully with coniferous trees.

1. http://hydro_bm.esri.com/Soils/soilOrderMap2Beta.htm
Figure 23.33 Shadows and vegetation of the Eastern mountain. http://hydro_bm.esri.com/Soils/soilOrderMap2Beta.htm



The topography of the site is greatly varied. The surrounding mountains support much of the local economy through winter sports and summer hiking, while the valley supports lake side lounging and fishing. Erosion is a major problem along the mountain cliffs concerning safety on the highway and outer townscape. The site, though, is mostly flat and safe in the valley between the peaks. The site lies on a 2% grade sloping into the lake. The sandy rocky surface soils of eroded mountain runoff mask the rich farmland soil underneath. Stripping away the surface soil opens a great opportunity for an exterior park .

Lake Georgetown was formed as a power source for the city. Since the city was at one time very remote, Hydroelectric power was taken advantage of by damming the once stream as seen on the upper topographic photograph.

Figure 23.34 Georgetown Fly-through overlook. Image via Google Earth.



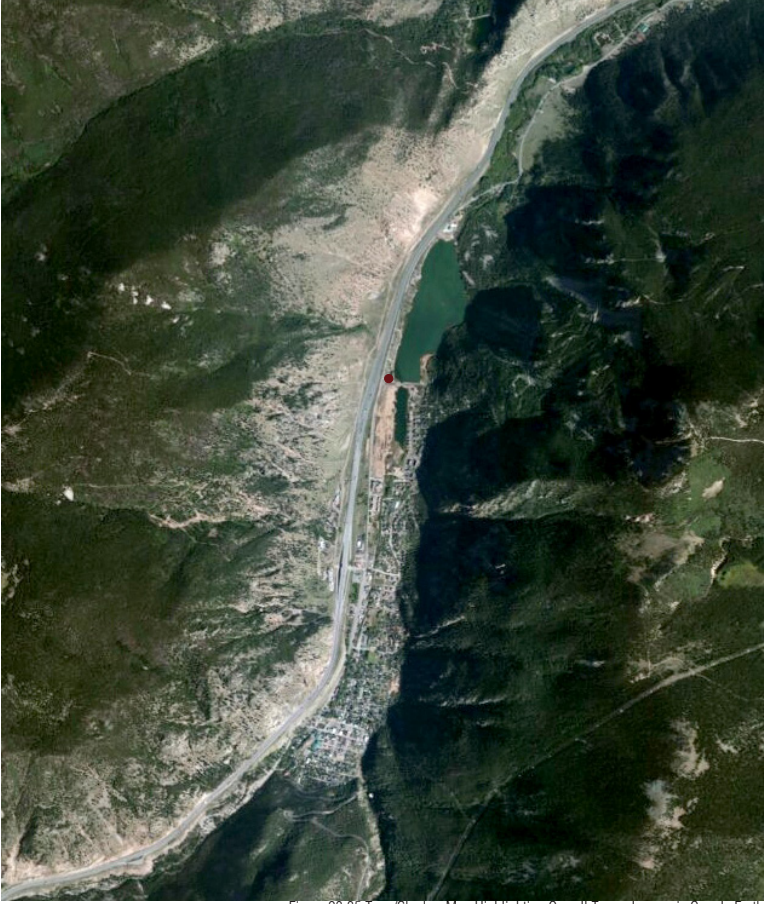


Figure 23.35 Topo/Shadow Map Highlighting Overall Town. Image via Google Earth.

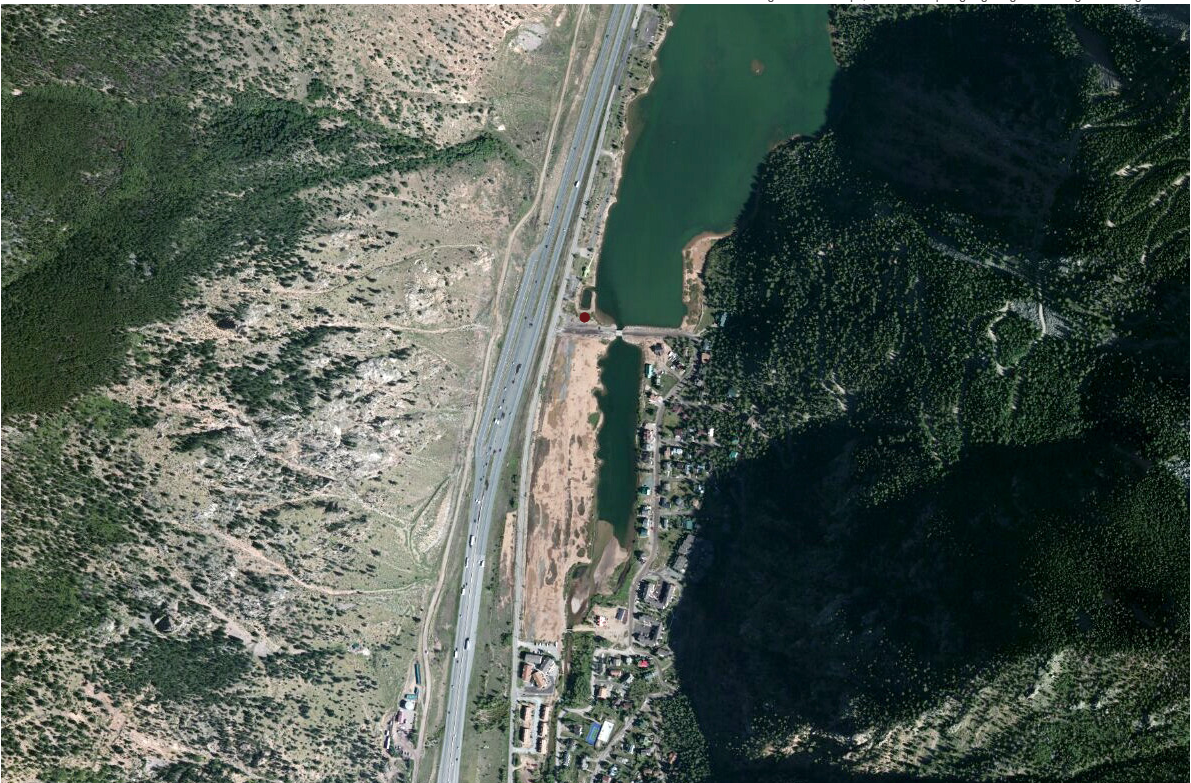


Figure 23.41 Topo/Shadow Map Highlighting Site. Image via Google Earth.



Pickup truck for scale.



Figure 23.42 Site Vegetation and Lighting. Photo Matt Qual

During the day, the site is flooded with Colorado's warm natural sunlight. With an average of 245^[1] days a year being sunny, thermal gain and solar power are common sustainable technologies taken advantage of.

The site's major vegetation consists of Douglas-fir, Blue Spruce, and patchy prairie grass. Along the banks of the lake the grass is lush and thick, soon thereafter dissipating into the infertile crushed quartz gravel. Wild brush grows sparsely along the banks of the water, as well as along the interstate highway.

The valley's soil type is Mollisol- indicating that under the sandy surface lies soil abundant in rich nutrients.



Figure 23.43 Reference Map.

1. <http://www.currentresults.com/Weather/Colorado/annual-days-of-sunshine.php>

LOOKING NORTH





Figure 23.44 Georgetown Lake. Photo credit Matt Quai

Georgetown Lake is a crystal clear spring fed reservoir which stretches far North of the site. The still shimmering of the lake was a major inspirational factor when determining the building typology. The water in the White Reservoir East of the site intermittently overflows onto the site every spring as the mountain snow melts away.

Humans use the lake largely for fishing, swimming, and relaxation during the summer months. The lake is the major reason Georgetown still exists today since over 30% of the population relies on entertainment and recreation as their major source of income as provided by the lake's existence.

Many people stop by the town drawn solely by the natural beauty of the shimmering waters.



Figure 23.45 Reference map.

LOOKING SOUTH





Figure 23.51 Southern townscape. Photo credit Matt Quai

South of the site White Reservoir carries onward toward downtown. The downtown is characterized by many 19th century mining buildings which have been refurbished as craft, art, and mercantile stores selling custom paintings, antiques, hobby items, stones, and other collectibles. Much of the town's culture is driven by the economics of the entrepreneurs living there.



Figure 23.52 Reference map.

LOOKING EAST





Figure 23.53 East reservoir and mountain.

Looking East one can truly gain a sense of the vegetation and character of the site. Across the pond are single family residential dwelling units dwarfed by the massive mountain beyond.

Since the site is surrounded by mountains on both the East and West, early morning and late evening direct sunlight will be out of the question. Therefore, many opportunities for sustainable practices will be limited to the short mid-day window.

The clearness of the pond could be somehow harnessed by the architecture. Perhaps if delving underground takes place, one could filter light through the clear waters.



Figure 23.54 Reference map.

LOOKING WEST





Figure 23.55 Silver plume mountain. Photo credit Matt Qual

Georgetown was founded during the Pike's Peak Gold Rush in 1858. While gold was the main drive for the initial rush, silver was later found to be nearly as valuable. The Georgetown silver mine is one of the town's current main public attractions which allows for the town to be a major tourist attraction.

The mountain of metamorphic rock to the west of the site is one of the driving typological generators for the thesis. The cracking and breaking of the layers can be related to one of the core ideas, being a natural process of experiencing something in a new way.



Figure 23.61 Reference map.

Sun

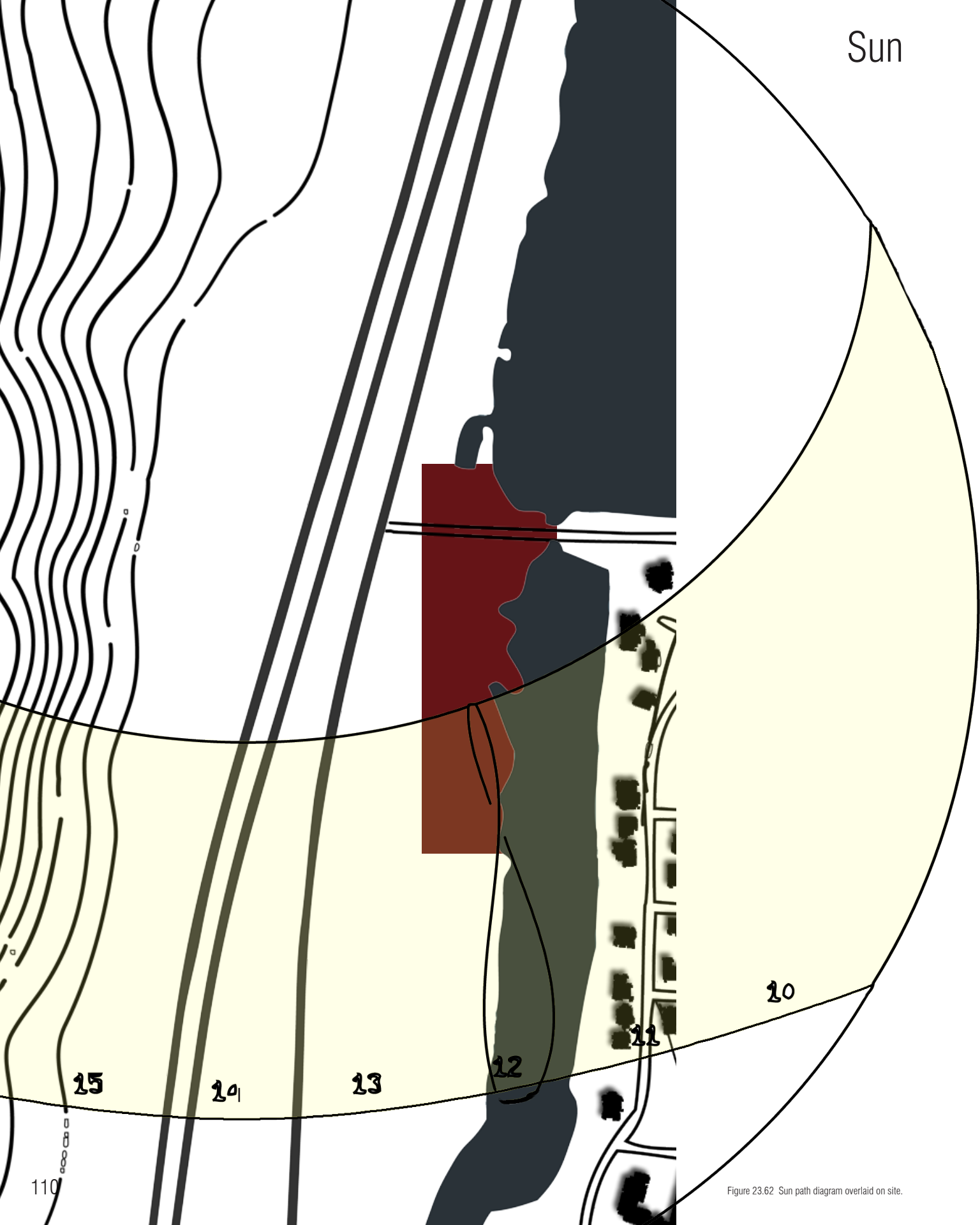
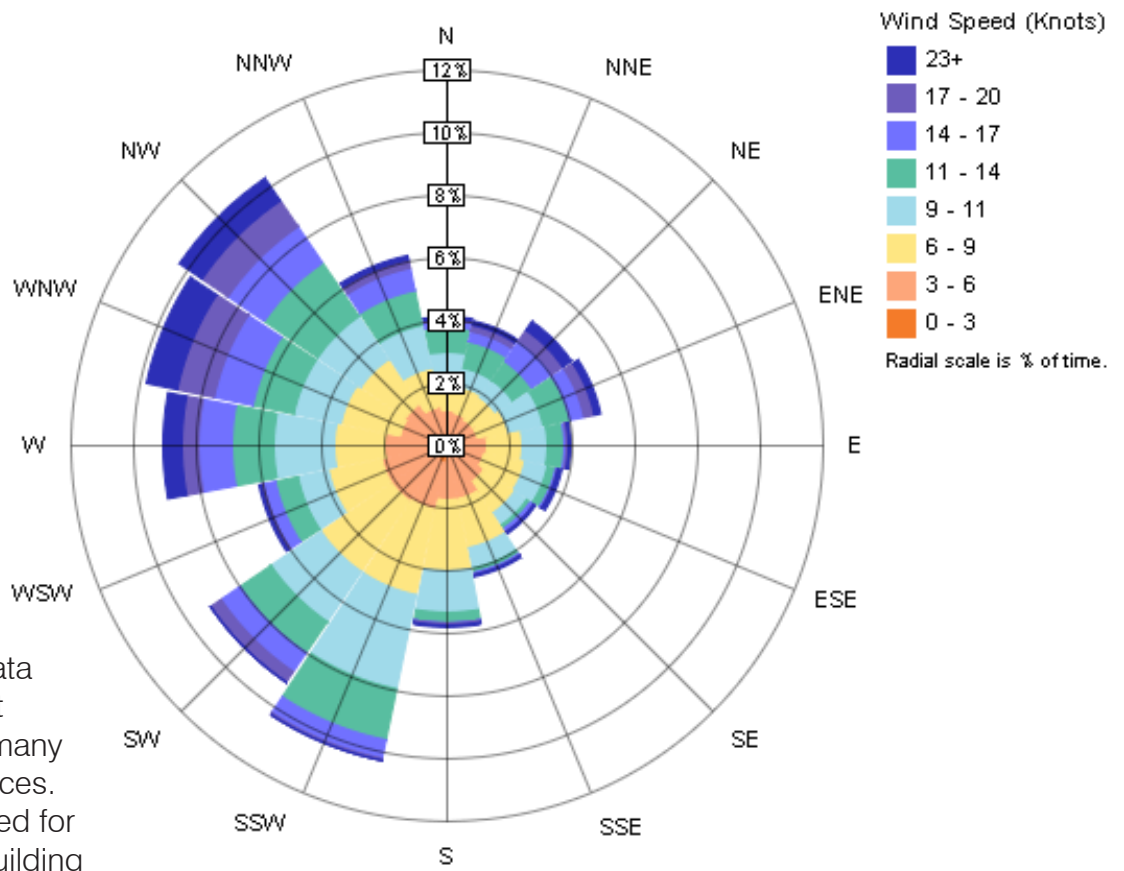


Figure 23.62 Sun path diagram overlaid on site.

Wind



Wind and solar data are very important when evaluating many sustainable practices. This was accounted for when choosing building orientation, solar gain, solar power, and wind generation techniques as well as sheltering and shading different areas of the building.

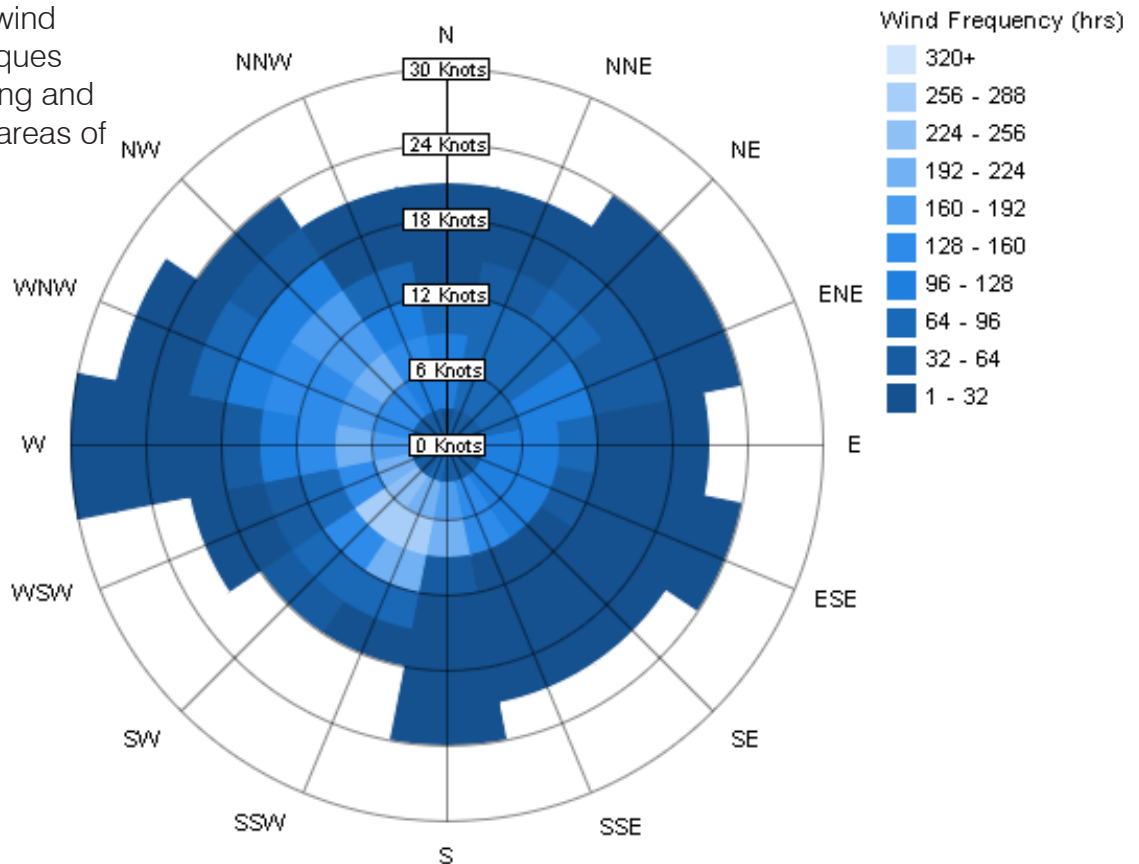


Figure 23.63 Wind rose diagrams. Graphic data retrieved via Autodesk Revit software.

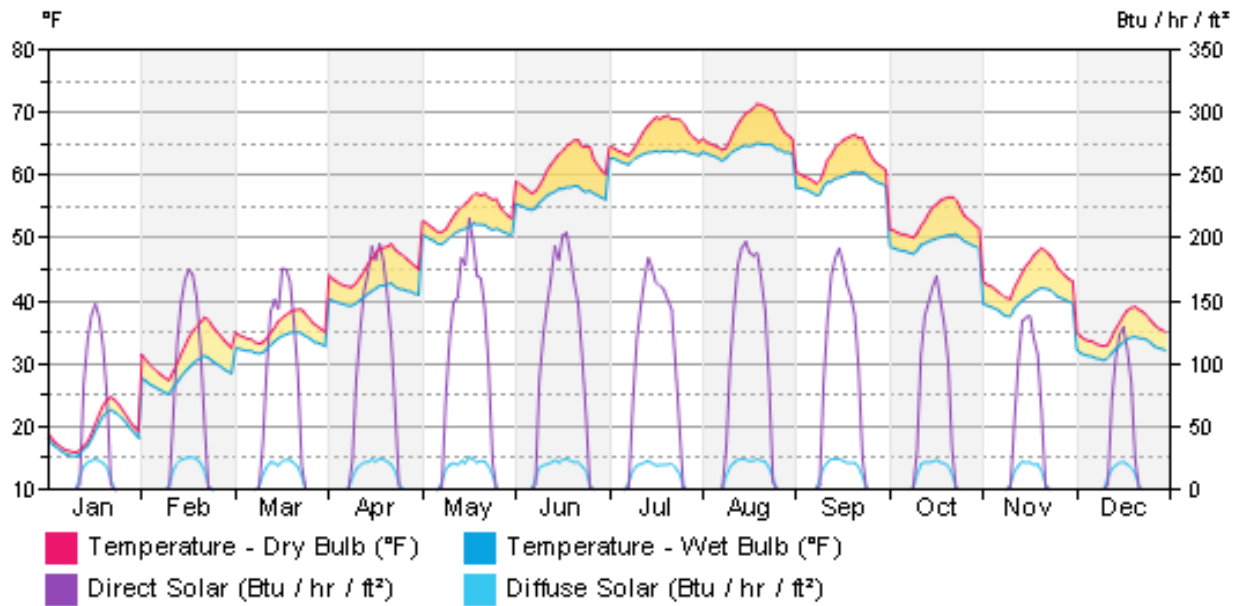


Figure 23.64 Solar gain. Graphic data retrieved via Autodesk Revit software.

Solar Gain

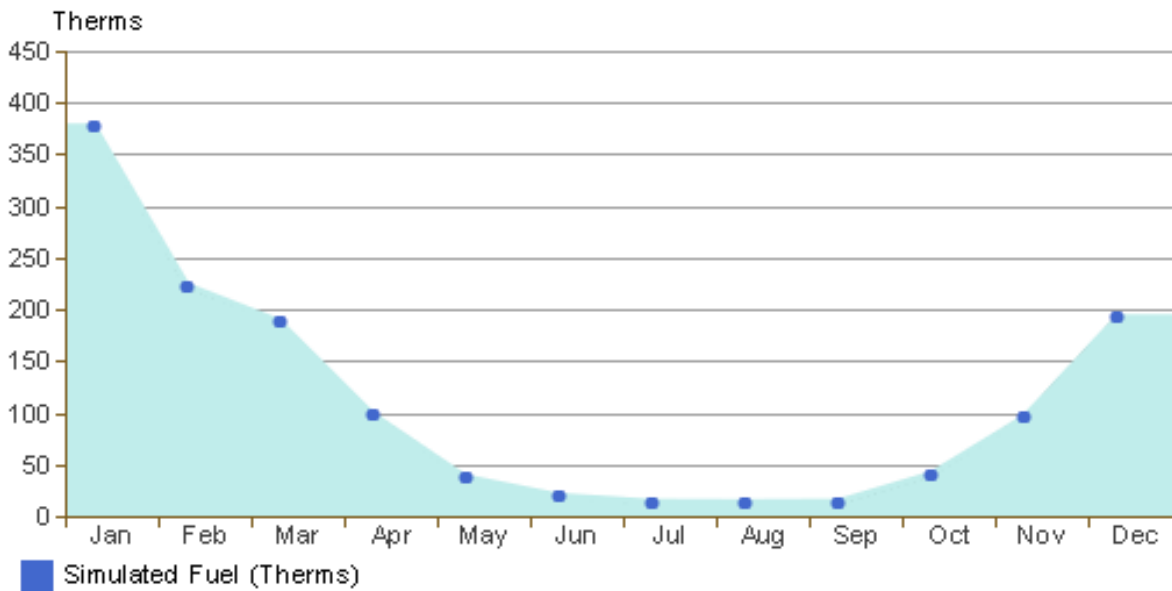


Figure 23.65 Estimated Fuel Proportions. Graphic data retrieved via Autodesk Revit software.

Estimated Fuel Proportions

Reviewing the climate data reveals that much of the thermal loads required will be for heating. Therefore sustainable systems such as thermal mass, trombe walls, and natural convection circulation should be taken advantage of. Since the majority of the days in the area are sunny, it is also logical to use a lot of natural lighting, as well as solar energy producing systems.

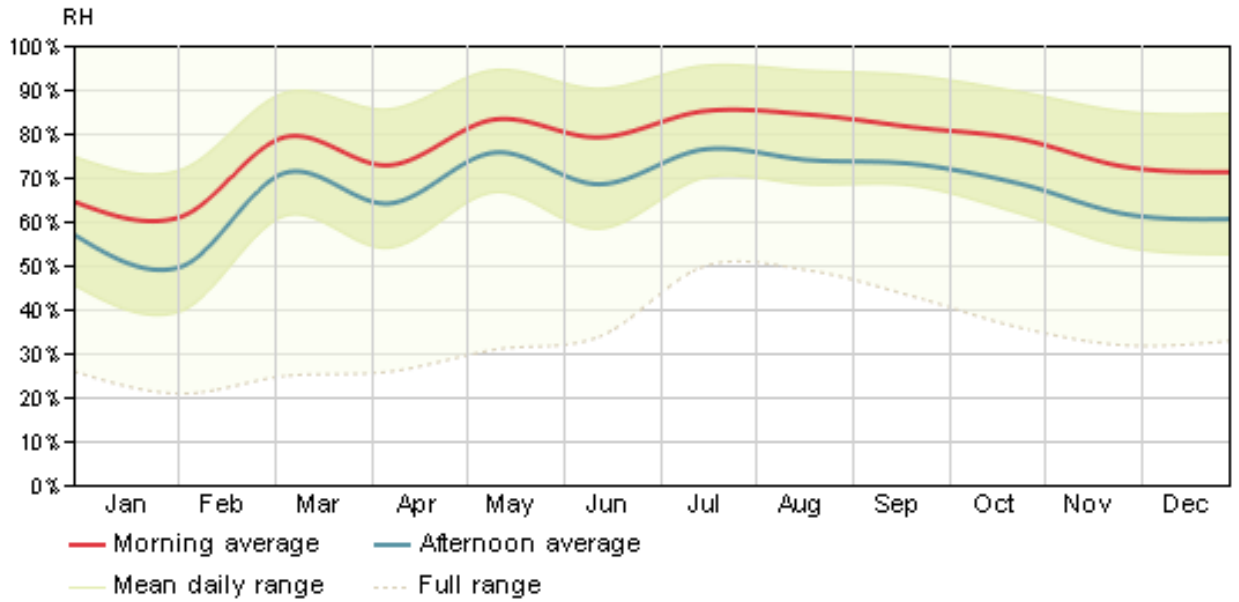


Figure 23.71 Relative humidity. Graphic data retrieved via Autodesk Revit software.

Relative Humidity

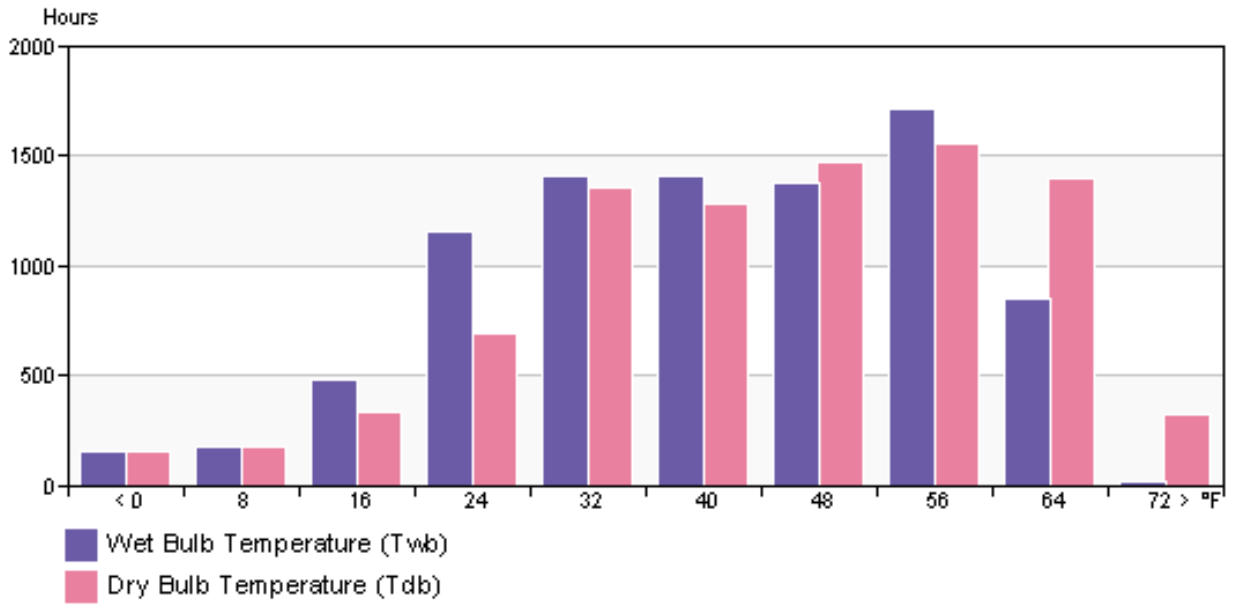


Figure 23.72 Bulb related temperatures. Graphic data retrieved via Autodesk Revit software.

Bulb Temperatures

Rain and Snow

	Jan	Feb	Mar	Apr	May	Jun
Average high in °F:	35	37	42	48	58	69
Average low in °F:	13	13	19	25	34	41
Av. Precipitation in inch:	0.71	0.87	1.65	2.09	2.05	1.73
Days with precipitation:	-	-	-	-	-	-
Hours of sunshine:	-	-	-	-	-	-
Average snowfall in inch:	13	11	21	22	6	0

	Jul	Aug	Sep	Oct	Nov	Dec
Average high in °F:	76	73	67	56	42	34
Average low in °F:	48	46	38	29	20	14
Av. Precipitation in inch:	2.2	2.28	1.54	1.34	0.98	0.91
Days with precipitation:	-	-	-	-	-	-
Hours of sunshine:	-	-	-	-	-	-
Average snowfall in inch:	0	0	2	7	12	14

Georgetown weather averages

Annual high temperature:	53.1°F
Annual low temperature:	28.3°F
Average temperature:	40.7°F
Average annual precipitation - rainfall:	18.35 inch
Av. annual snowfall:	108 inch

Figure 23.73 Average rain and snowfall statistics. <http://www.usclimatedata.com/climate/georgetown/colorado/united-states/usco0548>

Annual averages of rain and snow indicate that the town gets an average of 9 feet of snow on an annual basis. Designing for large snow loads, as well as creatively taking advantage of the snowfall should be considered.

The mean annual temperature being 40 Degrees Fahrenheit indicates an opportunity for outdoor plazas and seating. Once again, keeping in mind the annual snowfall.

The site lies in the Highland climate region. The Highland climate region's sustainable practices vary greatly due to different mountain conditions affecting specific sites. Prospect-able strategies include but are not limited to: Solar Gain, Solar Power, Trombe Walls, Passive Convection Air Circulation, Thermal Mass, Aquatic Thermal Mass, Night Flush Cooling, and Solar Chimneys.

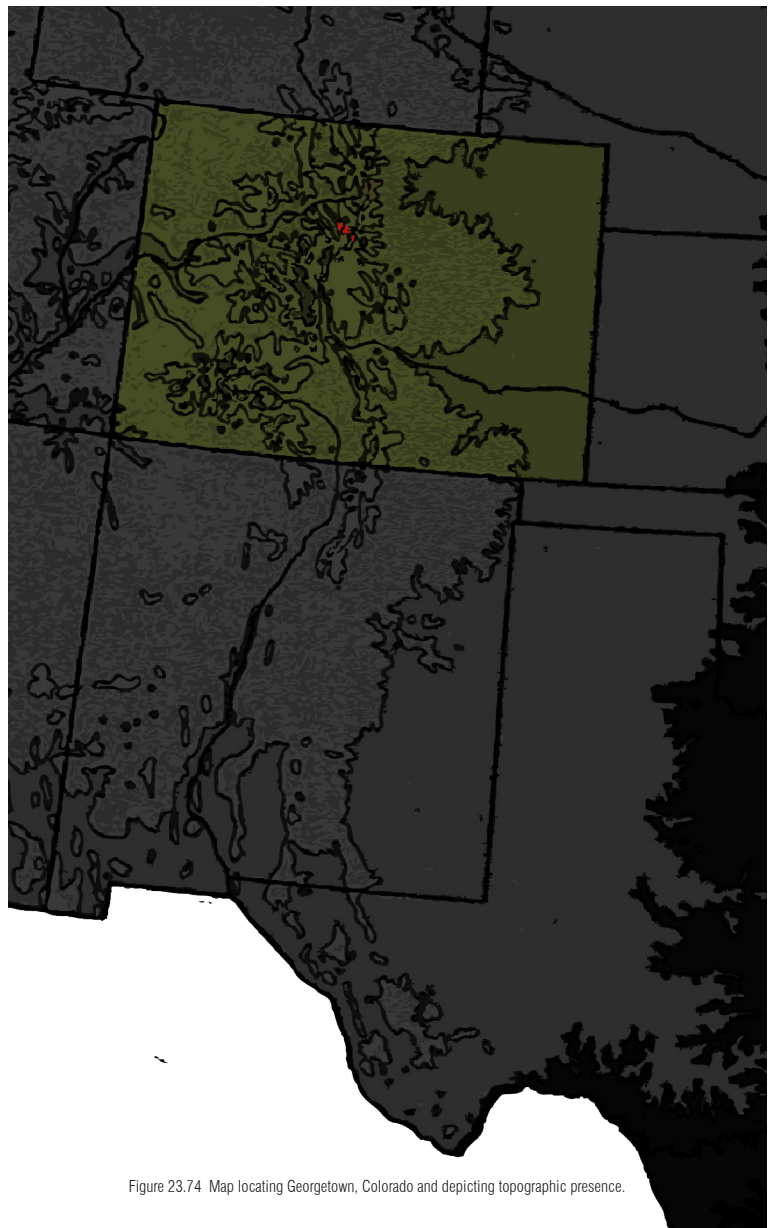


Figure 23.74 Map locating Georgetown, Colorado and depicting topographic presence.

Demographics

Race	Georgetown	Colorado	National
Caucasian	90.01%	84.15%	74.17%
African American	1.17%	3.99%	12.56%
Asian	0.17%	2.71%	4.81%
American Indian	3.75%	0.97%	0.82%
Native Hawaiian	0.00%	0.12%	0.17%
Mixed race	0.33%	3.31%	2.68%
Other race	4.58%	4.74%	4.79%

Figure 23.75 <http://www.city-data.com/city/Georgetown-Colorado.html#ixzz3Lwi88jje>

Population

Date	Number	Percentage Change
1880	3,294	100%
1890	1,927	-41.5%
1900	1,418	-26.4%
1910	950	-33.0%
1920	703	-26.0%
1930	145	13.3%
1950	329	126.9%
1960	307	-6.7%
1970	542	76.5%
1980	830	53.1%
1990	891	7.3%
2000	1,088	22.1%
2010	1,034	-5.0%

Figure 23.81 <http://www.city-data.com/city/Georgetown-Colorado.html#ixzz3Lwi88jje>

Crime rates in Georgetown by Year

Type	2004	2005	2012
Murders	0	0	0
per 100,000	0	0	0
Rapes	0	0	
per 100,000	0	0	0
Robberies	0	0	0
per 100,000	0	0	0
Assaults	2	1	4
per 100,000	179	91	385
Burglaries	5	6	3
per 100,000	448	551	288
Thefts	18	1	
per 100,000	1615	1377	96
Auto thefts	0	0	0
per 100,000	0	0	0
Arson	0	0	
per 100,000	0	0	0

Figure 23.82 <http://www.city-data.com/city/Georgetown-Colorado.html#ixzz3Lwi88jje>

Jobs

2012 Share of Jobs by Industry

Sector Name	Clear Creek	Georgetown
Agriculture	0.0%	0.0%
Mining	22.6%	0.0%
Utilities	0.8%	2.1%
Construction	2.6%	0.8%
Manufacturing	0.7%	0.0%
Wholesale Trade	1.2%	0.7%
Retail Trade	6.4%	6.9%
Transportation & Warehousing	1.6%	6.0%
Information	0.9%	0.0%
Finance and Insurance	0.6%	0.8%
Real Estate and Rental and Leasing	0.9%	0.1%
Professional and Technical Services	3.3%	1.3%
Management of Companies	0.1%	0.2%
Administrative and Waste Services	1.3%	0.8%
Educational Services	22.6%	0.0%
Health Care and Social Assistance	1.7%	0.4%
Arts, Entertainment, and Recreation	10.3%	33.4%
Accommodation and Food Services	20.3%	9.4%
Other Services	2.8%	0.0%
Government	21.8%	37.1%

Figure 23.83 <http://www.town.georgetown.co.us/Town%20News/Georgetown%20Overview.pdf>

Final Building Program 66,200 S.F.

Figure 24.11 Approximate Numbers via <https://www.wbdg.org>

Space	Square Footage	Use	Depth
Exterior Park	20,000 S.F.	Public	Varies
Lobby	700 S.F.	Public	Surface
Cafe	1000 S.F.	Public	Surface
Retail	500 S.F.	Public	Surface
Lounge	500 S.F.	Guests	Surface
Entry Exhibition	5,000 S.F.	Guests	Subsurface
Temporary Exhibition	5,000 S.F.	Guests	Underground
Perminant Exhibition	5,000 S.F.	Guests	Underground
Conference	800 S.F.	Guests	Underground
Cleansing	800 S.F.	Rentable	Varies
Auditorium	4,800 S.F.	Rentable	Underground
Workshop	1,500 S.F.	Rentable	Underground
Gemsmith	500 S.F.	Guests	Varies
Metalsmith	1,000 S.F.	Guests	Varies
Parking	10,000 S.F.	Guests	Underground
Loading Dock	500 S.F.	Private	Underground
Art Storage	2,000 S.F.	Private	Underground
Admistration	2,500 S.F.	Private	Underground
Securty	800 S.F.	Private	Underground
Custodial	800 S.F.	Private	Underground
Mechanical	2,500 S.F.	Private	Underground

The museum's hours of operation are from 9-5 weekdays, 9-9 weekends.

Since light control variation is important to gems, much of the light for the galleries is brought underground from the surface. Any painted object is either white or black as to not distract from the brilliance of the artefacts. Most materials of the place are left rough, as excavated from the earth. Contrarily, any material which can be purified, polished, or precicely crafted to exemplify it's natural beauty is crafted as such.

Left: Preliminary square footages.

Below: Preliminary space allocation matrix

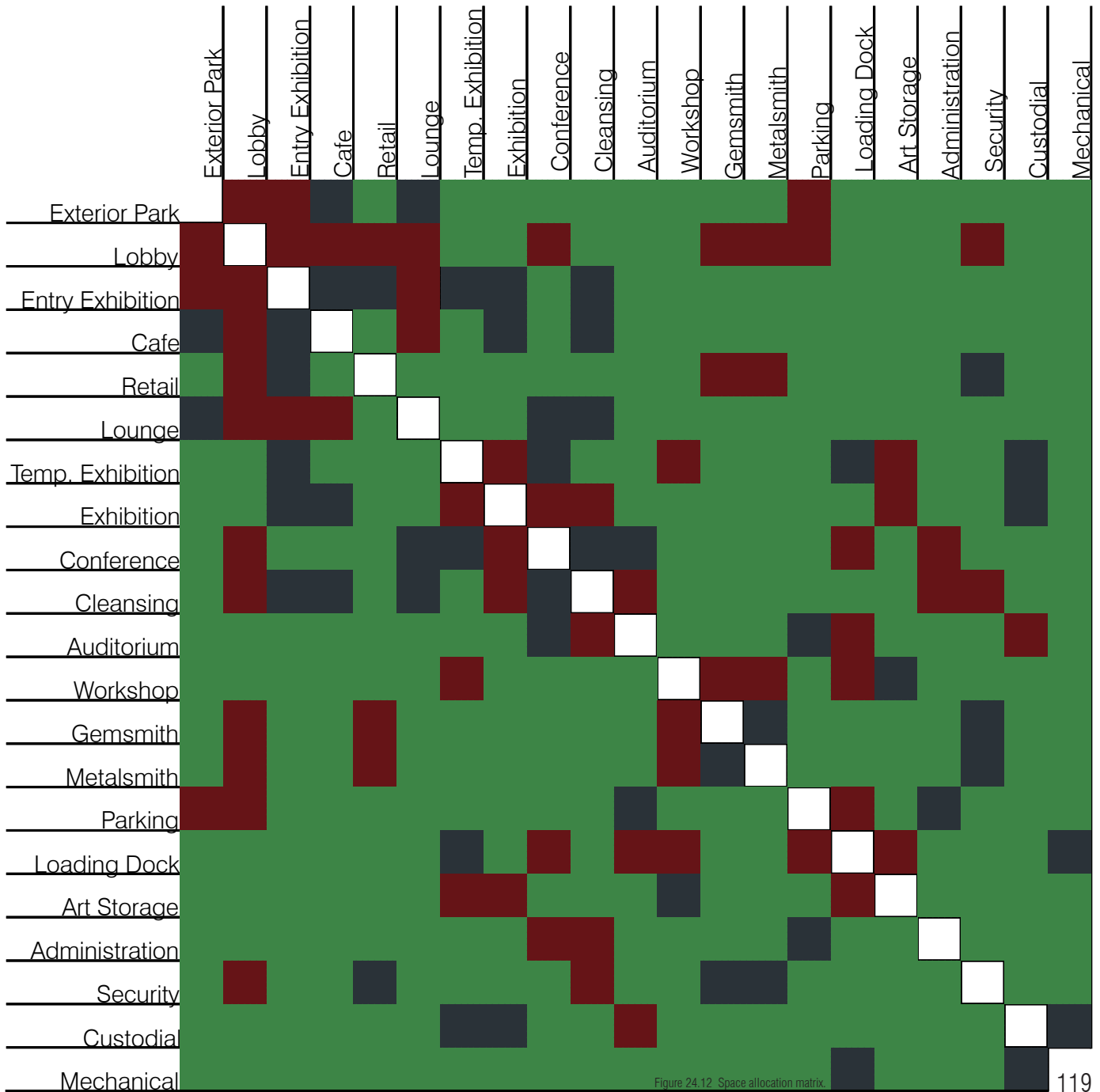
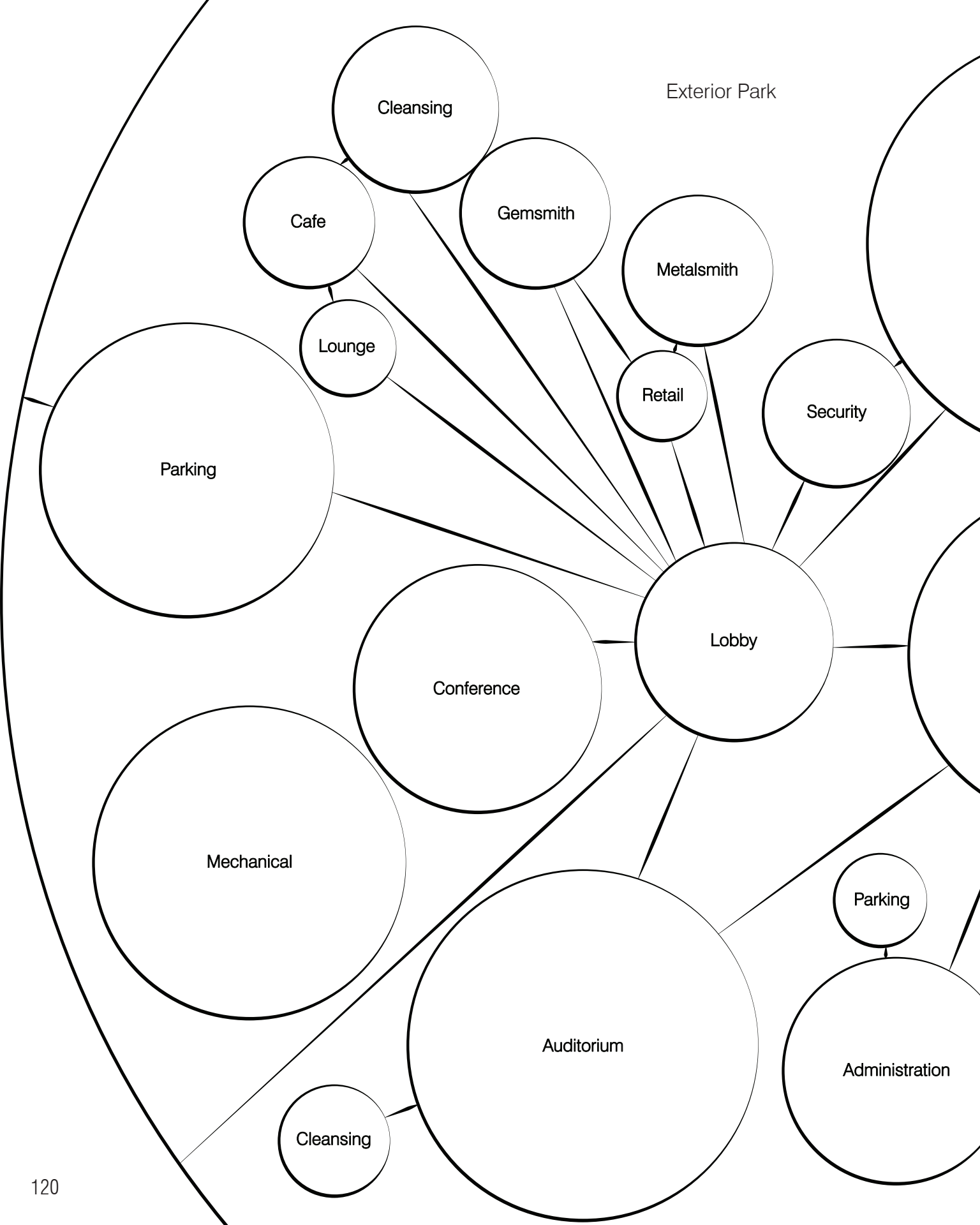


Figure 24.12 Space allocation matrix.



Exterior Park

Cleansing

Cafe

Gemsmith

Metalsmith

Lounge

Retail

Security

Parking

Lobby

Conference

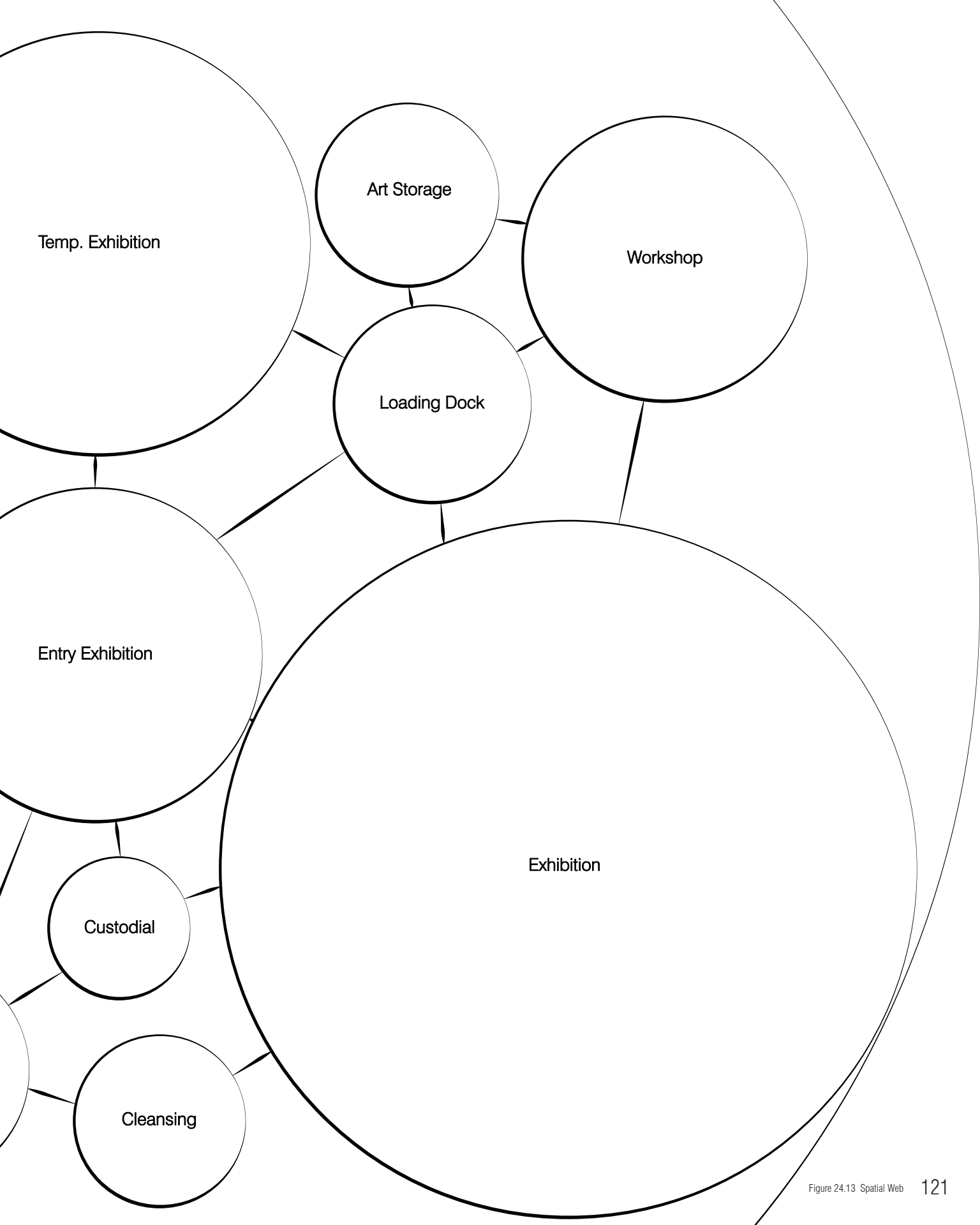
Mechanical

Auditorium

Parking

Administration

Cleansing



30.0

THE

NATIONAL

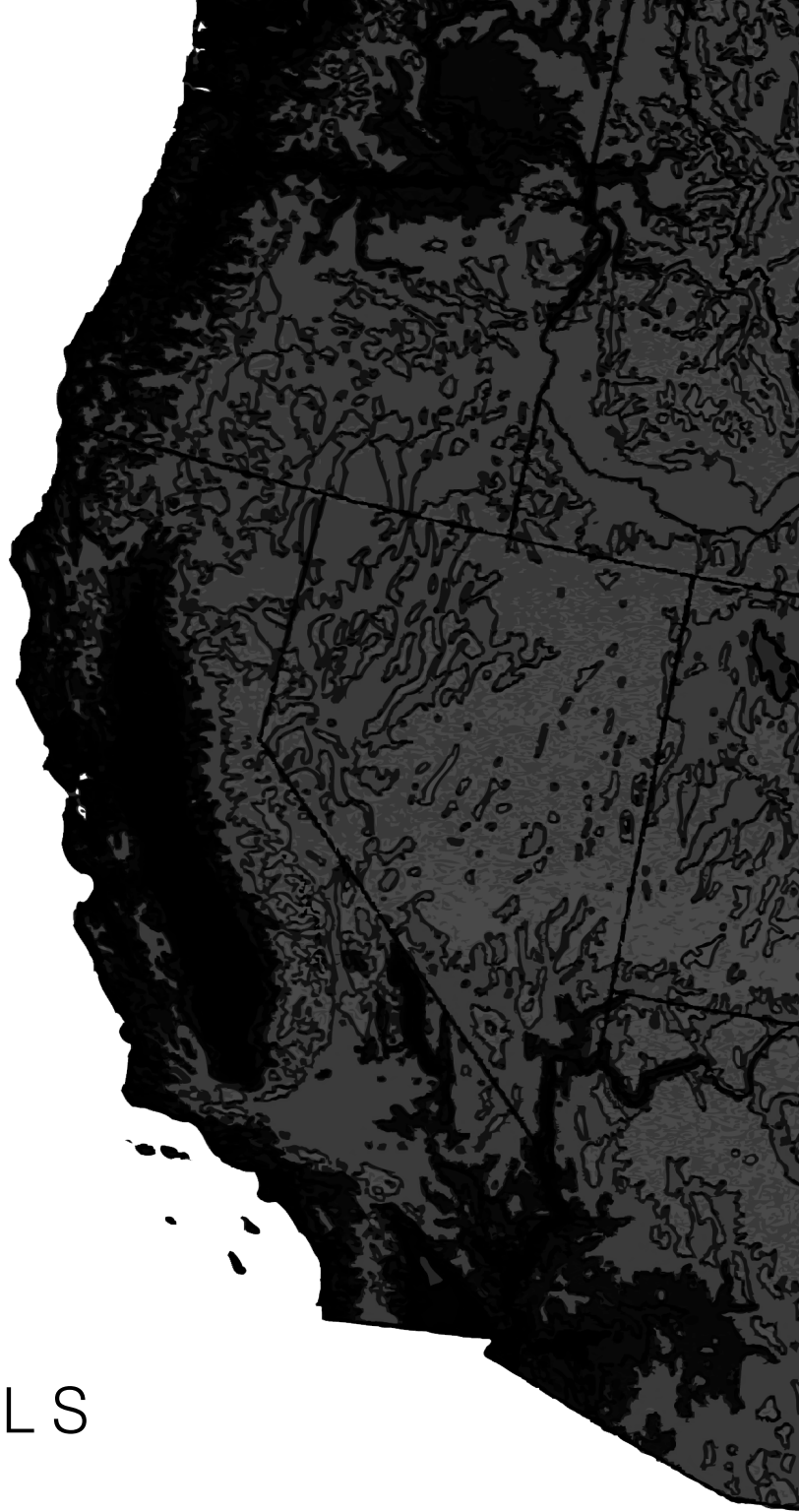
MUSEUM

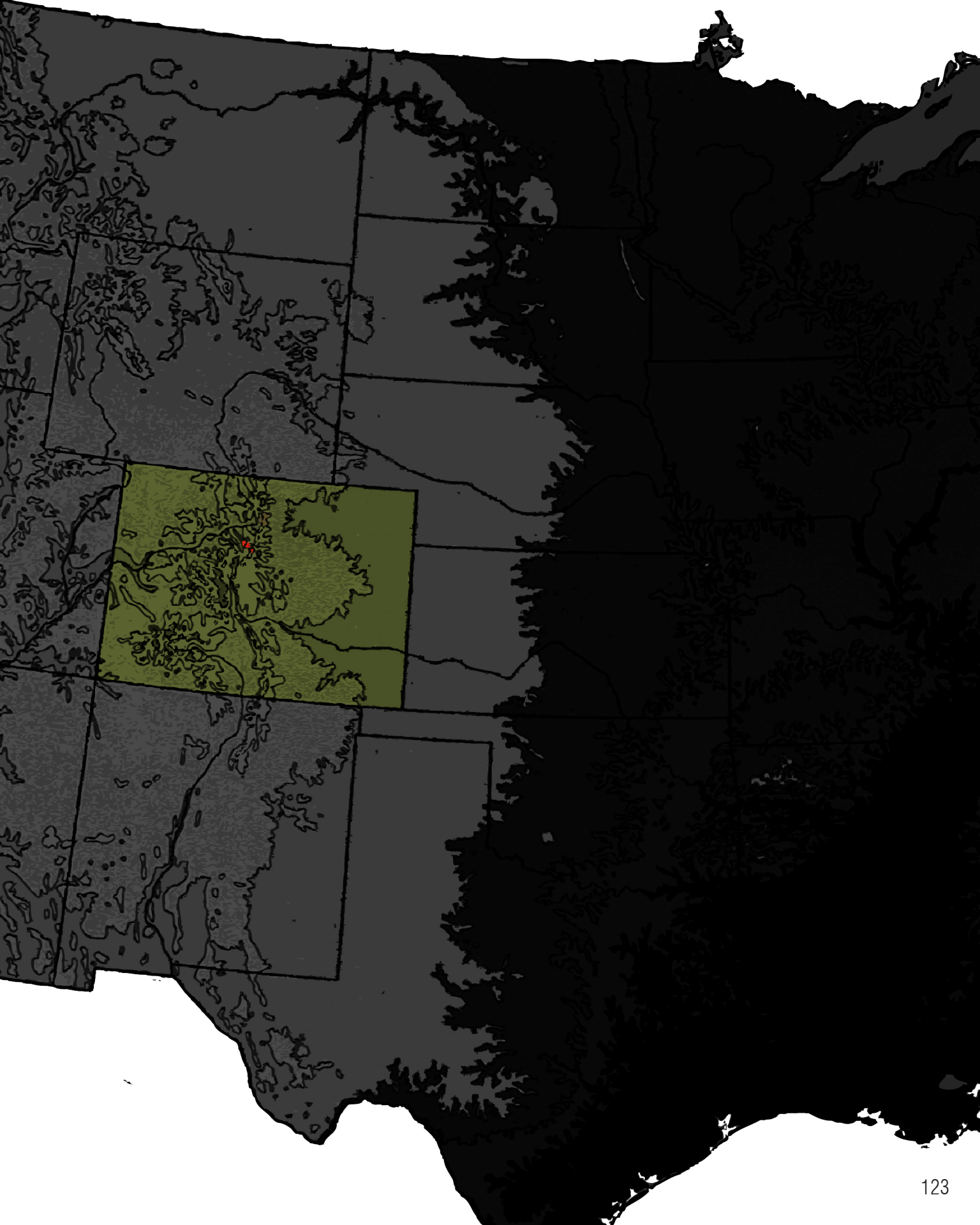
OF GEMS

METALS

AND MINERALS

GEORGETOWN COLORADO





My thesis, The National Museum of Gems, Metals & Minerals in Georgetown Colorado poses a simple question:

Is it possible to examine sustainability as both an experiential phenomena and a specialist's application of technology to a building?

Through research, I have found sustainability in architecture has become disconnected from experience, because it has been reduced to a scientific application of technology to a building. There must be some reconciliation between sustainability, culture, science, and especially experience. Such issues are important because relating to experience is the foundation of what architecture has always done. This is not to say that the technology should not be used. Rather simply, sustainability and the body are often unrelated due to the application of a formula to a building.

The problem, I believe, lies in the definition of the word.

Sustainability 2015:

Sustainability is the control of resources and energy in a reasonable manner yielding long lasting systems and processes which degrade the overall environment less than their counterparts.

When reading the definition there seems to be only positive ideas- Perhaps it's not purely the definition but today's culture being so apt to interpret it at its face value. Instead of seeing the definition as a symbol of a balanced lifestyle, people (especially architects) most often look only to technology to solve the problem instead.

Hans-Georg Gadamer would likely attribute it to modern thought's tendency to use science as the only basis for acquiring "truth". Perception, as defined by science, is no longer seen as a means to acquire truth, as the body and mind are too easily tricked. This way of thinking, Gadamer argued in his book "The Enigma of Health", has led to a world of specialists. Specialization in every single field of practice has led to a world where even people who are in the same field of study have no way to relate to colleagues studying topics barely different from their own.

Specialization occurs in architecture as well. Architects often specialize in using certain materials, systems, or technologies. Now, even to practice legitimate sustainable design architects must go through separate training and specific accreditation.(LEED) Even the programs used to create drawings vary greatly among different firms where often one person is deemed the specialist. The problem is not that the specialization exists - it is that the specialization is so often expressed in an unrealizable way through the architecture.



Figure 30.11 Hans-Georg Gadamer
<http://upload.wikimedia.org/wikipedia/commons/1/1d/Hans-georg-gadamer.jpg>

Hans-Georg Gadamer

1900- 2002

The Enigma Of Health

“The experience that can be validated as certain by the scientific method has the distinction of being in principle absolutely independent of any situation of action and every integration into the context of action.”

“Science makes possible knowledge directed to the power of making, a knowing mastery of nature. This is Technology. And this is precisely what practice is not.”

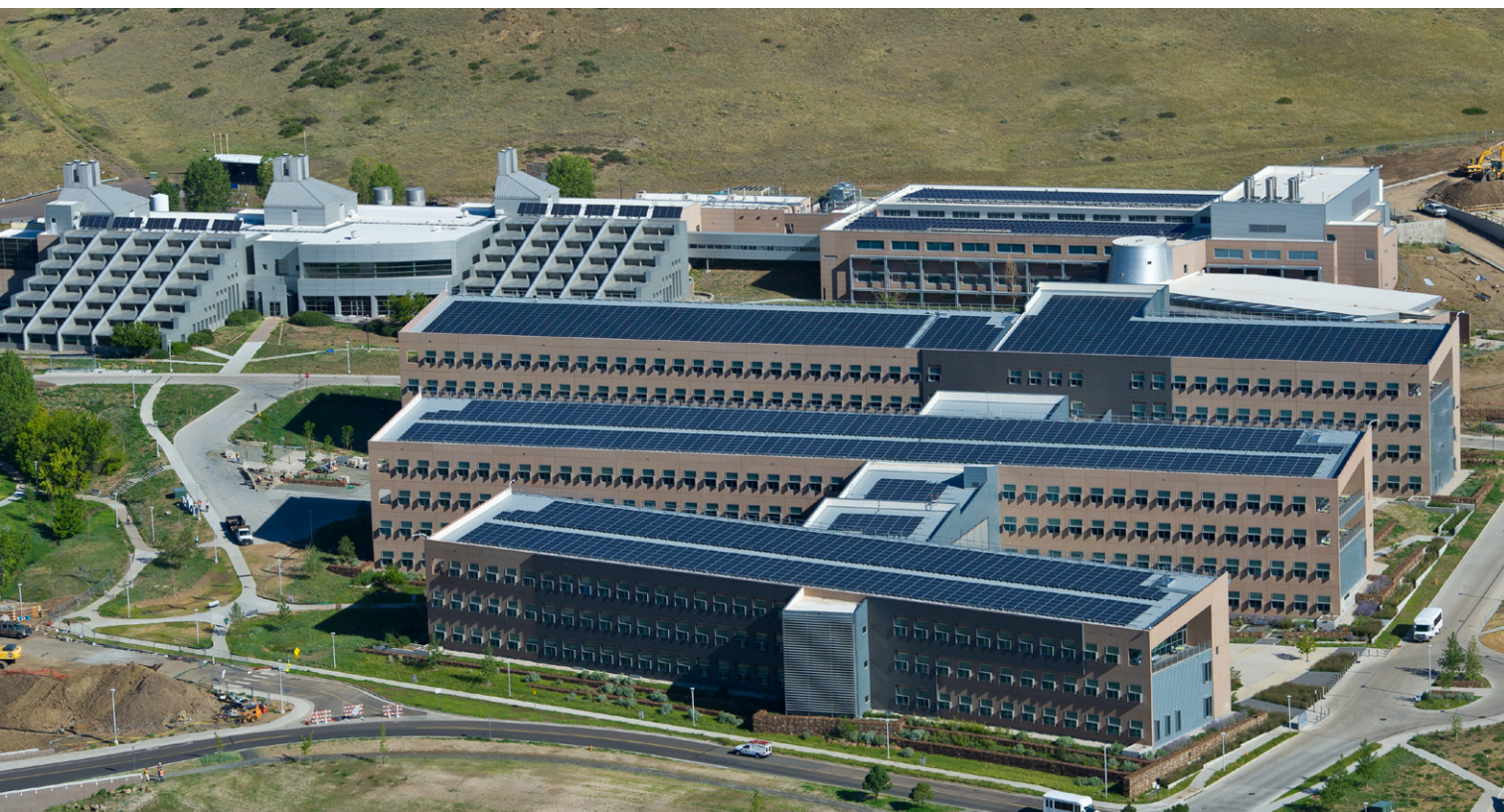
We live in a world where we interact with technology in some way nearly every minute of our daily existence. The common person though has no understanding how it truly works. We interact with computers, but how does the light hitting your eye generated by the photons flowing from the pixels on your screen truly form the letters that your hands are typing? From where are the electrons flowing through its circuits? If its hardware malfunctioned would you be able to fix it yourself? The common person has only the means to apply technology but so often has no way of knowing how it truly operates.

When this happens in architecture, it so often this leads to buildings where the average user's understanding of the system is reduced to rooftop solar panels or a ductwork exposed. The application of sustainable technology leads to buildings that have no relation to perceptual experience.

The technique in which we so often apply sustainable technology doesn't relate to anything beyond itself. This is opposite of what architecture has always been about in that Architecture has always related to historical, social, and cultural context through the experience of the body.

Thus, what follows is an introduction to *The Myth of Sustainable Culture*; or more precisely, the lack thereof.

Figure 30.12 NREL Campus Photos.
<http://www.archdaily.com/443969/national-renewable-energy-laboratory-smithgroupjlr/>



Historically medicine and chemistry (then Alchemy), mathematics, painting, sculpting, and architecture all related in a similar way to: one another, culture, the body, and perceptual experience. According to James Elkins in his book "What Painting Is", Alchemy in particular focused on the "dyad" which was the duality of male and female, light and dark, hot and cold, fire and water, and the earth and air to describe the harmony of existence.

In this image of alchemical relationships one can notice the origins of sustainability. The sun, moon held in the hands of humans and gods connected to the earth were linked by the firm chain of the cosmos to the elements. The cosmos connected to the humans are also connected to nature (the trees) the three highest on the hill and most prominent being the signs of sexuality and purity ((That, being) the dotted central oculus denoting gold). The overall essence of the image speaks of the balance of opposites and the harmony achieved through alchemical existence. This is very different from chemistry and medicine today in that they are both purely objective and specialized ways of interpreting the environment described through a means of things that are not perceptible or relevant to experience. Alchemy was not simply a manner of documenting chemical relationships such as chemistry is today, but rather a means of revealing and actually as a means of dwelling.

Figure 30.13 Image of Alchemical Cosmos.
http://www4.ncsu.edu/~kimler/hi322/alchemical_cosmos.jpg

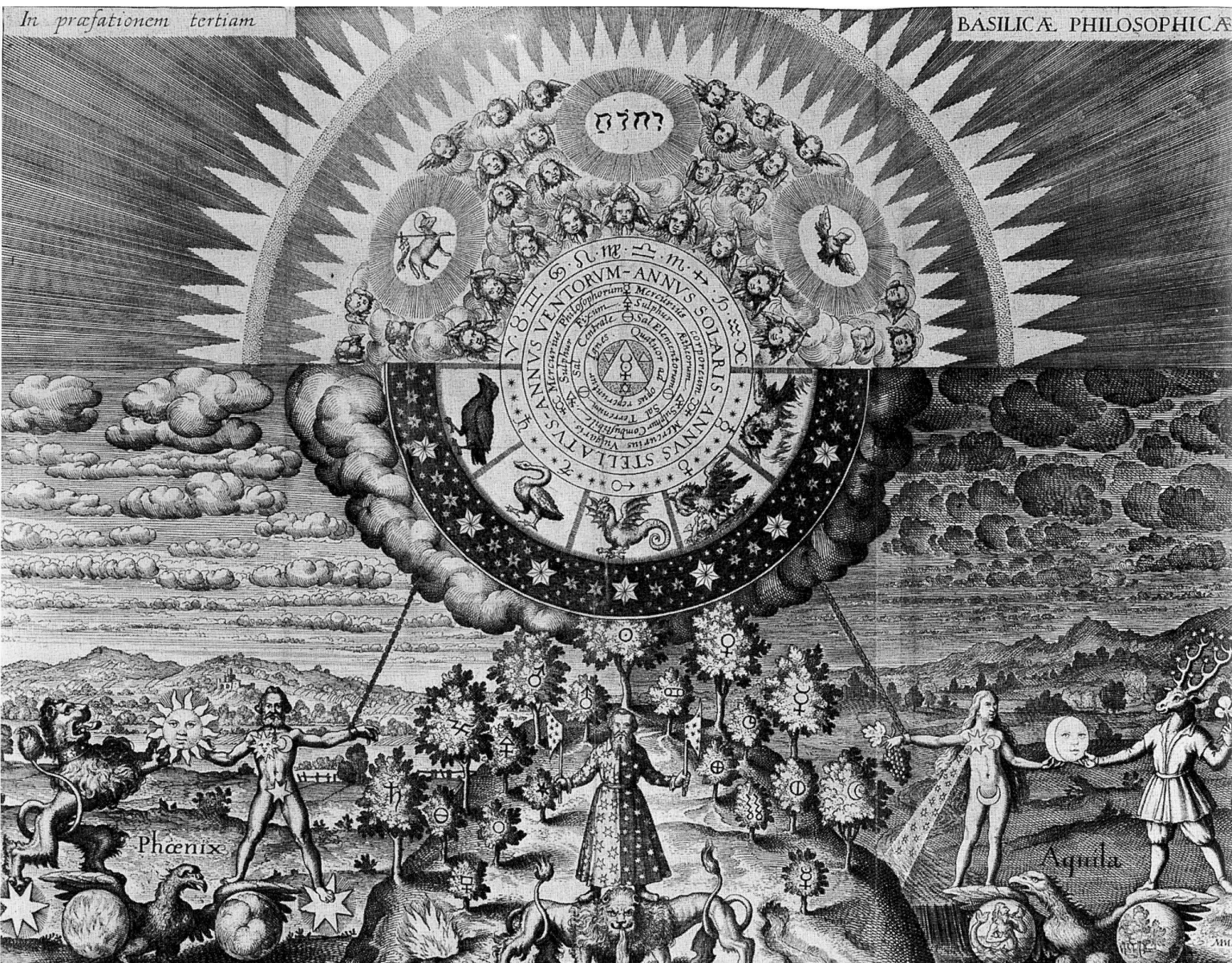




Figure 30.14 Martin Heidegger
http://i.telegraph.co.uk/multimedia/archive/02877/heidegger426x536_2877455a.jpg

Martin Heidegger

1889-1976

The Question Concerning Technology

Building, Dwelling, Thinking

Fourfold

Harmony in human perceptual experience alongside the earth, cosmos, and indefinite culture.

Bridge Metaphor

The river's banks only reveal themselves under the bridge which spans them.

Technological Reduction

"Truth" reduced to scientific analysis. Perception is no substitute for scientific knowledge.

Similarly in the modern context, Martin Heidegger defined sustainability in the terms of dwelling. Rather than mythically, Heidegger spoke of dwelling within the fourfold; humans, the earth, cosmos, and the eternal life of culture as a means to unity and harmony similarly to the encyclopedic definition of alchemy. By so doing, Heidegger has dominated the talk of sustainability in that he was the father of the modern context which rooted from alchemical ideas.

O n D w e l l i n g

“Mortals dwell in that they save the earth... Saving does not only snatch something from danger. To save really means to set something free from its own presencing. To save the earth is more than to exploit it or even wear it out. Saving the earth does not master the earth and does not subjugate it, which is merely one step from spoliation”

-Martin Heidegger



Figure 30.15 Luca Pacioli
[http://upload.wikimedia.org/wikipedia/commons/1/16/Luca_Pacioli_\(Gemaelde\).jpeg](http://upload.wikimedia.org/wikipedia/commons/1/16/Luca_Pacioli_(Gemaelde).jpeg)

Similar corollaries can be noted in historical mathematics. Pacioli, who is renowned for his work with the golden ratio in relation to the body, believed in a unity of mathematical sequences and geometries similar to the dual nature of the Alchemical system. In Alberto Perez Gomez's writing "The Glass Architecture of Fra Luca Pacioli", Alberto notes how Pacioli's goal was to demonstrate the notion that mathematical numbers in both theory and practice are related to the divinities and a divine numbering system. He was guided by the idea that our numbering system was a broken system of dualities that were once divine numbers, and that geometry was the primary means of demonstrating the "monad" which he defined as all that is good, desirable, and essential. The dualities of the numbering system that Pacioli described were similar to the alchemical beliefs of the balance of opposites, and the dual nature of existence known as the dyad. With the circle being the most pure form of linear geometry, Pacioli found that the Icosahexahedron in the top left of the painting was the purest form of three-dimensional geometry. This is because the perimeters of a square and triangle inscribed in a circle yielded a ratio of 1:1.618, That is, the golden ratio found throughout the natural world numerically described by the Fibonacci sequence.

Looking to history - nature, mathematics, science, art, and architecture all had common grounds of dialogue, and were all related to the material of the earth, and the ethereal immaterial of the cosmos. The icosahexahedron in the painting half filled with water resides in a duality of being both solid and opaque, tangible yet ethereal, lit... yet a transmitter of light itself. The nature of the object is that of a similar nature of a perfect gem which has been refined into its purest essence.



Figure 30.21 Saint Denis
<http://www.thousandwonders.net/Cathedral+Basilica+of+Saint+Denis>

Immateriality and materiality have been noted architecturally in Jason Crowe's work "The Sacred Stones of Saint Denis". A cathedral unlike any other Light perceived cast on the sacred stones is related to the foundations of ethereal alchemical transformations as well as mathematics, or even the painting of Pacioli and his isocahexahedron. The same can be said about the ethereal combination of energy and chemicals in modern chemistry. The cathedral of Saint Denis is renowned for being a sacred pilgrimage because the purity of light entering the cathedral has been historically noted as being unlike any other. Abbot Suger who is known as being one of the earliest patrons of Gothic Architecture born in 1081 noted that the light in the cathedral falling on the stone was the truly the bridge between material and immaterial, the revealing bridge between the mortal realm and the heavens.

The cathedral has been described as a gem in the realm of gothic architecture. It was said by Hildegard of Bingen in the early 12th century that "the power in stone comes from the fire that it contains." This statement of Alchemical origins describes what can still be seen in modern day stone, particularly gems. The refinement of light can be seen metaphorically related to sustainability in so far as the refinement of light in the cathedral is similar to the refinement process which a gem undergoes, in that sustainability is a refinement of culture in the same regard.



Figure 30.22 Peter Zumthor's Bruder Klaus Chapel.
http://www.archile.ct/zumthor_capilla03.jpg

Similar qualities can be noted in a building such as the Bruder Klaus chapel by Peter Zumthor. In the modern context, Zumthor merged the experience of the building with the cosmos through light and the power of its refinement. When compared to Saint-Denis, the experience is totally the polar opposite, in that it limits the light in a very particular manner rather than flooding the space with revealing light. The idea though is similar.

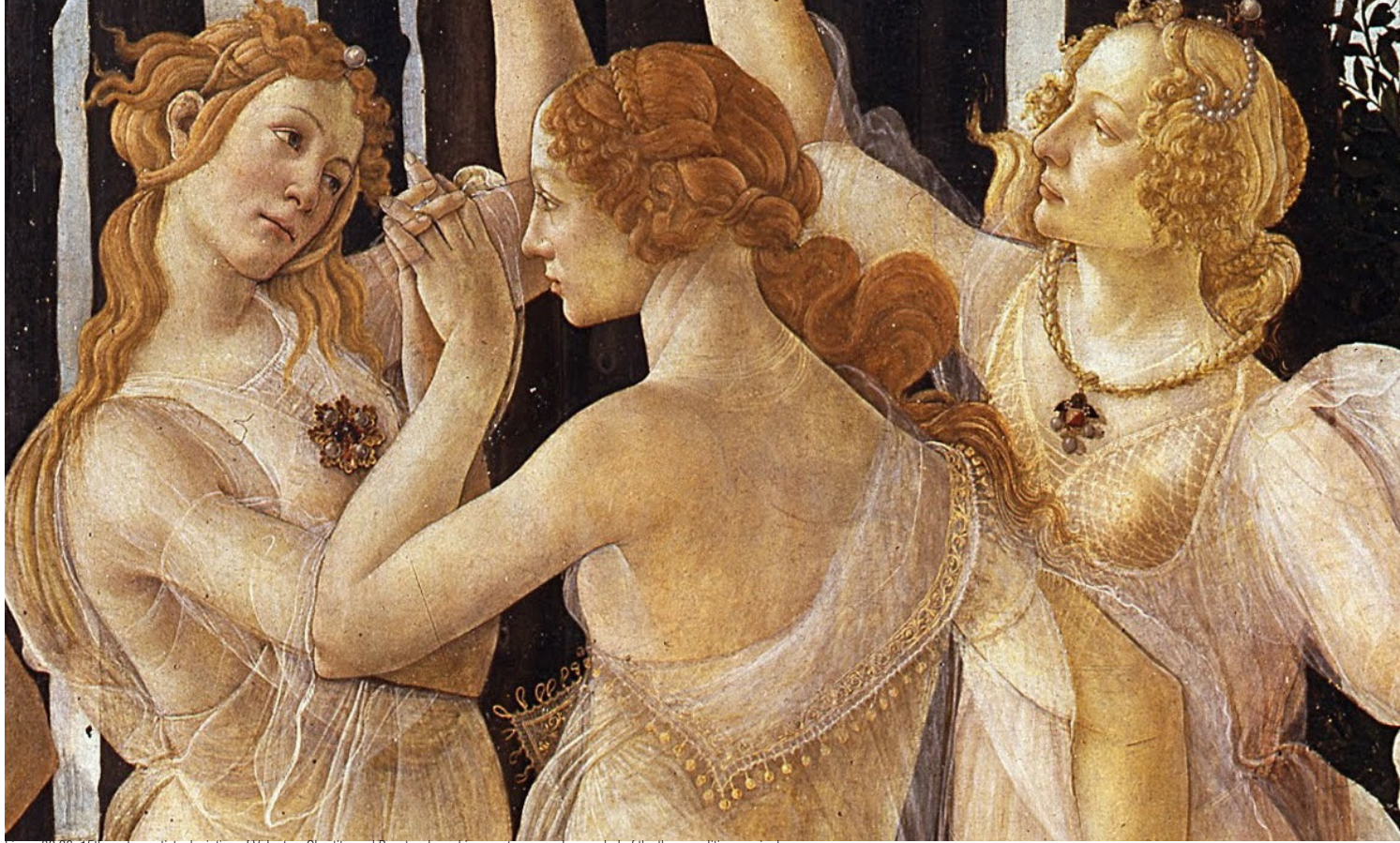


Figure 30.23 15th century artists depiction of Voluptus, Chastity, and Beauty adorned in rare stones; each a symbol of the three qualities required for pure attraction and seduction. <http://3hourspast.files.wordpress.com/2013/08/three-graces-clothes.jpg>

The beauty of the gem is that which is, as noted earlier, that which comes through the fire which the gem contains. A gem holds the power, similarly to the Daidala of myths past, to truly affect the presence person wearing it. The addition of a single gem to a person's body can define marital status, social class, personal taste, or attractiveness.

Alberto Perez Gomez noted in "The Myth of Daedalus" that "The architecture of today is overshadowed by diverse demands and complex technologies. Historically the architect's primary duty was to engage the public realm not unlike the sculptor or painter." Architecture has always been about relating the body and experience to the greater continuum of culture. One could argue that sustainability can, and should do the same. My thesis examines this relation through the use of gems. Through their craft, gems create a seductive presence which truly affects the place around them. This presence is similar to what architecture and art has always done: It creates a space of participation between the user and the object open to an interpretation.

Alberto Pérez Gómez

1949 -

Built Upon Love

The Myth of Daedalus

The Glass Architecture of Fra Luca Pacioli

“The architecture of today is overshadowed by diverse demands and complex technologies. Historically the architect’s primary duty was to engage the public realm not unlike the sculptor or painter. The architect today though should be able to acknowledge this complexity and relate to the ever important cultural relevances relating to love, desire, and compassion on which architecture is built.”

The Artefact

An artefact is an architectural representation of an idea that goes beyond standard modeling and drawing to evoke a presence in real space and time.

The artefact I created consists of elongated wooden rods, each balanced on one another and suspended by a single thread. The last equalizer of the balance is a pure lens of ice which is seen in pure white in this photo.

The artefact presents what is possibly the most delicate setting of a gem. The grains of the wood evocative of the layering of the earth contrast the layering of shadows on the floor below. The balance achieved is evocative of a sustainable existence. The pure lens of frozen water, the lifeblood of existence, slowly dwindles and will eventually disintegrate, evaporate, and be reabsorbed into the natural order of the earth. If left unchecked by human touch the system will collapse, and the equilibrium achieved will be lost.



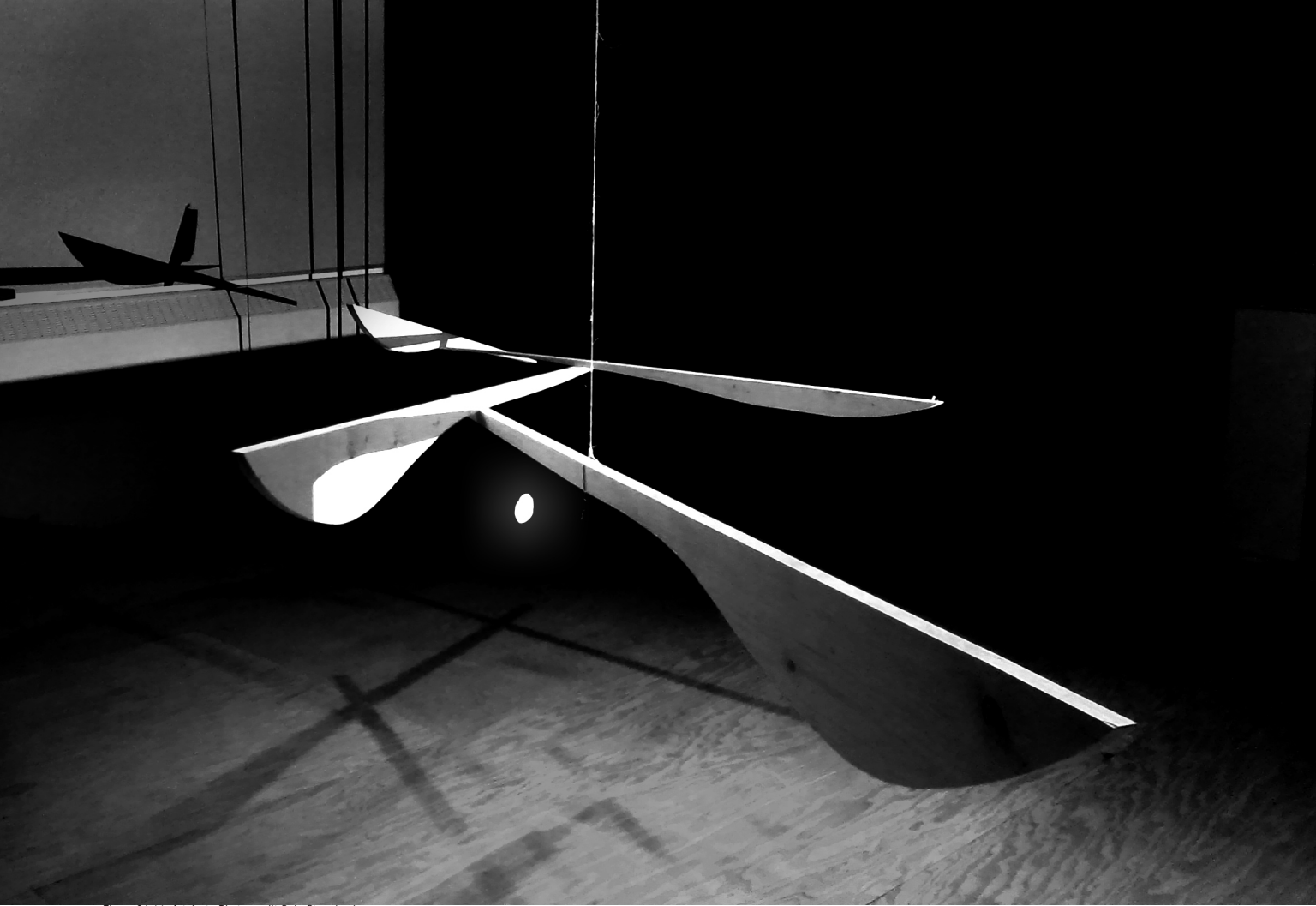


Figure 31.11 Artelact. Photo credit Cole Strombeck.

The Site: A Brief Re-Introduction



Figure 32.11 Historic Georgetown Photo. http://www.onlycolorado.com/Colorado_Photos/georgetown_from_above.php

Georgetown, Colorado was, for eighty years, a destination for the silver seekers of the Pike's Peak Gold Rush commencing in 1858. The city then was a much different place than the laid back natural paradise that it is seen as today. In those days people of all different temperaments, talents, and convictions were drawn to the place by their similar obsession with gold, silver, and other fortunes. For eighty years the people of the city saw the earth as a bridge to their own fortune. For eighty years the dwellers unanimously concluded that the earth should be seen as nothing but standing reserve. On the eightieth year after the town's inception it was instantaneously dissipated in the same fashion of its creation due to the lack of thought and precedent leading to its undoing, and due to the ironically illustrious greed of its founding.

The city is now sustained through the natural beauty of the place; the final sustenance allowed by the earth.

Figure 32.12 Georgetown. <http://www.humanityhiker.com/wp-content/uploads/2011/09/DSCN3145Web.jpg>



Figure 32.13 The Site. Photo credit myself.



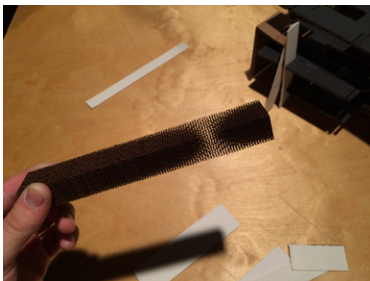
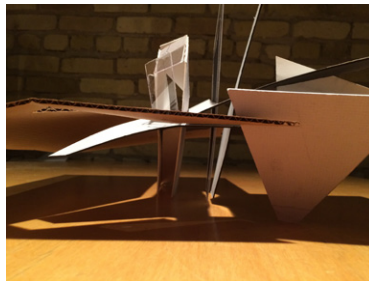
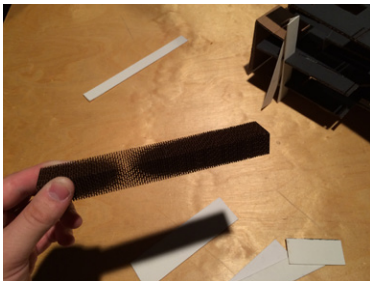
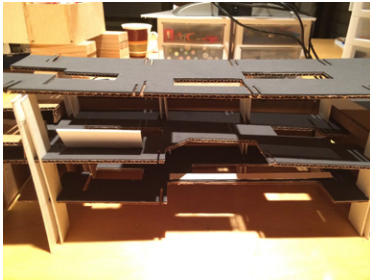
Looking north of the site lies Georgetown Reservoir, its pure mountain runoff shimmering and reflecting the towering mountains surrounding. To the south, an endless river of crushed quartz, and an inverse mountain in the clouds.

Design Process Models



Early process models explored opportunities of delving underground and how light can be brought in to subterranean spaces. Through model material experimentation, ideas such as permeable walls, light cannons, and different layering techniques were explored.

Figure 33.11 Process Models.



Building circulation was eventually resolved into a switchbacking of stairs and ramps which can be noticed in parts of the final design.

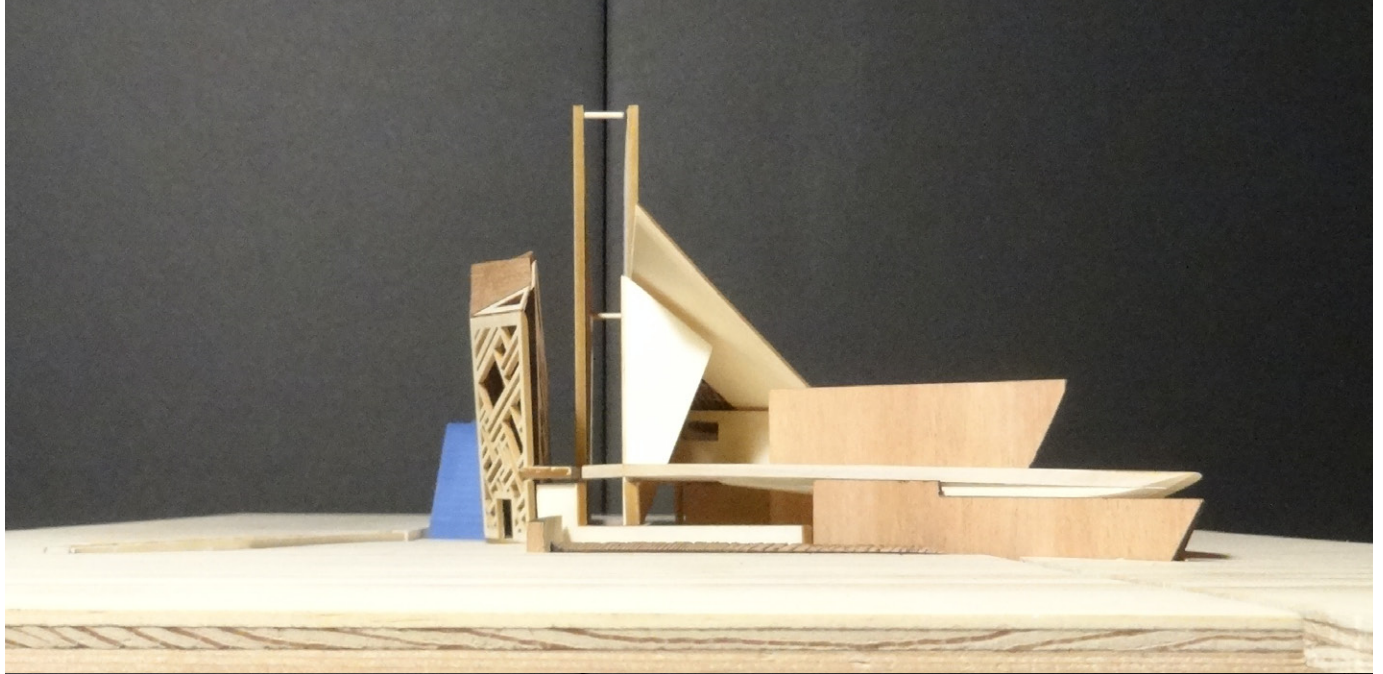
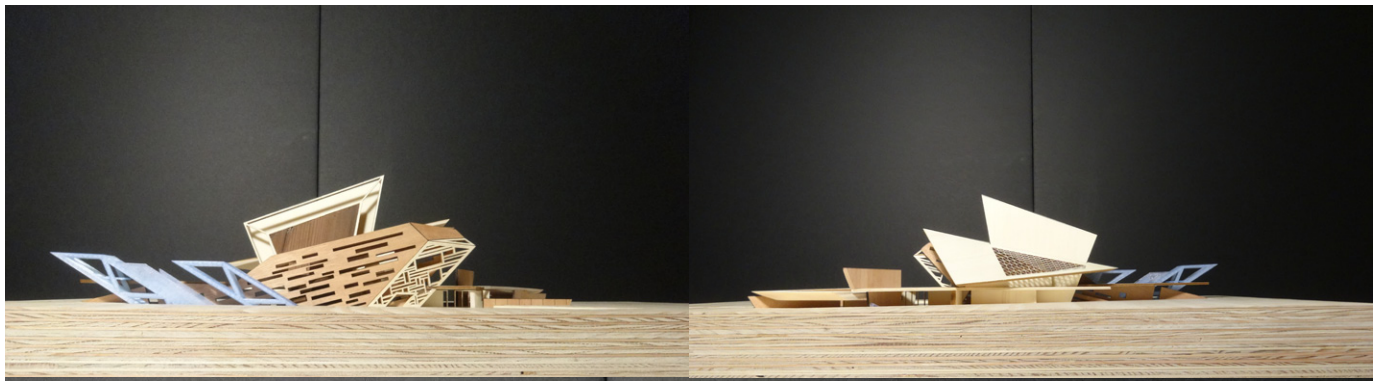
34.0

Final Model

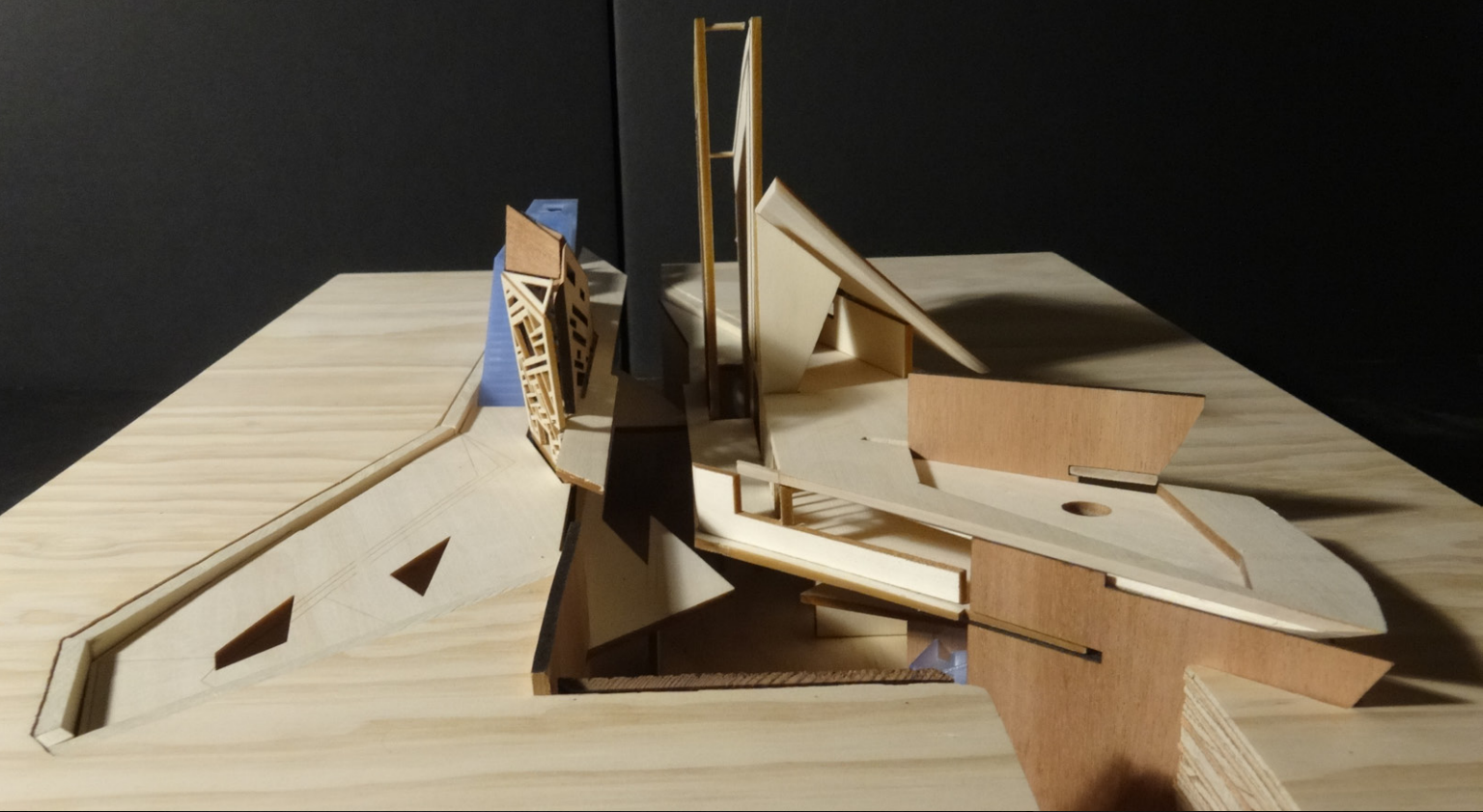


Figure 34.11 Final Model.

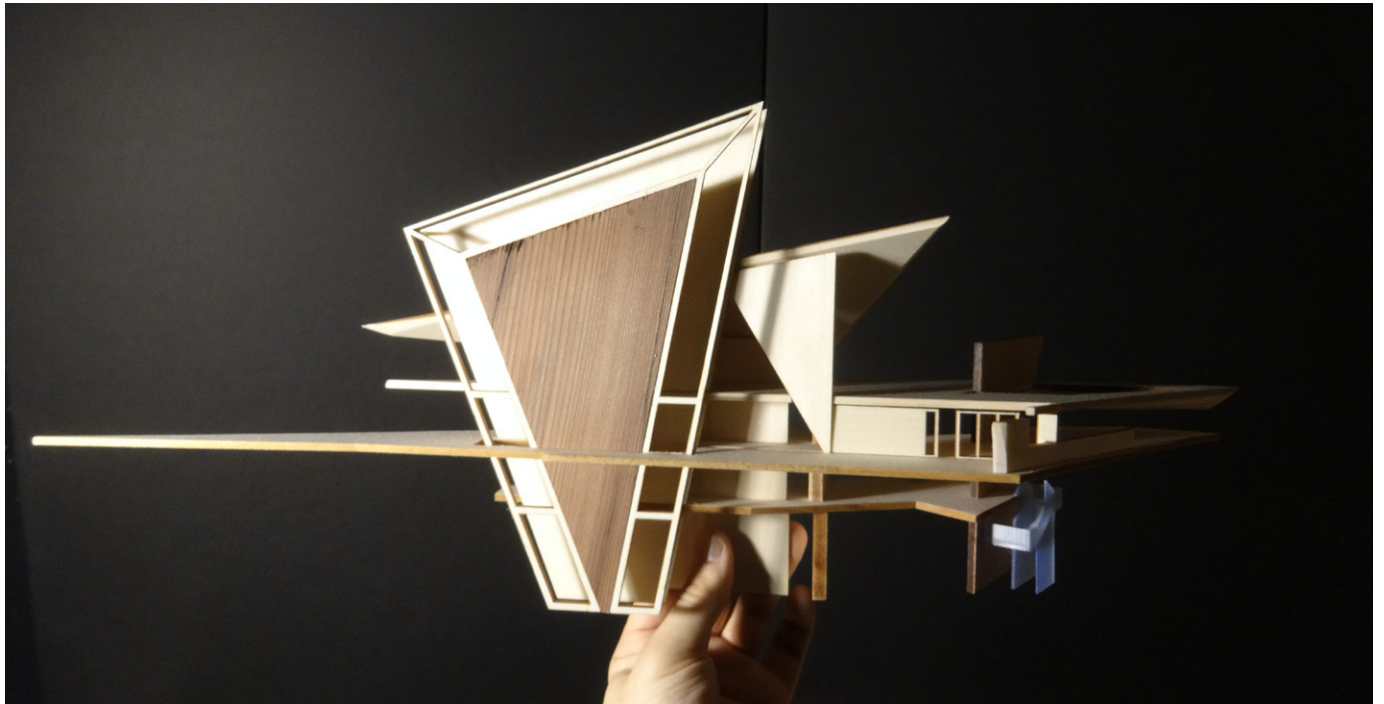
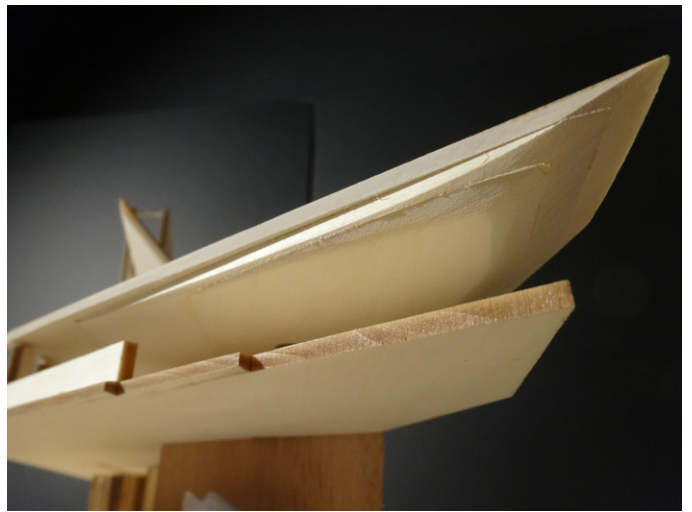
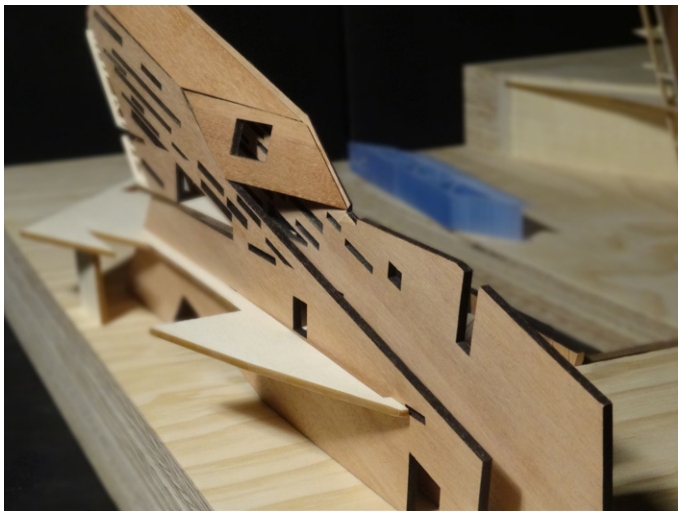
















Deep within the ravine of the Rocky Mountains, the building is a bridge between the towering stone surrounding and the ground-zero of Georgetown Reservoir.

A shattered gem, the architecture ironically speaks to the un-sustainability of mining gems, becoming a hollowed pit filled with the illustrious beauty of the shimmering infinitesimal. The building is suspended over the Georgetown Reservoir, on axis with the tip of Silver Plume Mountain to the west.

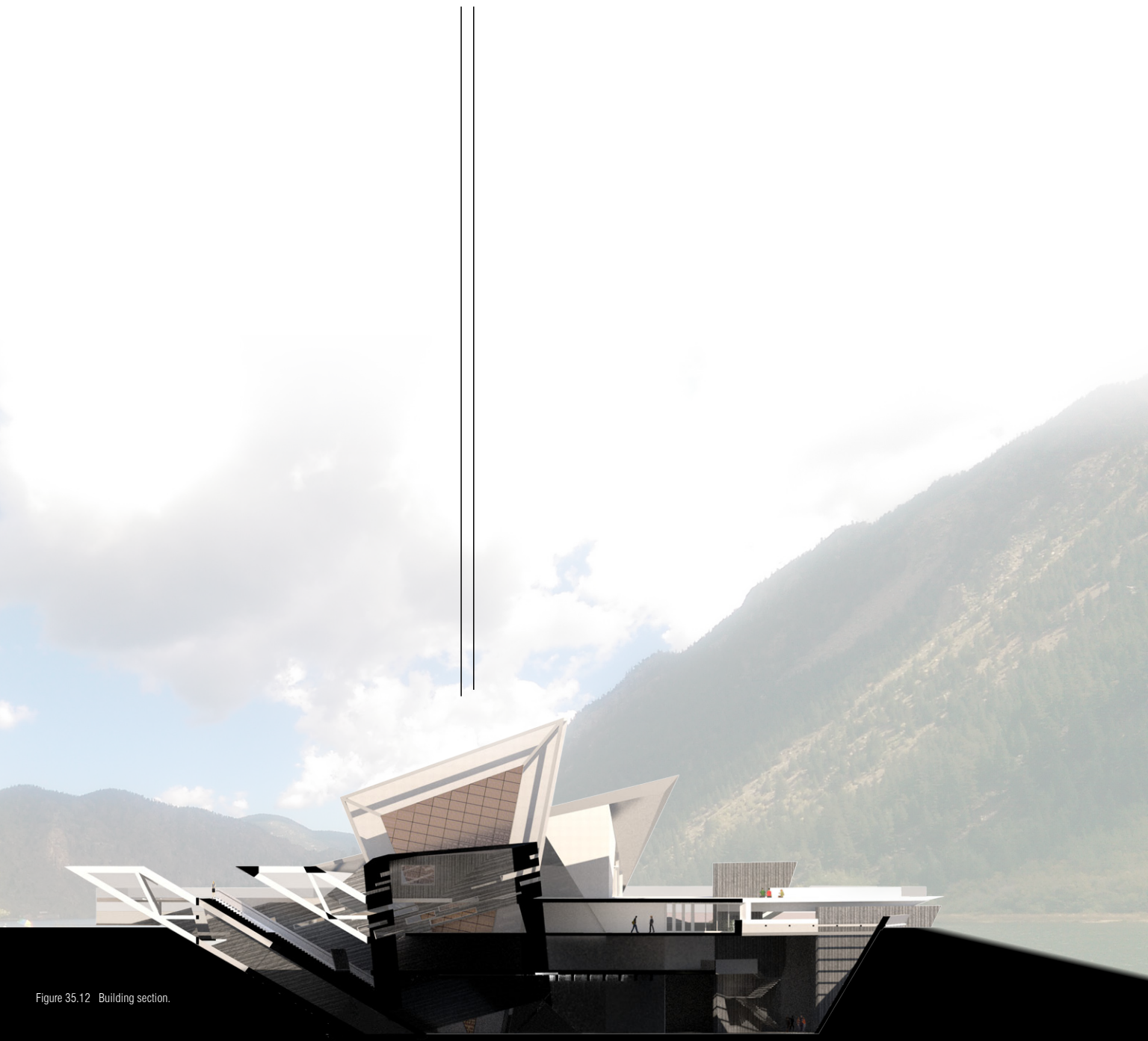


Figure 35.12 Building section.

- 9 ROOFTOP PATIO
- 8 CAFE / SHOP
- 7 EXTERIOR CAFE SEATING
- 6 SKY GARDEN

- 5 EXPOSED INTERIOR DISPLAY
- 4 EXPOSED INTERIOR DISPLAY
- 3 LAKE FRAME
- 2 FUNICULAR ELEVATOR ACCESS
- 1 RECEPTION

- 0 BUILDING ENTRY
- 1 EXPOSED INTERIOR DISPLAY
- 2 ADMINISTRATION / SECURITY
- 3 LIGHT WELL CORRIDOR
- 4 EXPOSED EARTH DISPLAY
- 5 GROUND / -2 FLOOR ACCESS
- 6 GROUND / ROOFTOP ACCESS
- 7 GEOTHERMAL DISPLAY AREA
- 8 CUSTODIAN CLOSET
- 9 WOMEN'S WC
- 10 MEN'S WC

- 11 SKY FRAME
- 12 WAVE WELL
- 13 MECHANICAL LIGHT WELL
- 14 FUNICULAR ROOM
- 15 BUILDING MECHANICAL

The fragmented plan of the building was achieved through an experiential interpretation of space. The divided bridge is designed to disorient the users, only to reorient them through frames of the sky, earth, lake, and surrounding mountain peaks.

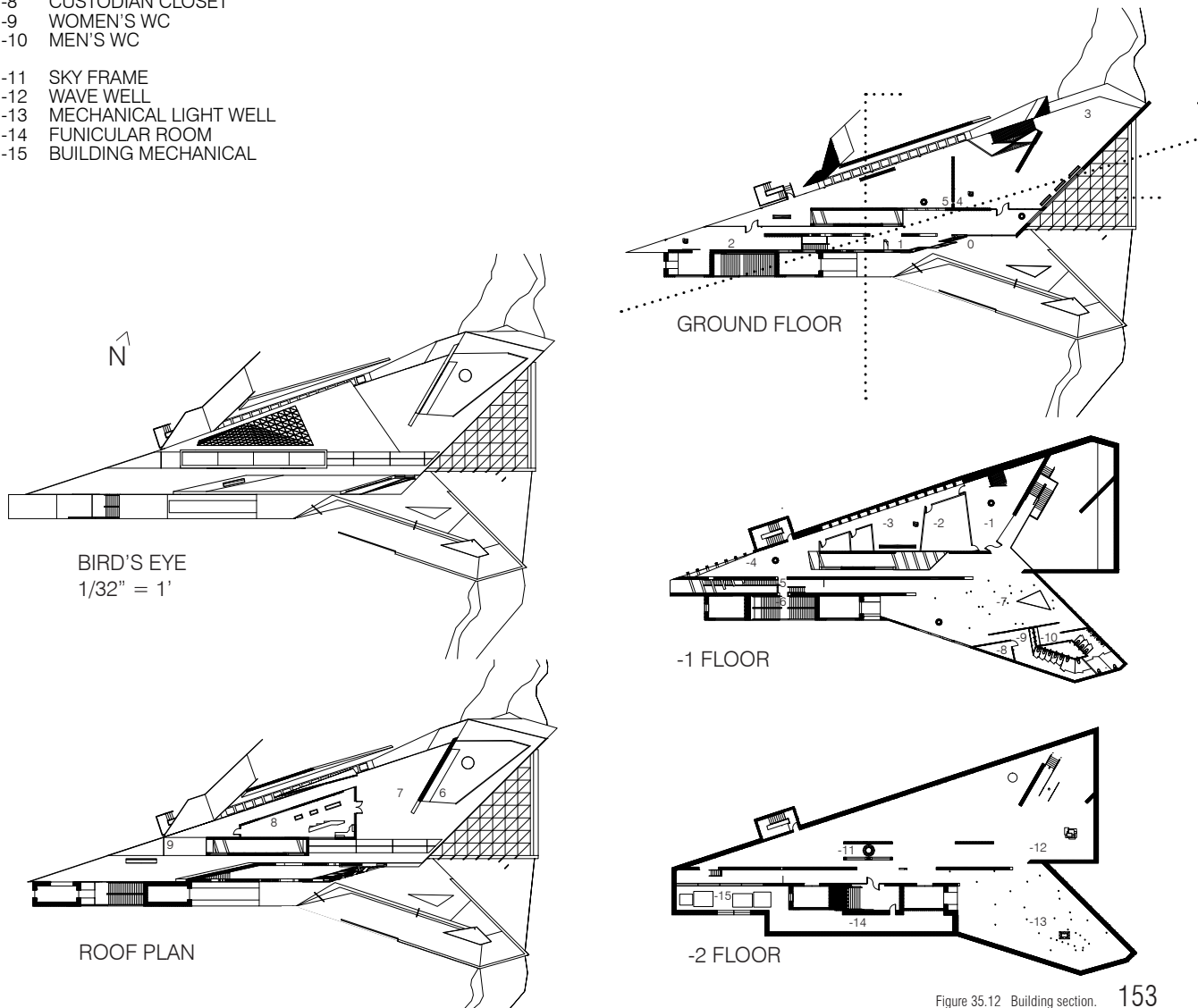


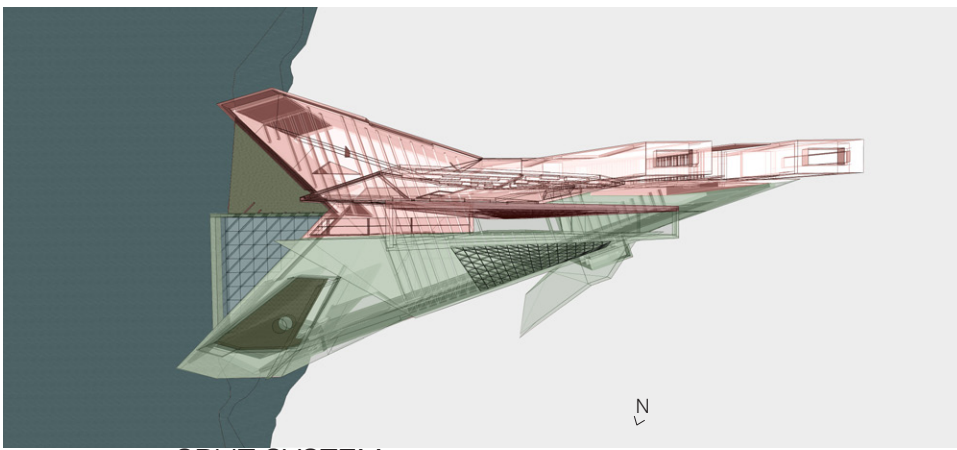
Figure 35.12 Building section. 153



Figure 35.14 Building section.



A dyad, the museum is split into two halves down the central mediating wedge. This allows for an instant of clear line of sight through the building when approaching from the east or west; revealing the dual nature of the building's system.

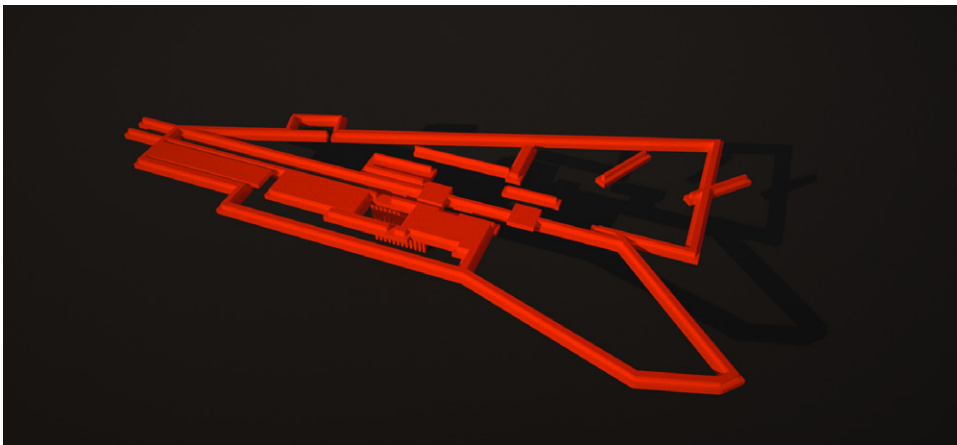


SPLIT SYSTEM

Figure 35.15 Split System

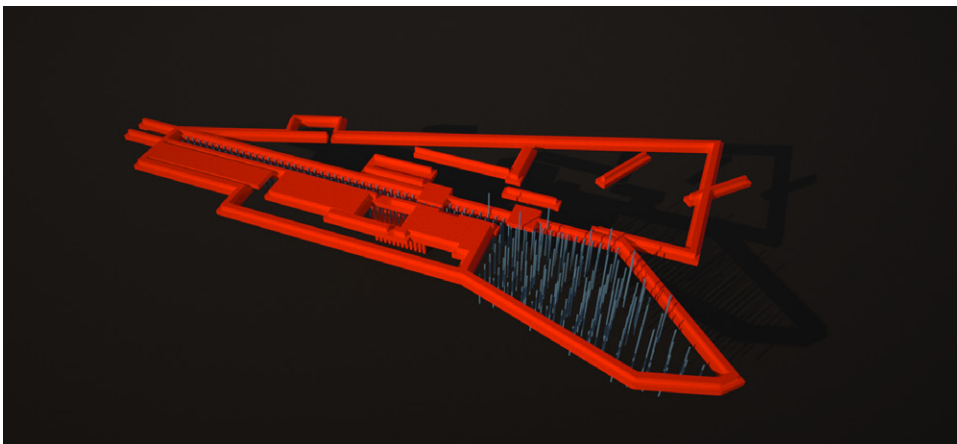
The southernmost half of the museum showcases sustainable technology as an experience, while the northern half is much more primal - oftentimes exposed to the elements and uses solely passive systems. The experience leads to moments where one is in a constant overlap between the elemental and the controlled. Each moment an alchemical process, revealing the distance between sustainability and the body, the elements and experience.

Figure 35.21 System Diagrams.



FOUNDATION

The building uses multiple structural techniques including bearing walls, steel columns, and thick retaining walls to keep the surrounding elements at bay.

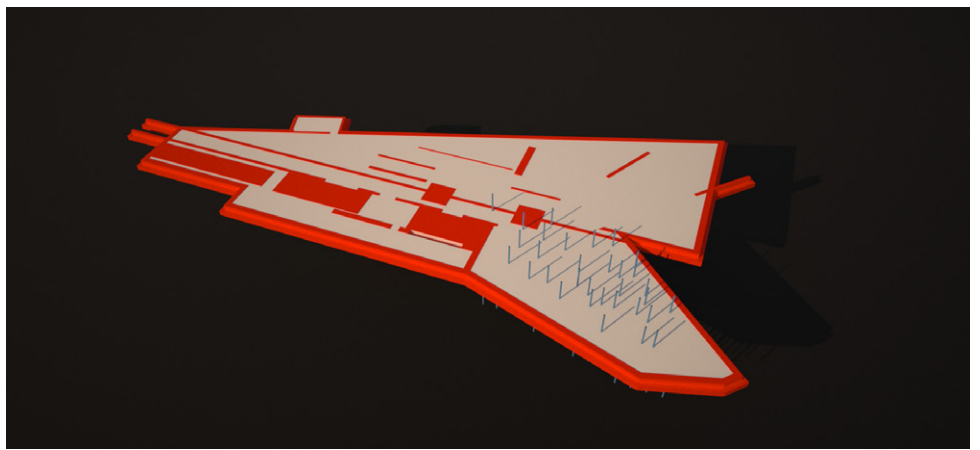


FOUNDATION GEOTHERMAL

Since the building is largely underground, much of the earth's thermal mass is taken advantage of to keep temperatures regulatory. Geothermal heating is used on the southern side to further regulate the building environment.

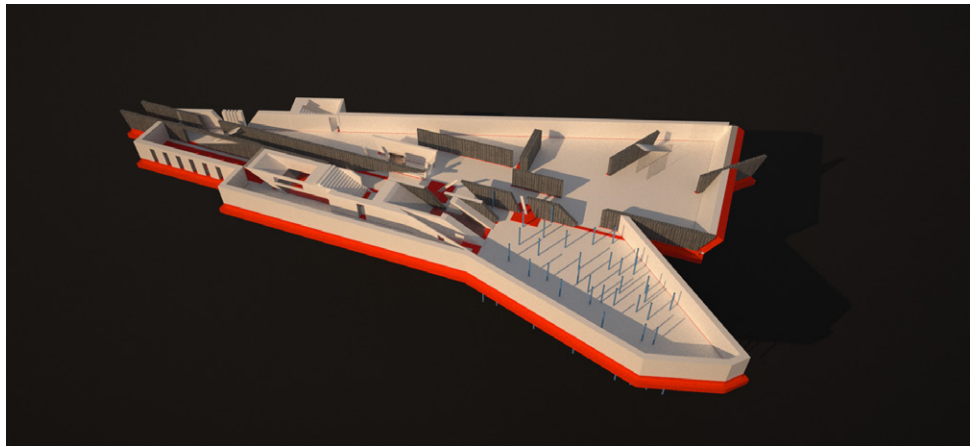
FOUNDATION GEOTHERMAL SLAB

Some of the rods for the geothermal heating penetrate through the slab of the floor - the idea being that if temperatures are variable, people will be able to feel the mild temperature difference when wandering through the field of columns through their sense of touch.



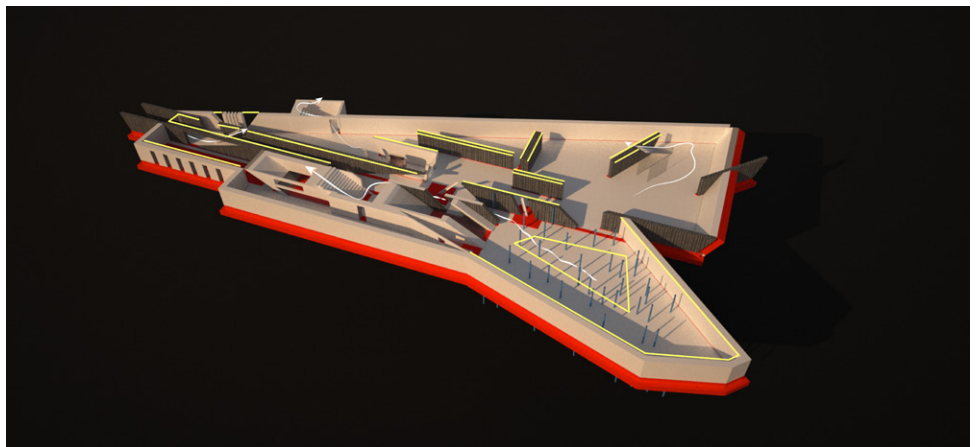
FOUNDATION GEOTHERMAL WALLS

The darker bearing walls in the image are made of site-cast, vertically board-formed raked concrete, while the white painted walls are cast in place concrete with the boards running horizontal. The of the layers of concrete is a reference both the artefact, and to the layers of the earth which is exposed in parts of the building.



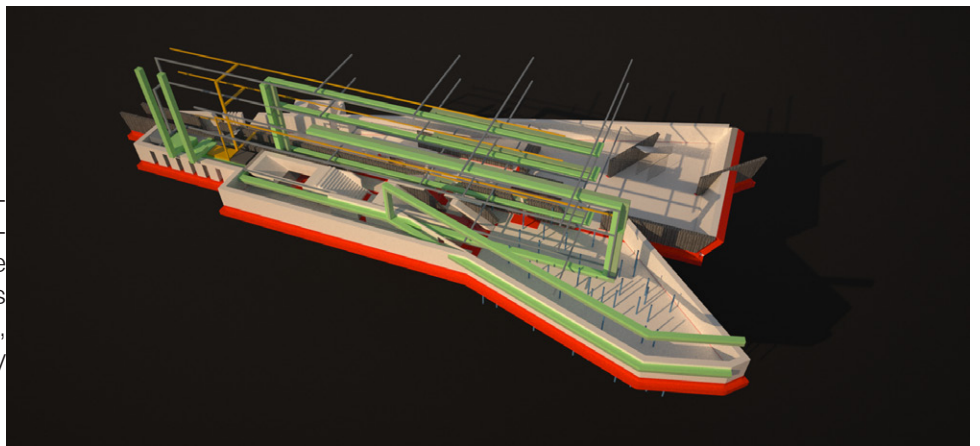
FOUNDATION GEOTHERMAL EGRESS LIGHTING

The type A-4 Occupancy building is of type 1 construction-being made of purely fully the noncombustible materials concrete, steel, glass, and earth.



FOUNDATION GEOTHERMAL WALLS TECH

The building mechanical runs between floors, occasionally wrapping through a visible area of the building. The major duct chase is on the south side of the building, running through a light well directly below the building entry.



THERMAL CHIMNEY

The mediator for the north and south side of the building is the thermal chimney. The glass on top, and at each floor opens mechanically - allowing the ancient sustainable technology to circulate air by way of natural convection. A section of the northeastern corner of the building is entirely exposed to the elements, allowing the cool lake air to flood in during the summer months.

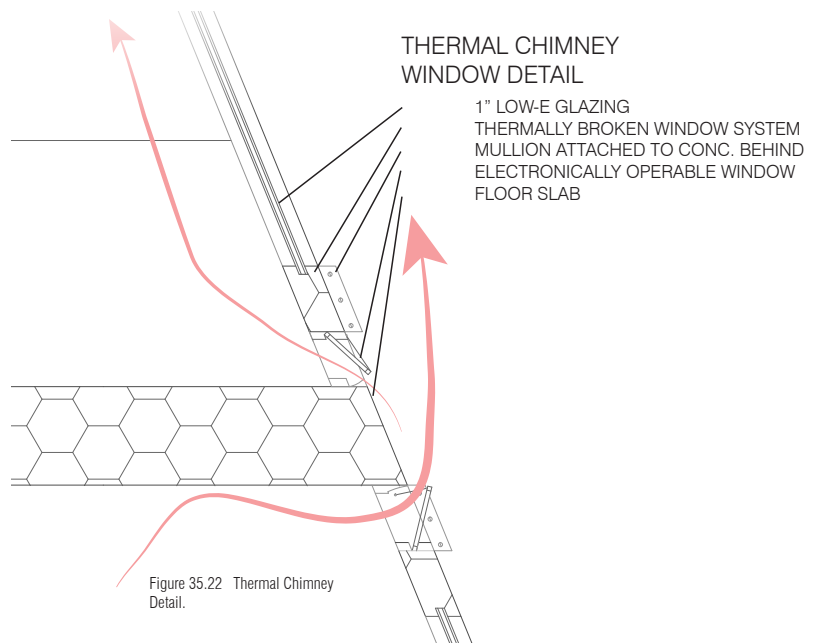
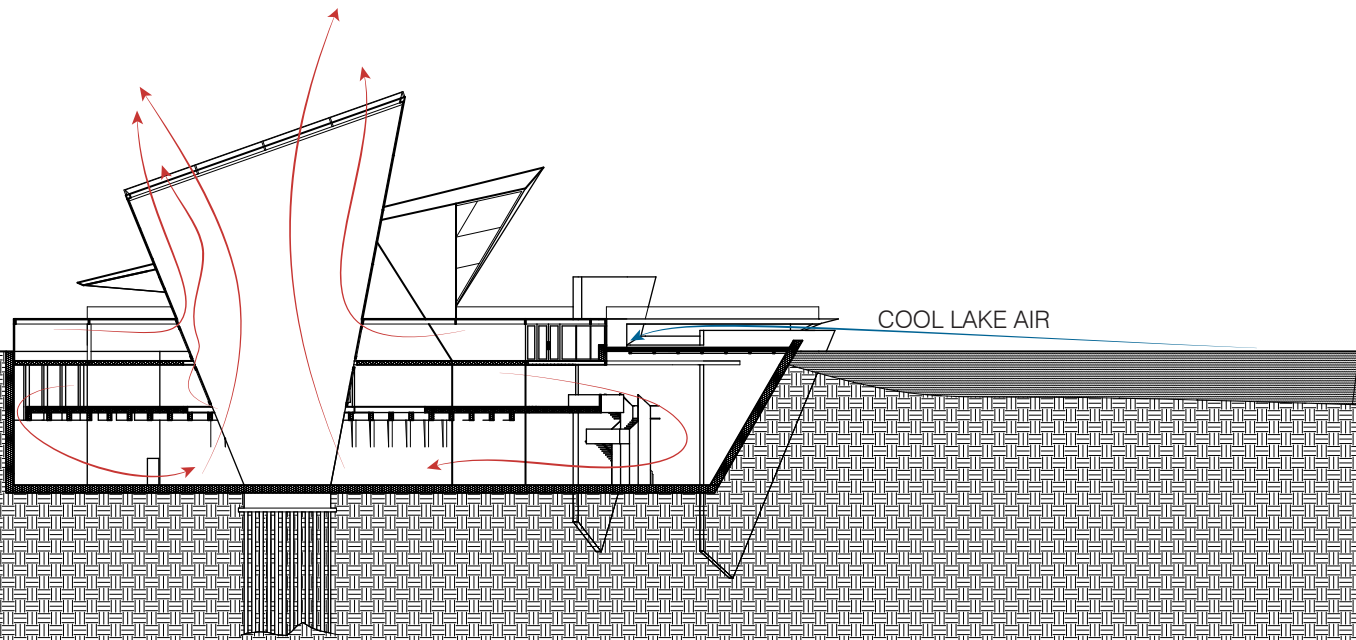


Figure 35.23 Thermal Chimney Diagram.



SOLAR GAIN

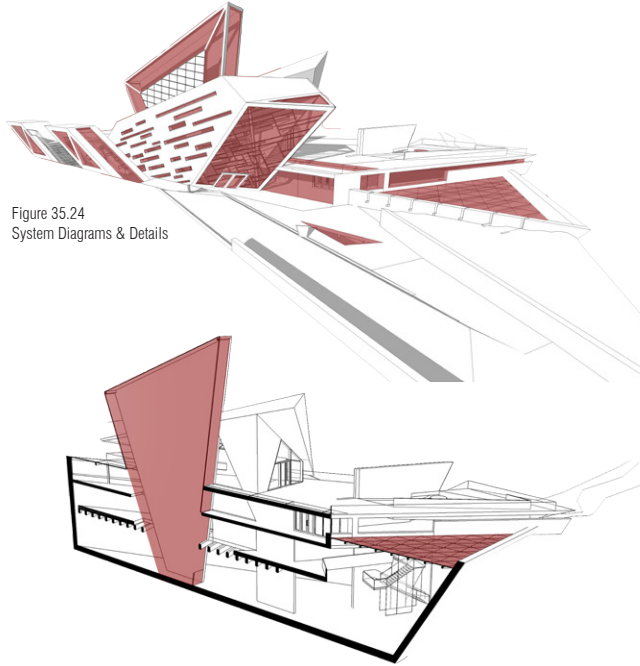


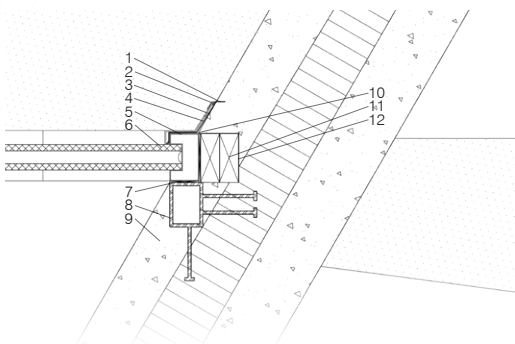
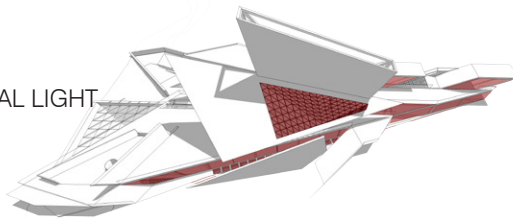
Figure 35,24
System Diagrams & Details

The building takes advantage of natural light for solar gain as well as a majority of the buildings lighting requirements. The atrium on the easternmost half is covered by a thick curtain wall of glass. In the spring when water rushes down the mountains, many years the building will completely flood. This glass holds the remnant of that water through the summer. The roof of the building is also slightly sloped to dump rainwater into the catch basin. Some of water is used for building activities such as flushing toilets and cleaning, the rest hovers overhead of the dwellers in the lower atrium space.

THERMAL CHIMNEY + AQUATIC THERMAL MASS

The wave well detail below is designed to leak ever so slowly-leaving weeps in the caulking once every 10 feet. The weather barrier around the wood bucking is reversed, serving the opposite of it's normal function- to breathe in rather than out- allowing water through to run down the concrete as well as serving as a better trap for the heated air just below the surface of the glass. The design serves as a permanent reminder to the dwellers below of the earth's balance with man's intrusions, as well as an ever-present reminder of their own mortality below potentially thousands of gallons of water.

NATURAL LIGHT



- WAVE WELL WINDOW DETAIL NTS
- 1 CUT-IN REGLET
 - 2 CONTINUOUS CAULKING
 - 3 PRE-FINISHED ALUMINUM CAP
 - 4 60 MIL EPDM RUBBER MEMBRANE
 - 5 THERMALLY BROKEN ALUMINUM WINDOW ASSEMBLY
 - 6 2" TEMPERED GLASS
 - 7 SHIM AS REQUIRED
 - 8 INSET STEEL CONNECTION
 - 9 INSULATED PRECAST PANEL
 - 10 DPNT. TYVEK FLEXWRAP/STRAIGHTFLASH AROUND MULLION
 - 11 2X BUCKING
 - 12 TYVEK WRAPS AROUND WOOD BUCKING

Here are a few structural diagrams showing how the building's bearing walls bite into the concrete slabs. At this connection can also be seen in the model.

As shown, the structure is laid out to be very simple bearing walls, 1 way slabs, and steel columns and beams where necessary. Some beams penetrate through the entire building resting on piers within the earth.

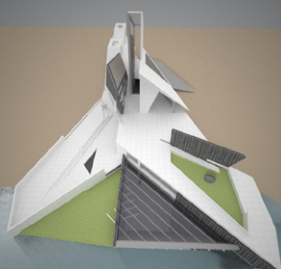
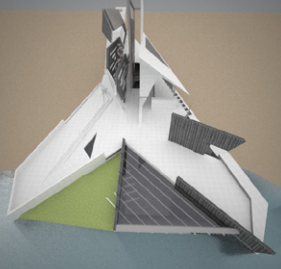
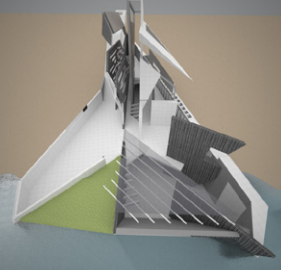
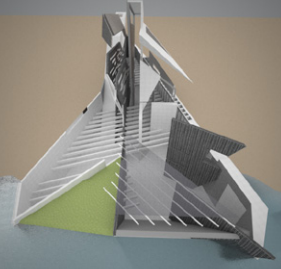
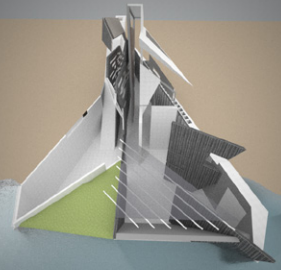


Figure 35.25
Structure Diagrams & Details

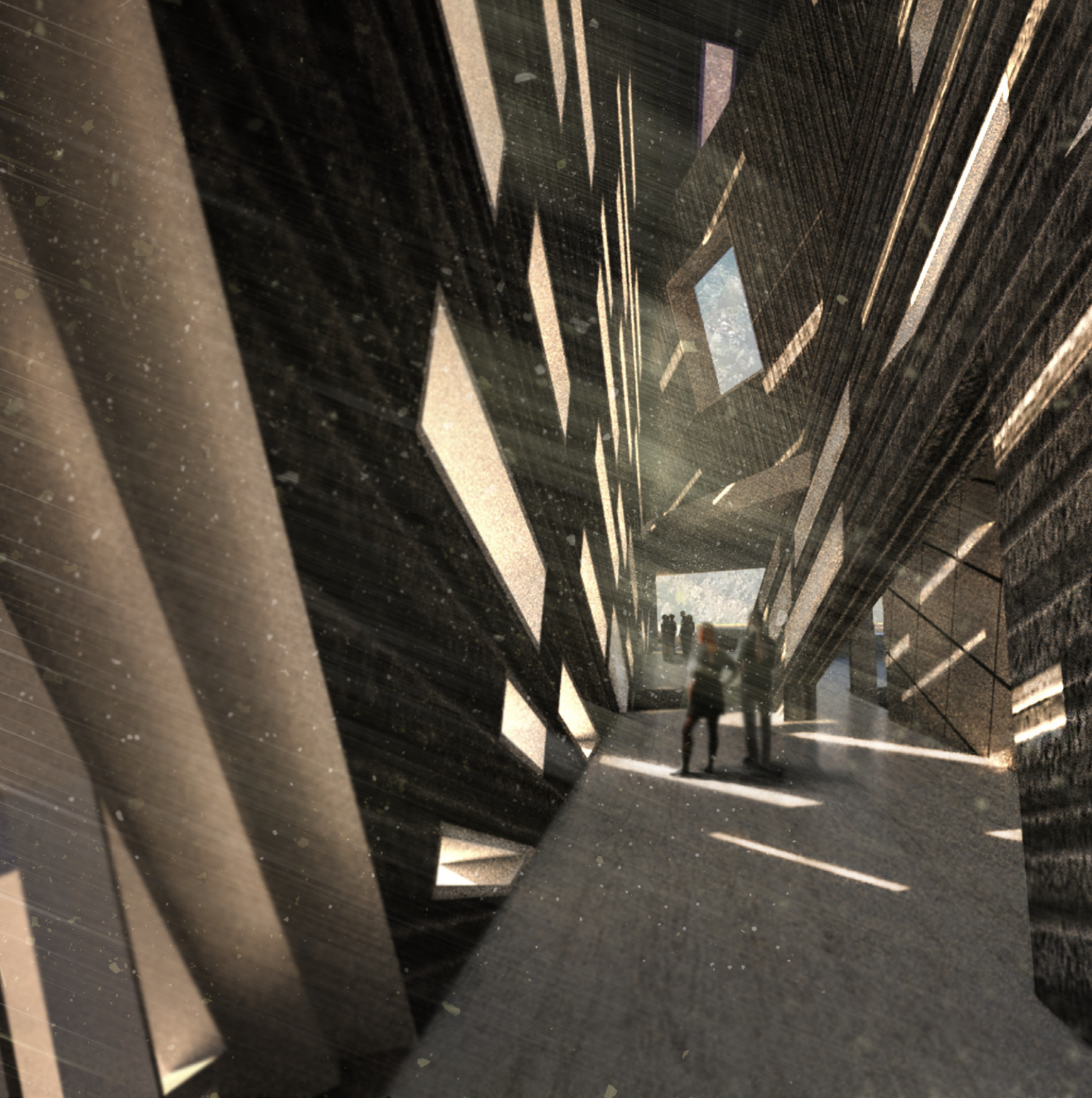
APPROACHING



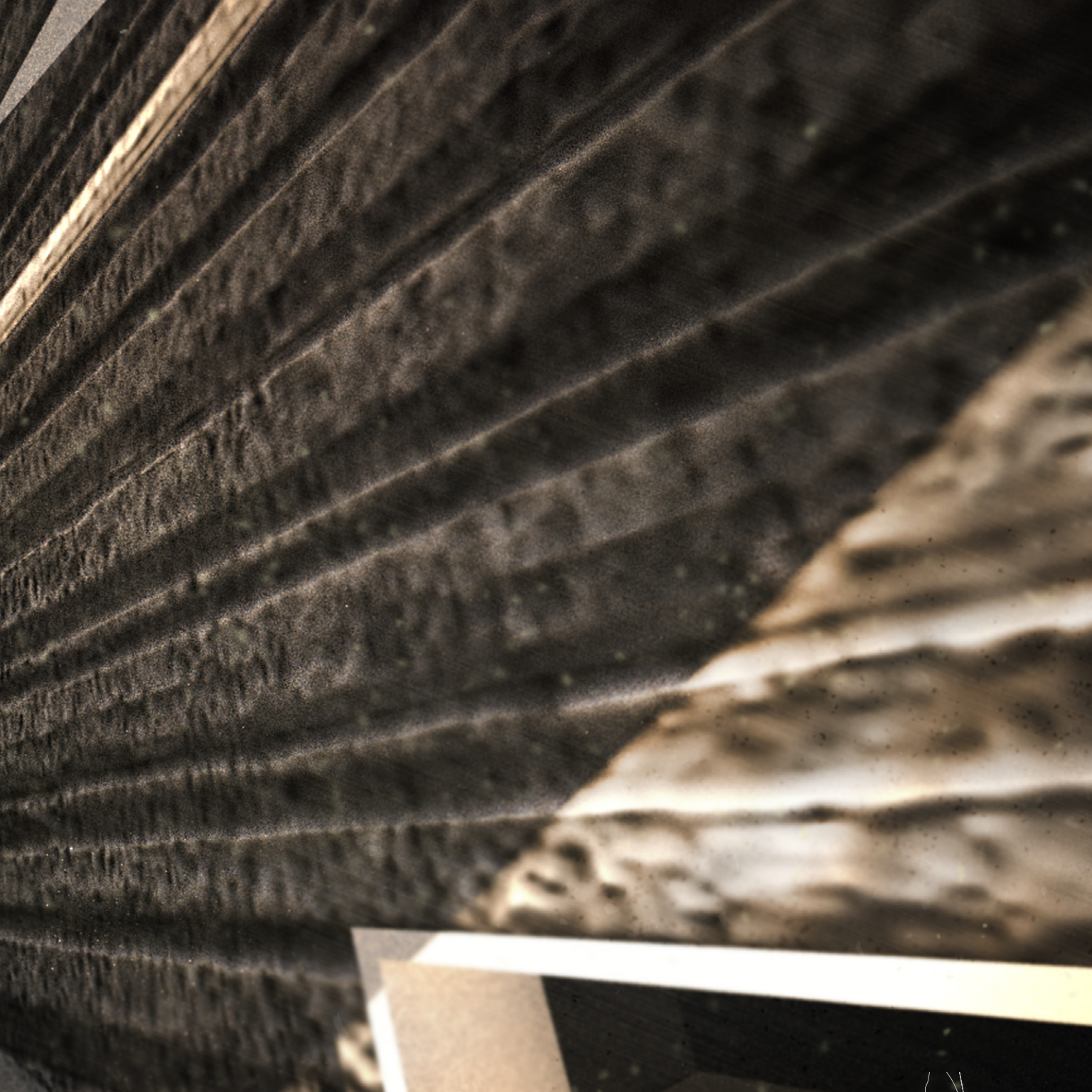
Figure 36.11 Approaching.

The approach is a stepped introduction, slowly descending and holding the dwellers close to the water while simultaneously concealing the view of the mountains surrounding.

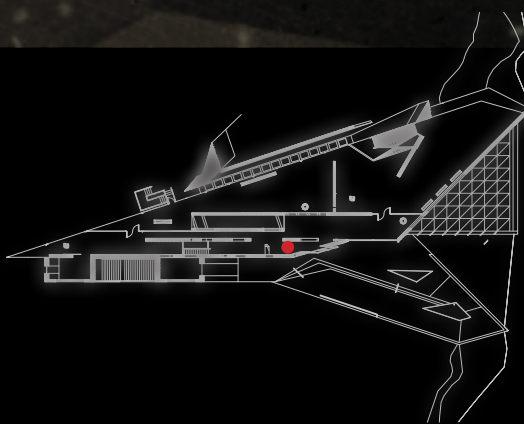


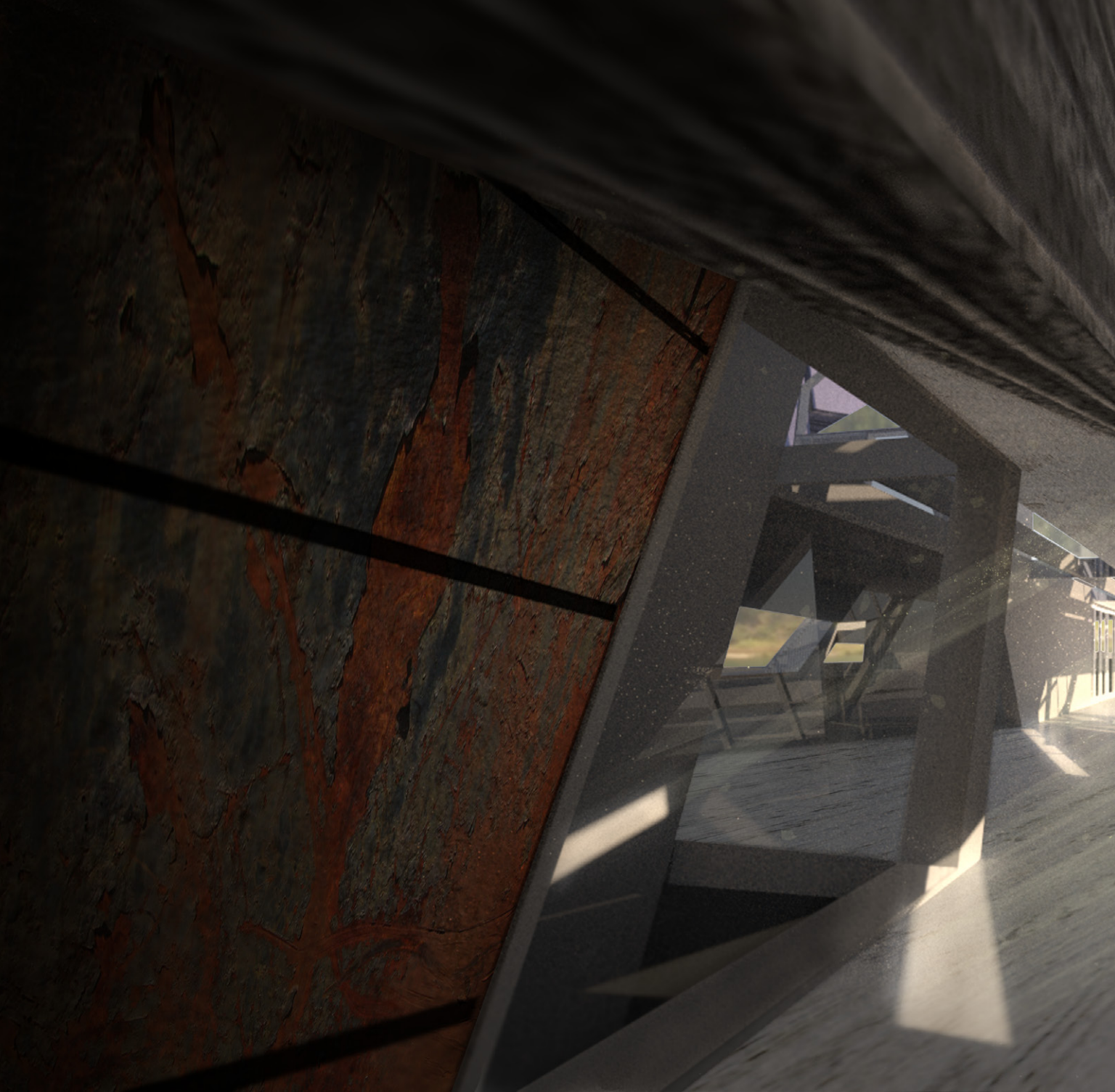


ENTERING

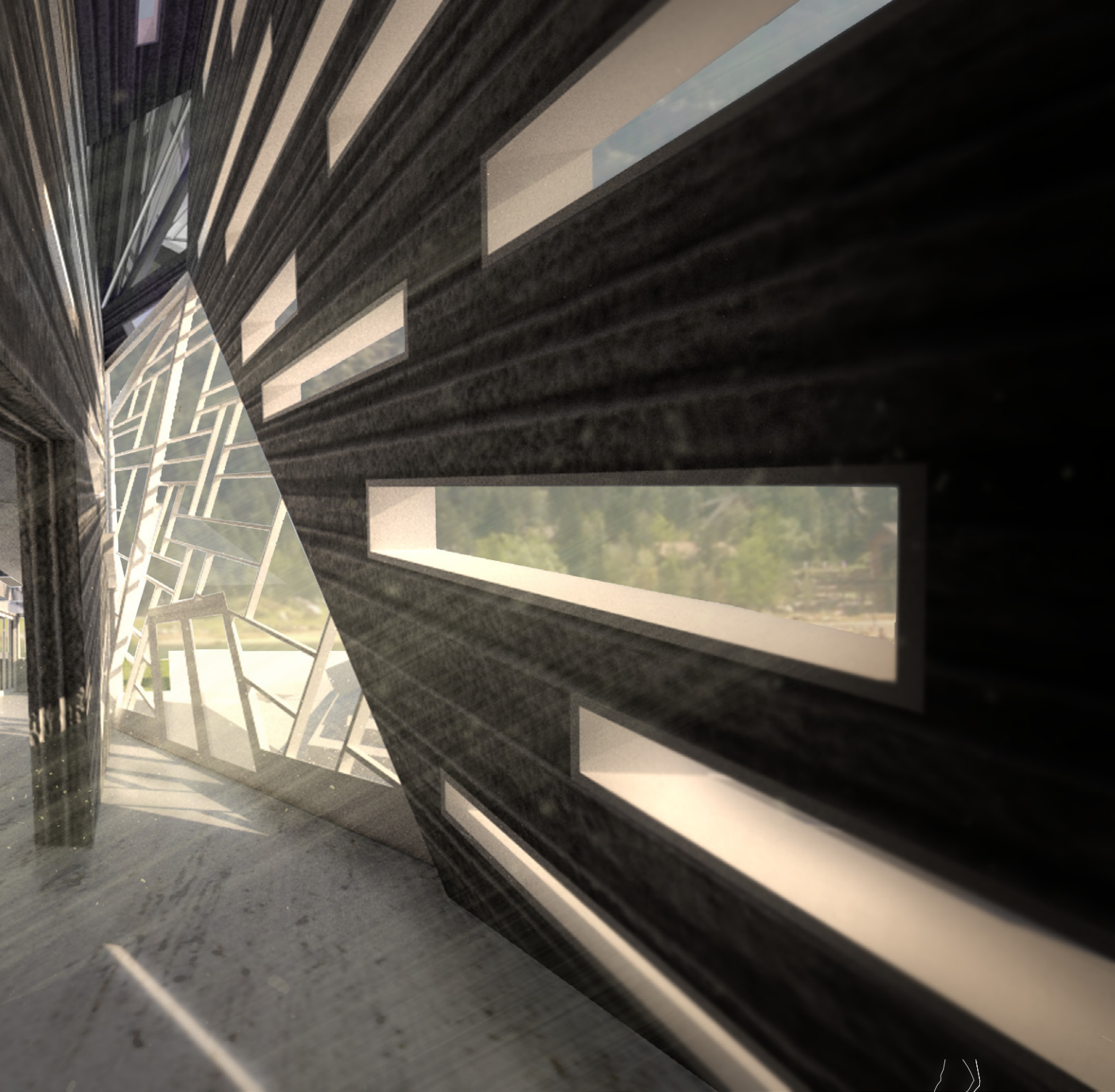


Upon entering, the building becomes a shattered telescope, extending ones perception and Framing the constellations of stone on the mountain beyond

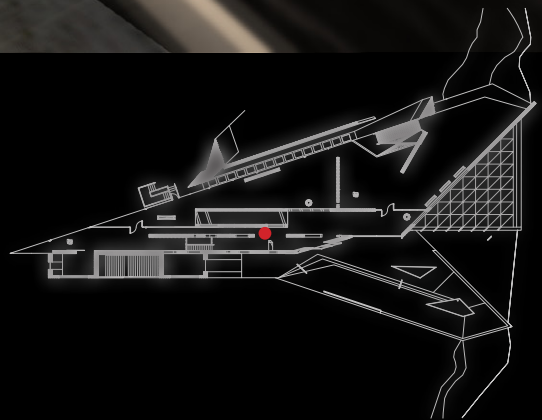


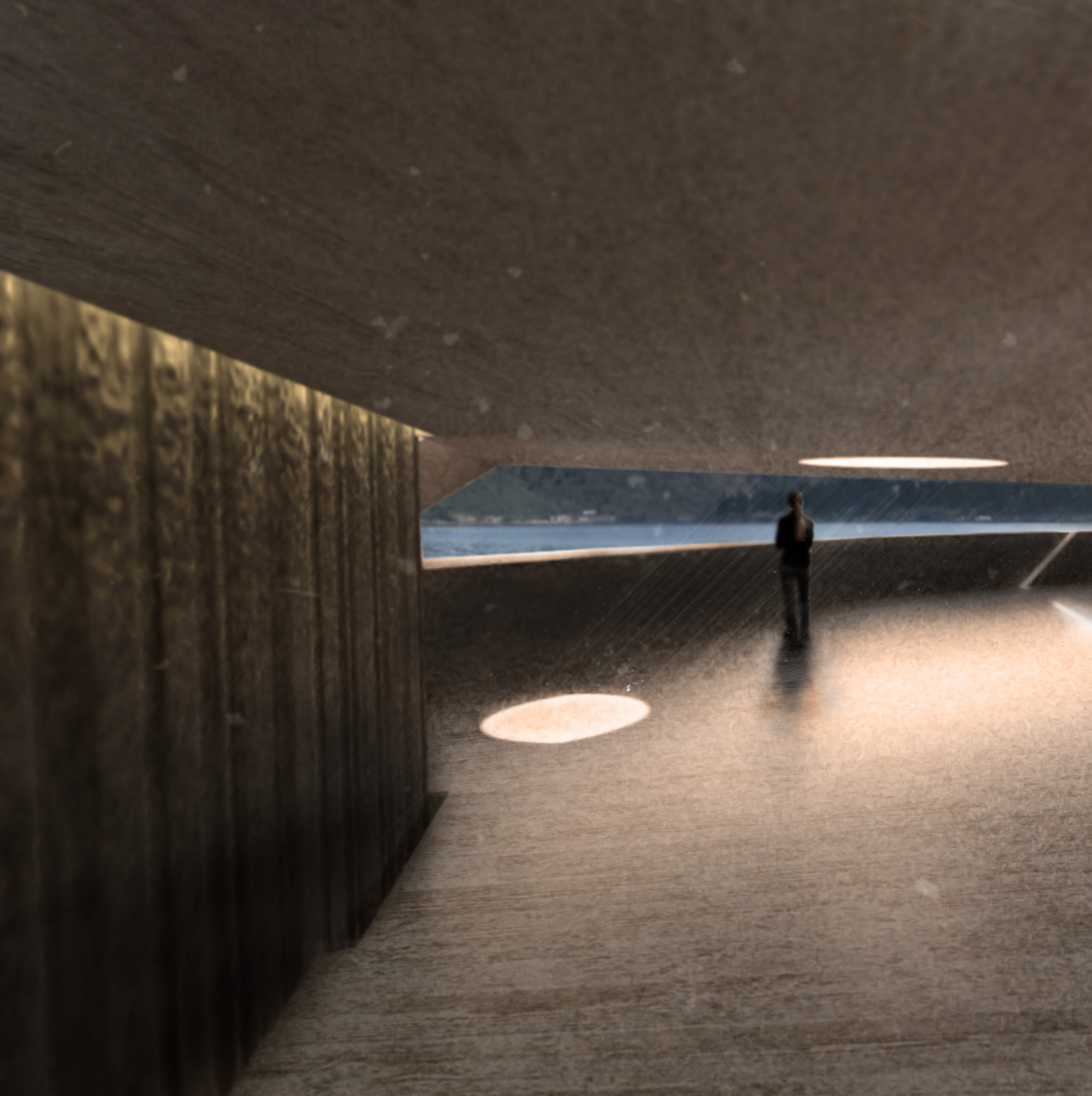


WEAVING



Weaving back, the building frames the range beyond through the metamorphic openings in the walls, and the angular juxtaposition of the entry curtain.



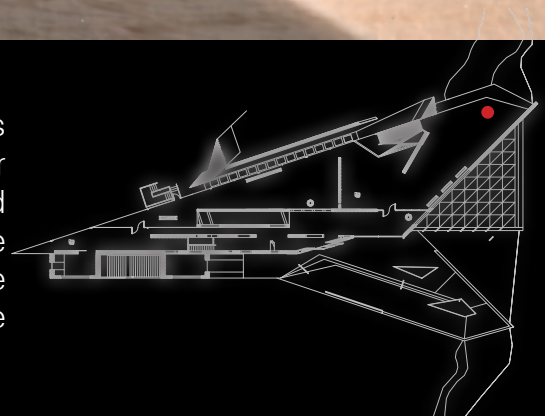


OUTLOOK

Stepping through the ground floor, the dwellers encounter the first lens of this shattered telescope. The lake lens compresses one's vision over the gem-like shimmering of the Georgetown reservoir.



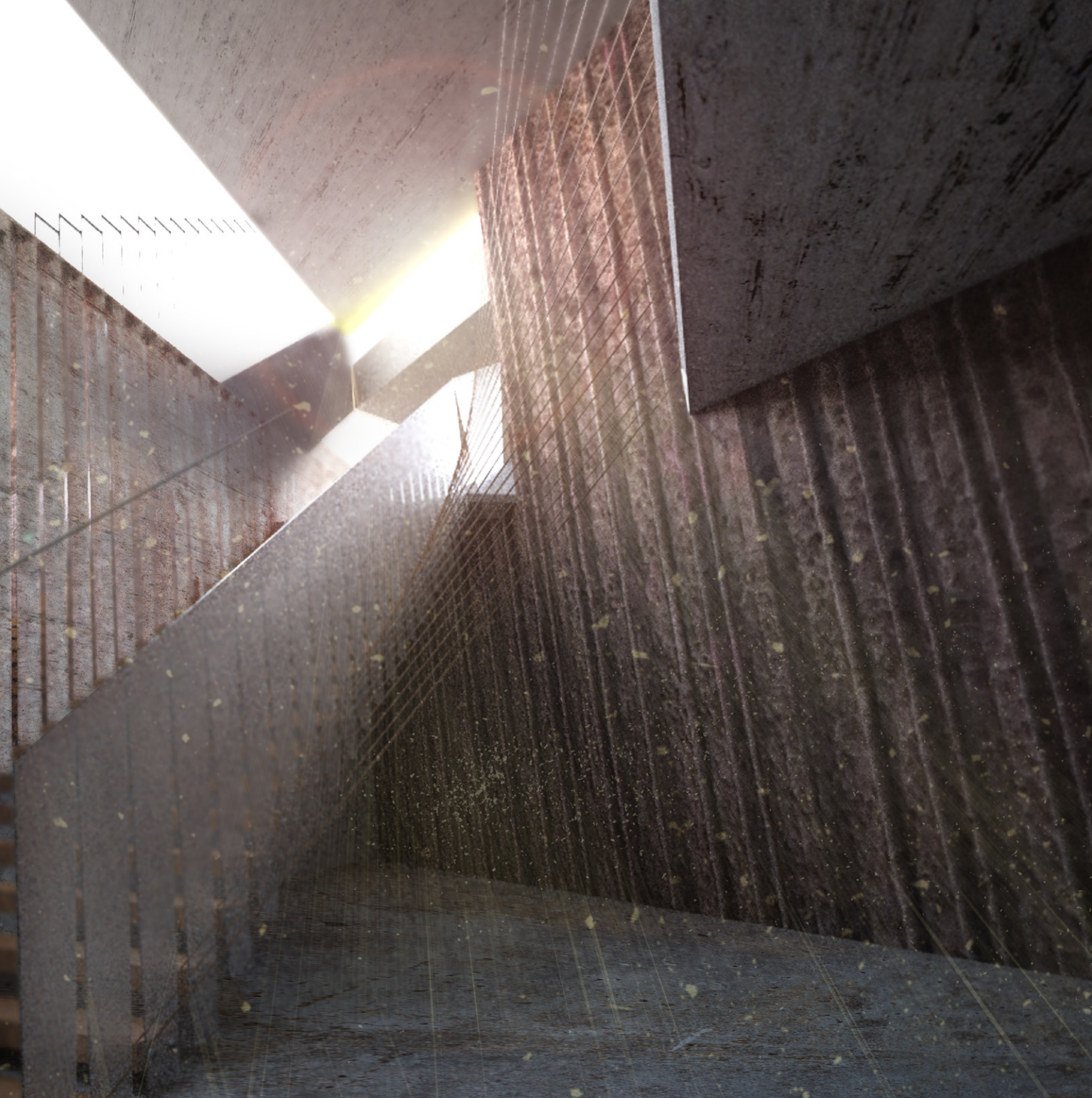
A secondary encounter is made with the oculus above, framing the sky through a singular diaphragm. This space is on the primarily exposed north side of the museum, so users would also be feeling the cool wet air un-sticking from the surface of the lake rushing into the building during the summer months.



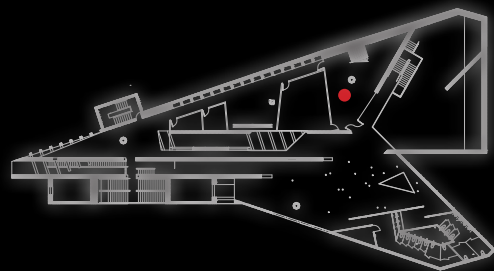


LIGHT FRAME

Like a gem set with the water stained boundaries of the walls, light in the museum is often framed -suspended in a dyad of immateriality, and of being a material graspable object.



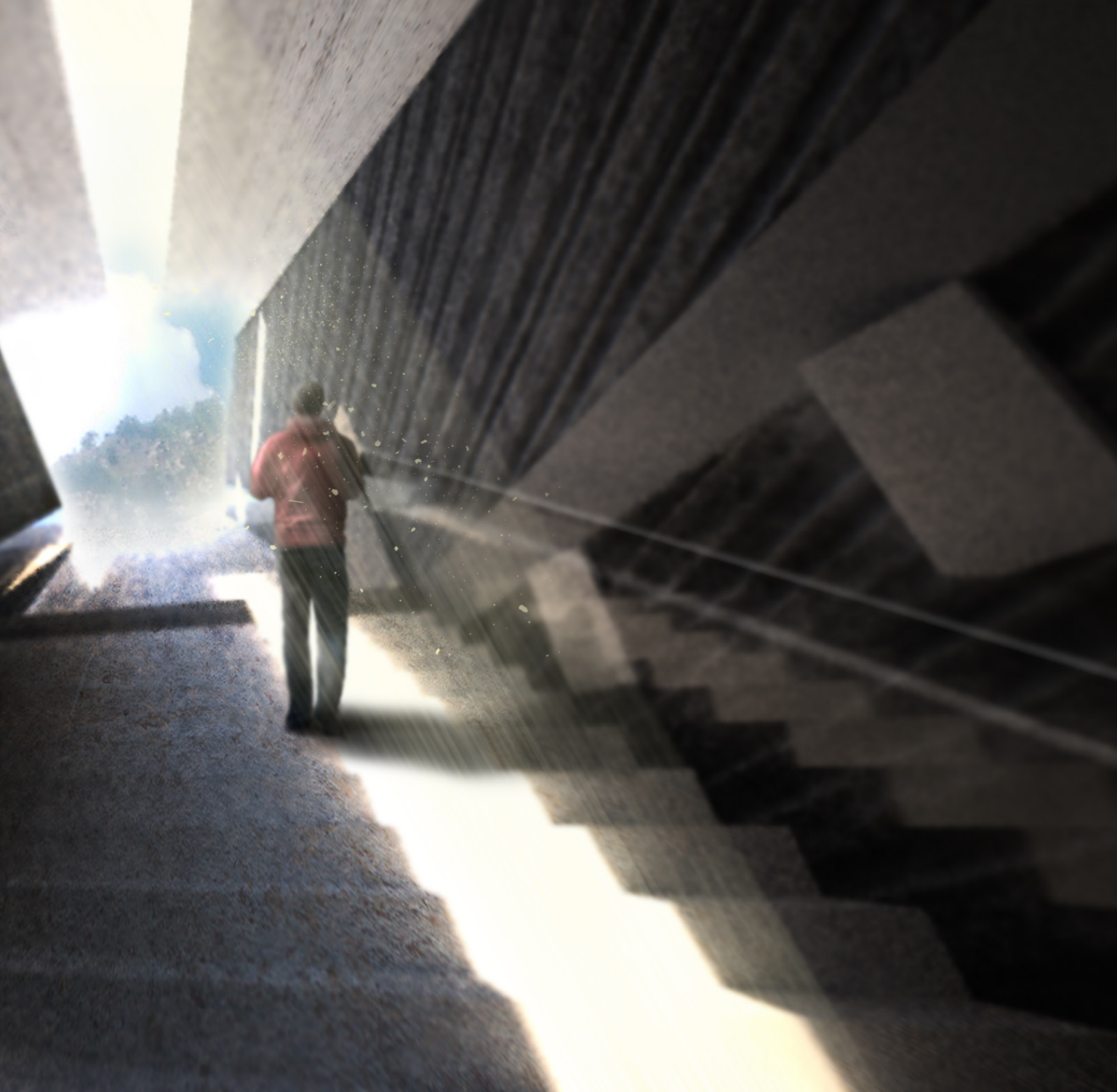
By framing natural light as object, the building, like St. Denis, and Paccioli's Icosahexahedron, becomes a bridge; a mediation between material, the individual, and the cosmos.



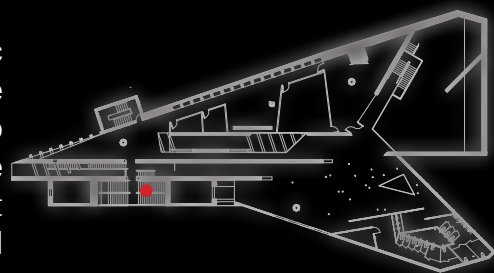


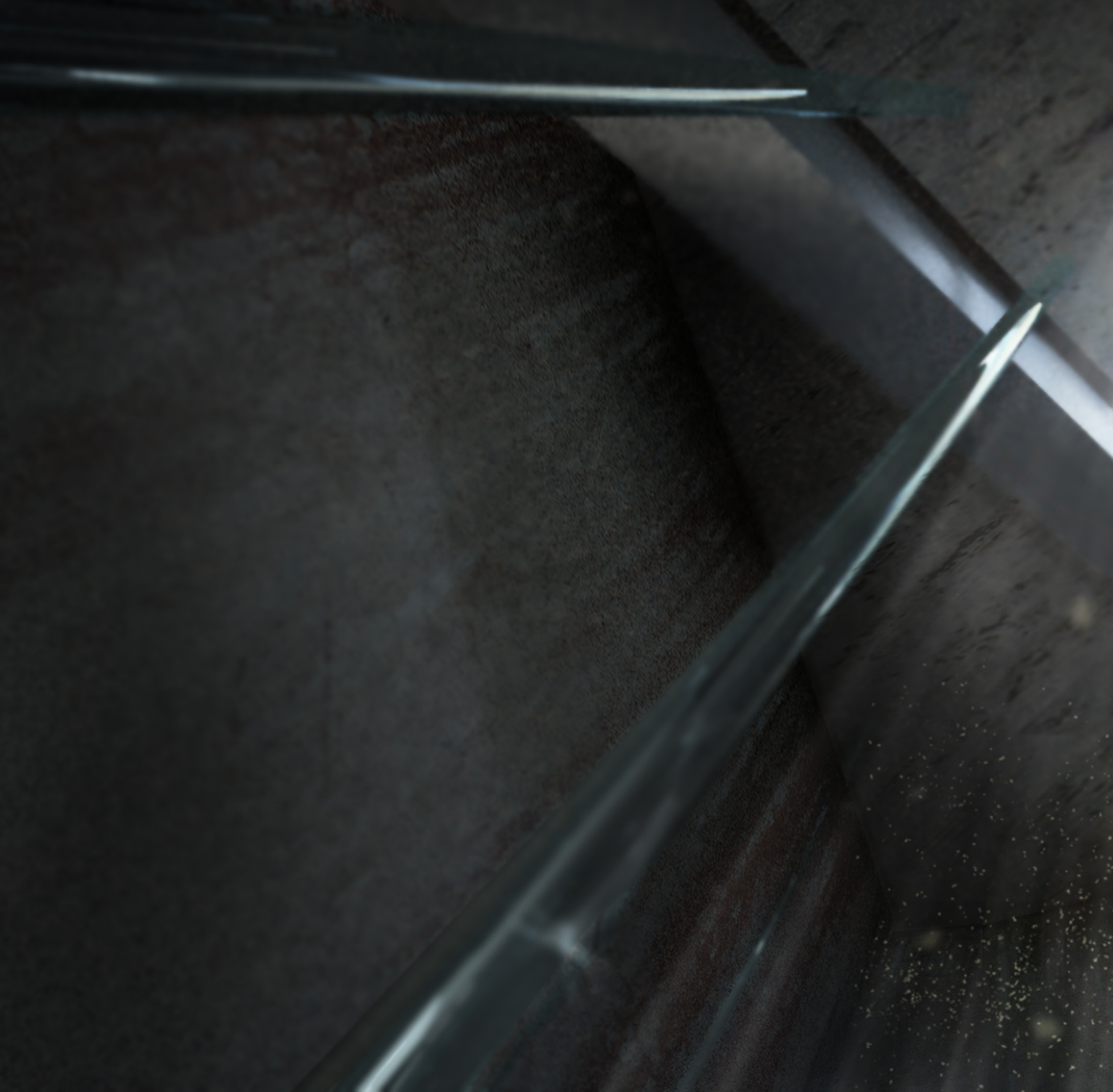
ASCENT

This stair space, compressed between the funicular elevators on the west side of the museum, becomes a shaft mediating the roof, ground, and base of the museum. The inclination of the concrete, and the stacked gradient of the earth creates a call back to the metamorphic formation of silver plume mountain beyond.



Compressed within the slanting tunnel, a telescopic connection is formed between the body and the powerful mountain. Through the apexual relationship of material as well as the climbing funiculars above and below, I intended that the ascent become a sort of disoriented ambulatory meander; slowing and possibly even stopping wanderers mid step.



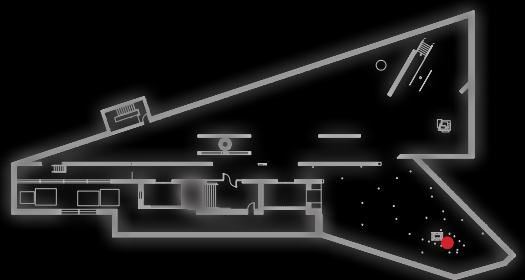


OCULUS

Figure 36.22 Oculus.



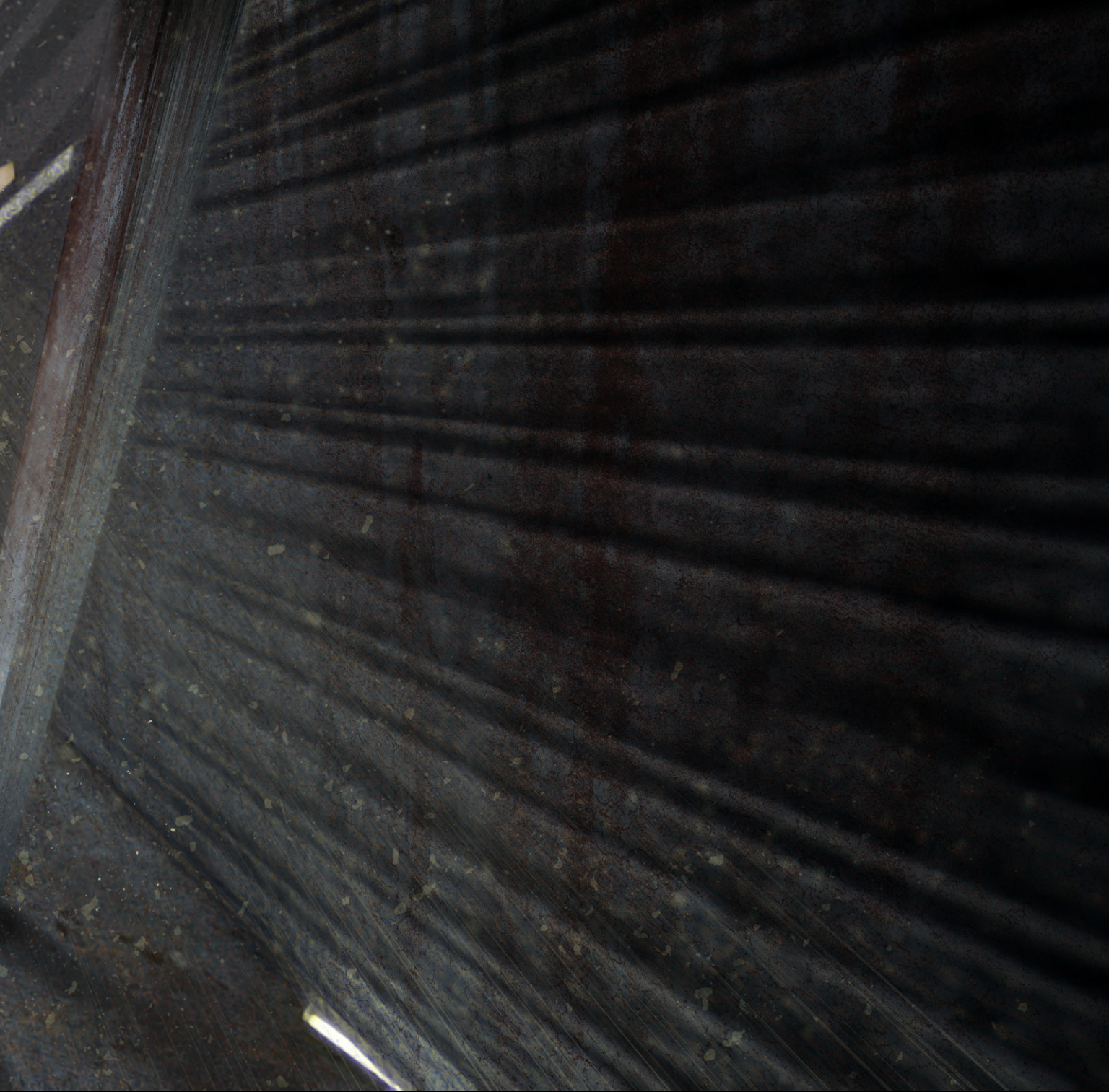
The major chase in the southern half of the building is a light cannon beneath the building entrance. It is in this display space that the geothermal system penetrates through the plate of the floor, allowing dwellers to feel the warmth or coolness radiating from the shafts surrounding.





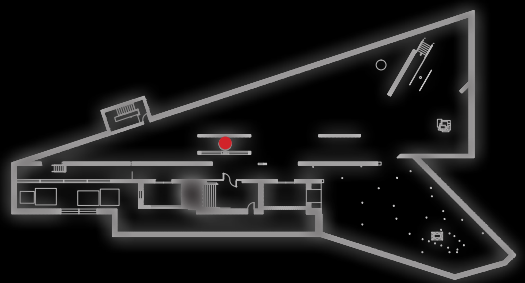
WEDGE BASE

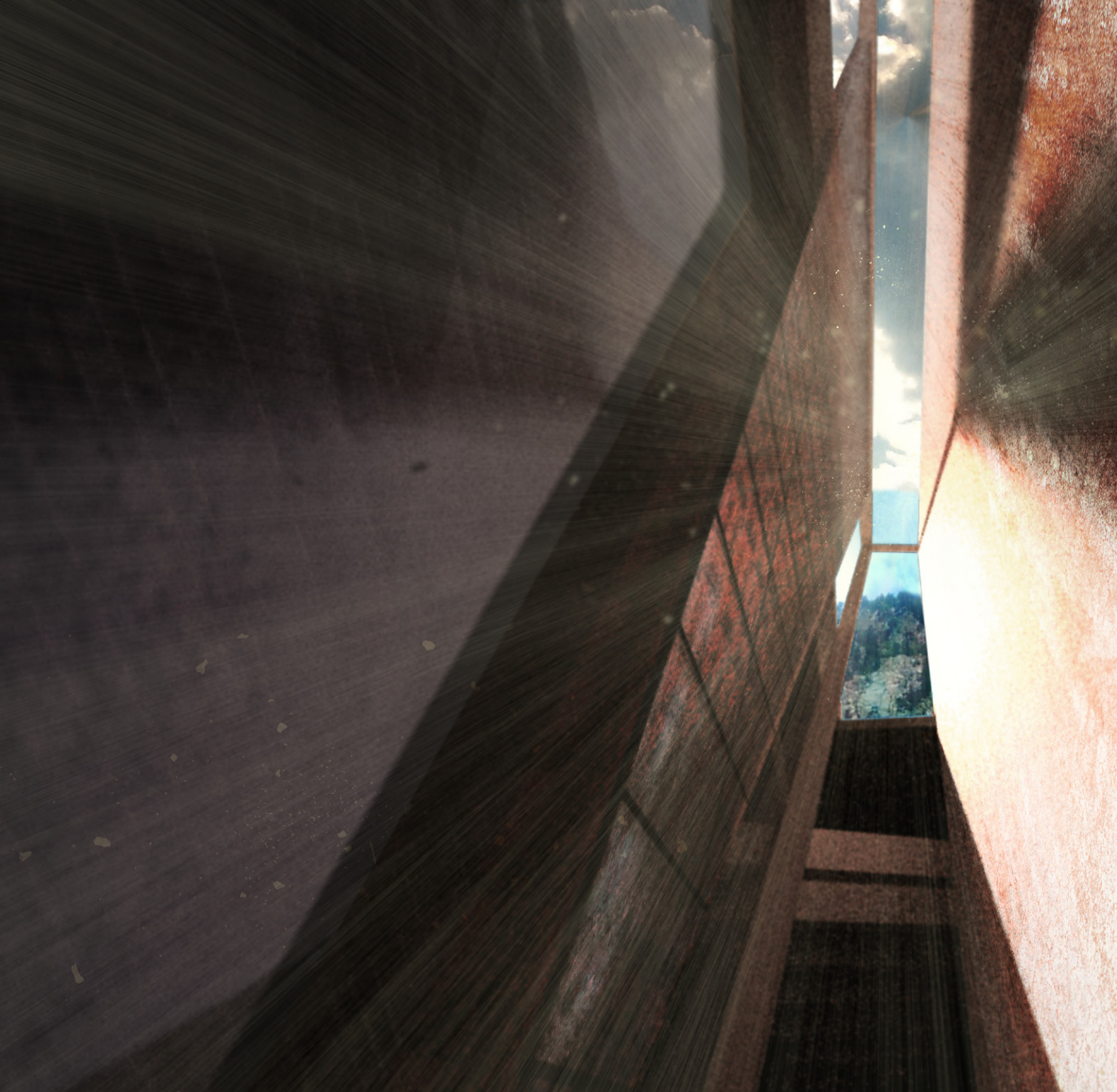
Encapsulated within the central thermal wedge lies the crown jewel of the museum. The searchlight – a call to culture of local Coloradans.



The state mineral. Found at the site. The rarest specimen ever found.

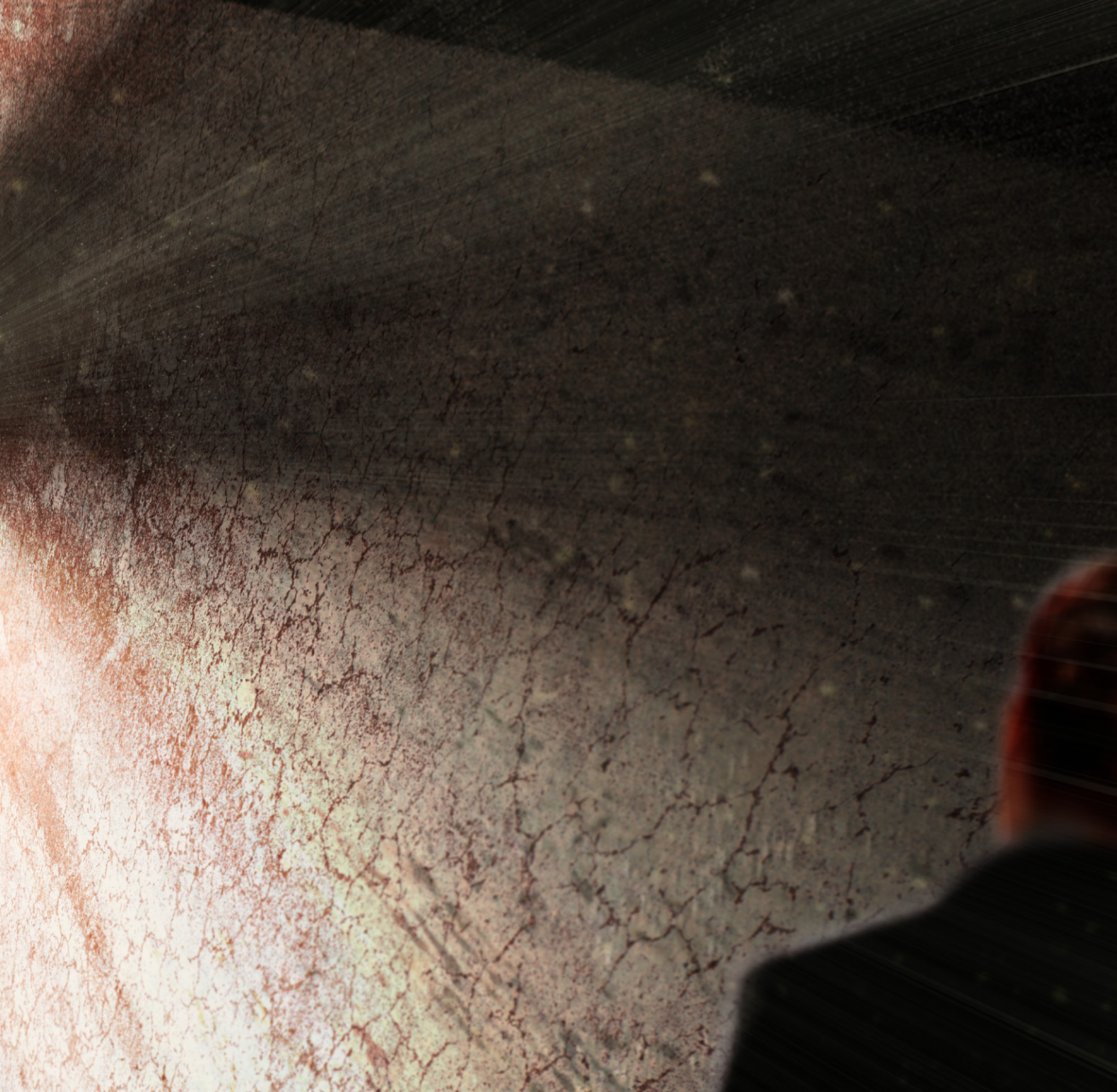
The presence of the rare mineral, one could hope, will enforce the strong link between the void of space on the bottom floor, and the reality of the vacant pits within the mountains left behind by unsustainable mining.



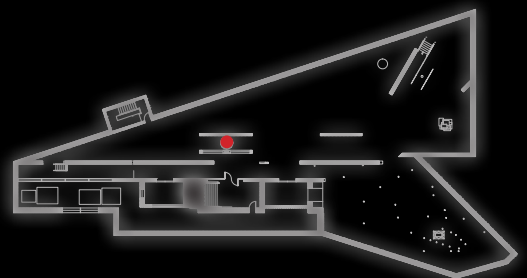


SKY LENS

Looking skyward from the base of the wedge, one encounters another lens of the telescope. The patina left behind by the annual flooding site, a call back to the mineralization within the water, speaks to the nature of dwelling within the fourfold - Opposite the concrete are raw metal panels speaking to this same nature. This space, straddling the threshold of the high-tech and ancient sustainable practices resides in a duality of being both old yet new.



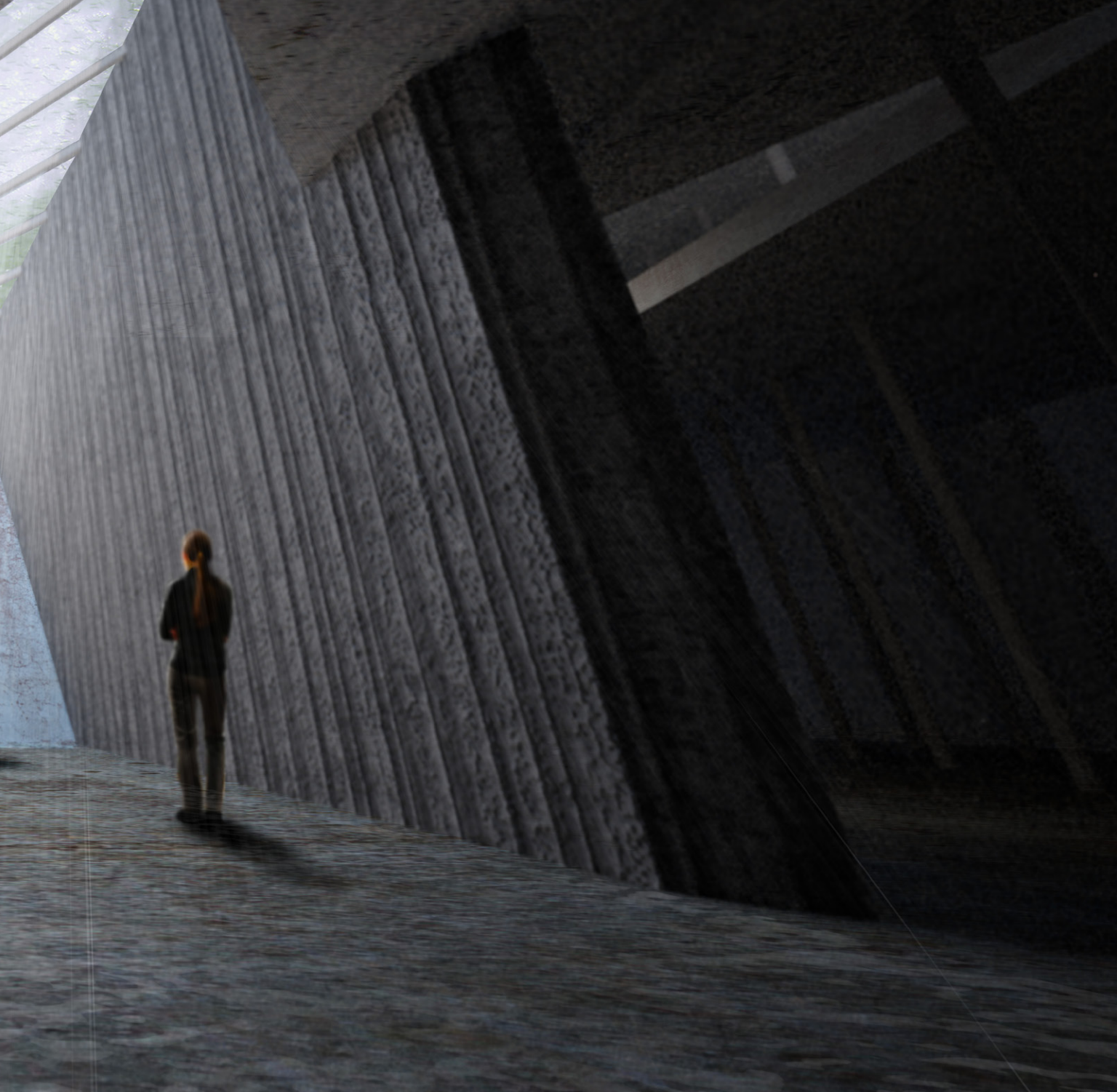
Being an ancient thermal chimney by nature, the element's glass top mechanically unfolds- allowing rain to fall into the space when natural convection is needed, and closing during need of high solar gain. The wedge perceptually extends the distance between one's body and the infinite cosmos above – while framing the tip of Silver Plume Mountain presents the relative distance of the earth surrounding.



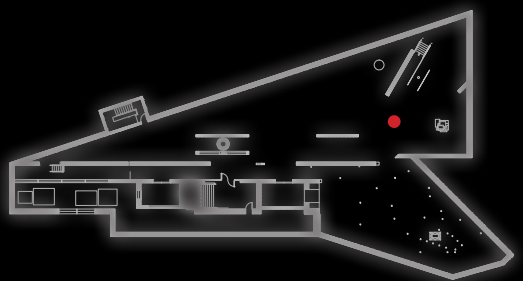


WAVE WELL

An alchemical filter, the wave well presents the Georgetown Reservoir in a new way.



If you remember from earlier, this is the space that is designed to slowly leak when the reservoir floods over the site in the spring – a constant reminder of the weight of the water above, and the mortality of the dwellers below. The Pallasite meteorite framed below the well a reminder of the unpredictable reality...



...Of dwelling on a pale blue dot. Suspended by a thread, in the infinite cosmos.
By no means does architecture have the power to cure the disease of wasteful culture in one fell swoop. By some simmering light, though, it does have the opportunity to make a perceptible difference on the acting practical consciousness of human beings.

And as Gadamer said, only through this means can we gain true experience.



Program Appendix

Summary: On the Relevance of Phenomenology

Matt Qual

Dalibor Vesely

Vesley opens the discussion with talking about phenomenology in architecture and how it is a “tendency to see things in the way people used to see them”. Phenomenology is an attempt to see something for its sensual value and is trying to stay away from criticizing something for what we see as its face value. It asks questions such as ‘how is the experience relevant to what is deemed reality?’ It’s relevance in architecture is quite apparent in that one could argue that people don’t perceive architecture in a Cartesian method from which it was likely designed, but it is perceived in a much broader and sensual experience. Vesely brings up a point, though, which was sparked by Max Schaefer. That point is that phenomenology would not be a ‘thing’ if it weren’t for the fact that modern thought has shifted by supplementing science in the place of perception to define reality. Where phenomenology is a natural response to individualism and culture, science is a response to a recognized and calculated problem. Vesely argues that phenomenology is a tendency to cleanse the modern mind from science based delusions; a return to perceptual experience.

Vesely interestingly brings up the point that we live in a society that has many creative and clever scientists whom architects must measure themselves against. He further states that architects must measure themselves against these types of people not because he thinks that science dominates culture, but that the dialogue brings the topic to a proper level of ‘imaginative vision’. Science leaves behind data and a reference frame that architecture cannot. Architecture occurs in the present experience of its existence. Science occurs when things are reduced to a measurable understanding.

The ‘building’ is analyzed in terms of its existence and its setting. One without the other would not be a complete existence beyond an object. Vesely describes a building being the fabric of the experience, and explains that the role of the context plays an even more important role than any other physical form or geometry. The problem with many modern architects is that the setting is often deemed less important than the form or geometrical relationships of the building itself. The building becomes an object to admire which only relates to itself and is reduced to a matter of aesthetic detailing and personal taste. There are no true meaningful artifacts that are merely self-referential - Those objects which can be reduced a pleasant image which holds similar meaning.

The development of the perspective can be seen as the turning point of thinking. People were never before able to represent reality in a way which was omni-sensual and able to be relatable at face value. Before people could only use art and what they thought was crude representation to describe settings and feelings. With the development of the perspective also came the development of scientific thinking. An experience could be reduced to a series of lines points and colors. The perspectival drawing itself is an idea of pure self reference. This spawned the idea of “significant form” and the romantic period; which the line between the extremes was nonexistent. The appropriate was lost in what was seen as only good or bad. Instead of relating to context and using appropriate cultural reference, each building was viewed as its own sculpture.

“Science and technology are ultimately privileged constructions which have not been brought into an adequate confrontation with a cultural reality broader than themselves.”-Dalibor Vesely

Vesely closes with the reference to Heidegger's examples of how science and poesis could be compared with strip mining and a plow turning the soil. The difference between breaking an object apart and studying its contents, and turning something in ones hands and letting the object reveal itself to you.

Summary: The Eyes of the Skin

Juhani Pallasmaa

The body is informed and shaped by the context of the environment. The lived experience permits different mentalities and attitudes which are directly endowed by natural and man-made atmospheres. Juhani Pallasmaa speaks about the embodiment of architecture in our senses, and breaks down each sensual experience into different components. Juhani implies the importance of cultural environment by describing the loss of such culture as only being a mechanical response to a stimulus. If there were no greater culturally contextual response, what meaning would there be in any response at all?

He goes to argue that many dwellings today not only are missing the core interaction between themselves, humans, and their environment, but completely lack the potential to do so. This is the tragedy of modern society. With newer and more technically efficient materials comes a rise in faux architecture. Architecture is often times reduced to the cheapest and most efficient materials, along with pleasant detailing. Pallasmaa explains that architecture is a human extension of nature which should be relatable to us who inhabit it. Most times, though, the connection between what is meaningful and what is efficient is lost in translation or never existed in the first place. When this happens, the architecture never directs us to anything greater than itself.

Often, when people want to isolate their senses such as sound or smell, they close their eyes to shut out the overwhelming stimuli. Through the eyes we are allowed to perceive our surroundings perhaps greater than any other sense; So much, that architecture has been solely focused on pleasing this sense. Pallasmaa expresses this problem in realizing the importance of architecture being not a series of isolated images, but the overall bodily experience.

Pallasmaa talks about the topic of shadow and it's often forgotten existence. Modern thought has associated a sort of safety to being totally drown in homogenous white light. Pallasmaa views this as a torturous experience; a paralysis of the imagination which is synonymous with that of homogenous repetitious space. Homogeny weakens experience and promotes a loss of sense of place. He says that 'the shadow gives shape and life to the object in light' and therefore shadow should never be forgotten. Successful architecture will always have a sort of peaceful breathing of shadow and light.

A tragedy of modern day cities is their width, and the loss of the echo. No longer is there a peaceful silence in which the echo can permeate. Contrarily, belief in the present is that a space must be filled with a null void of preprogrammed music and background filler in order to be safe and comfortable. Rarely are we allowed to use our sense of hearing to sculpt the void in which we stand. Tranquility, solitude, and the beauty of silence seem to be things of the past. Today's culture believes that productivity is associated with playing the top 40 songs from 1960 – 1980. There is no longer such thing as the ringing of your ears in a silent tranquil space, no longer such a thing as a museum of waiting and patient silence. Rarely can one feel and hear the rising and falling of their chest cavity when taking a silent breath, or the private dialogue in one's mind when experience a work of art.

Pallasmaa speaks of the importance of scent in architecture, and its unique power to provoke a vivid daydream. He goes on speaking about touch and the romantic instance when a hand touches the door handle when entering a building, and its welcoming hospitality, describing it as an architectural handshake. Smells, touch, colors, and other sensations, he states, all provoke an oral response. Caressing a marble surface with your fingertips or seeing a lemon split in two hint at an oral response.

Architecture is experienced through lived perception, thus transcending geometrical form. Mimesis of the body, or putting oneself into the designed space, is important when considering how the space will be perceived. He says that “we encounter ourselves in our work” through metaphor and lived experiences of structures embodied within an artifact. He argues that the human unconscious holds instinctual reactions which can be unlocked through architecture to reveal beauty and deeper meaning on a universal scale.

I believe that the topics discussed in *On the Relevance of Phenomenology and The Eyes of the Skin* are truly important when designing and speaking of true Architecture. Too often today is architecture reduced to the minimum program, and holds no deeper meaning to the greater cultural dialogue. Scientific thought has led to the idea of Realism, being that an object holds no deeper meaning than what can be related to the person through its physical embodiment. It is truly tragic that the poetics of thought and relation to culture and artifact are so lost in the bustle of modern day existence. Though there are parts of me that wonder if it was truly science that killed poetry, or if the poetic view of the world ever existed at all beyond people who were advocating for its existence. Oftentimes people who are living in their own self-centered realities would never take the time to make the connection if it wasn't spelled out for them.

Program Appendix Continued

Summary: Building Dwelling Thinking

Matt Qual

Martin Heidegger

Heidegger begins the commentary by posing two questions:

What is it to dwell?

How does building belong to dwelling?

Heidegger believes that a home can be a dwelling, as well as something that is not. A person can be at home when at work, on the road, or in good company, but it is not necessarily dwelling. He speaks of dwelling as it is lived more than felt. Dwelling and building are related, as one is a means and the other is an end. Building was spawned in response for us as humans having the need to dwell. We see though, as a society, as if building and dwelling are two separate things. He believes, though, that language can bridge the gaps between the building and dwelling and somehow relate the two in a meaningful way.

“Man acts as though he were the shaper and master of language, while in fact language remains master of man.”

He goes on to explain that words can be broken down into their roots and through these relations we can find out how building and dwelling are now separate things. In German, Bauen means building, while the high German word for building is Buan, which means to dwell. He goes on to relate the word neighbor[Nachbar] as being synonymous with [Nachgebur] and near-dweller [Nachgebauer]. Bauen which he earlier described as building, can also mean to dwell. Ever reaching deeper he goes on bauen, buan, bhu, beo, and bin which means to be. Ich bin-I am. I am as it is to dwell. To be a human being is to well.

Dwelling is never thought of the basic character of being, more so as being in the state of living; a verbal action which is often thought of as menial tasks such as cooking and cleaning or doing ones laundry. Recently dwelling and living have been thought of as being separate things as much as dwelling and building - due to our ability to make 'home' anywhere we feel comfortable. Through lingual analysis Heidegger believes that we can assume the historic reality that building IS dwelling, that dwelling is living, but not that building typically is living. Through living and through buildings people are allowed to dwell.

Through more language analysis, he concludes that to free or to be free is to spare. Sparing is not freeing someone from certain agony, but rather to leave something beforehand in its own nature. Dwelling is preserving and sparing – to let the essence of things remain and to preserve the importance of an object or being's core integrity.

Heidegger speaks that dwelling is something that only happens on earth, but what of somewhere like the ISS? Are they not dwelling in their own way?

Heidegger breaks down reality into four dimensions beyond the four that we directly perceive. He describes the four dimensions as the ones which bring oneness to our existence.

The Earth- the habitat of dwelling which is encompassed by

The Sky- the dwelling place of the beckoning messenger of the godhand

The Divinities- Through which we have connection to the other four realities

The Mortals- The dying ones.

Through the fourfold humans can dwell. By missing one of dimension of the fourfold, the simple oneness in which existence takes place becomes unapparent. Dwelling is the sparing of the fourfold and preserving the things through which humans build their own existence.

Building is similarly related to the fourfold in that it exists in the same oneness as does dwelling. A site on which something is built reveals itself through the building of things. Heidegger argues that things become symbols through their existence at the time of their building. Similarly spaces only become places through the virtue of the things we build on them - 'space' is not place. The human relation to place is dwelling as much as dwelling is the fourfold.

Summary: Chora, Volume Six: Intervals in the Philosophy of Architecture.

Against Sustainability: Traversing the Fantasy of Sustenance and the Topology of Desire

Donald Kunze

Sustainability must by nature be wholly believed by all such that in order to believe inversely, one's argument would be instantly invalidated. He argues that sustainability should be considered a fantasy. By calling it a fantasy, Kunze means that it is available to conversation on a theoretical basis. Sustainability is a fantasy in that it as a collective construct that is publically accessible, as well as essential when speaking of ones position in any network of symbolic relations. But there are multiple types of fantasies; the positive fantasies-ones which are essentially a stunt for attention to a topic, or the "Dirty Fantasy"- that which is shrouded by the positive fantasy.

Sustainability is often seen as a "logic that works so long as it isn't scrutinized too closely." Most people claim sustainability but don't truly practice it in their lived experience. Sustainability is often seen as an objective application of a set of standards-which is the problem. People often see it as something that the other guy will do, since I don't have the means necessary to make a difference. Instead of acting, many people see what propaganda is displayed as sustainable living and accept that bad things will happen if someone who has the power to apply the formula doesn't do something.

Sustainability is often preached as propaganda (dirty fantasy). The industry uses fear and anxiety of what might happen if you don't conform to get the message across. This is similar to what Kunze refers to "architecture of fear". He speaks of the dirty fantasy of the city as the fear of other people. Technology increases this fear by making us ever more aware of these peoples existence. He says the fact is that due to technology people have become ever less connected with the true culture of the city. People are becoming obsessed with Hollywood culture due to its presence and advertisement in every medium of our existence.

Sustainability has been historically seen as coming to terms with nature, instead of nature coming to terms with humans. Kunze finishes the dialogue with bringing the Garden of Eden, and relating it as being the most sustainable architecture-a gift from god.

Building and dwelling as a derivation of language is an interesting correlation. Somewhere in time building and dwelling became two separate things, but they were once in the same. The same is of sustainability and building. At present times it is not economically cheaper to build sustainably for most owners bottom lines. It takes a certain ethic for most owners to want to build sustainably, but hopefully one day through architecture we will be able to re-link building, dwelling, and sustainability through the fourfold, and through perceptual intersubjectivity. I feel that most architects goals should be to link these things through contextualization of history and under one simple existence such as the fourfold.

References

Cover Page Image: <http://www.treasuremountainmining.com/catalog/images/EB0412METR4.jpg>

Vesely, D. (1988). On the relevance of phenomenology. *Pratt Journal Of Architecture*, 259-62.

Pallasmaa, J. (2005). *The Eyes of the Skin: Architecture and the Senses*. West Sussex, England: John Wiley & Sons Ltd.

Gadamer, H-Georg. (1993) *The Enigma of Health: The Art of Healing in a Scientific Age*. Stanford University Press.

Heidegger, M. *Building Dwelling Thinking*. New York: Harper Colophon, 1971. Print.

Heidegger, M. *The Question Concerning Technology*. Basic Writings Ed. David Farrell Krell (Harper & Row, 1977), 287.

Kunze, D. (2011). (Why No One Can Be) Against Sustainability: Traversing the Fantasy of Sustenance and the Topology of Desire. *Chora: Intervals in the Philosophy of Architecture*. Volume 6. McGill-Queens University Press.

Perez-Gomez, A.(1985) *The Myth Of Daedalus*. *AA Files* 10:49-52 (London, England: Architectural Association).

Perez-Gomez, A.(2006) *Built upon Love: Architectural Longing after Ethics and Aesthetics*. MIT University Press.

Lindberg, D. (1976) *Theories of Vision from Al-Kindi to Kepler*. The University of Chicago Press, LTD.

Crow, J.(2011) *The Sacred Stones of St. Denis* *Chora: Intervals in the philosophy of architecture*. Volume 6. McGill-Queens University Press.

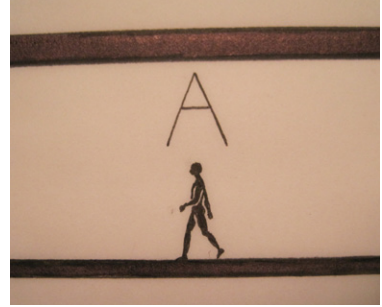
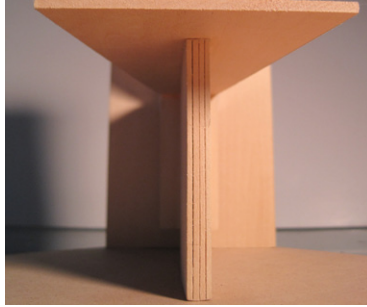
Jessen, K. (1996). *Georgetown: A quick history*. First Edition. J.V. Publications.

Elkins, J. (2000). *What Painting Is*. Taylor & Francis.

Previous Studio Work

SEMESTER 1

YEAR 1
Space
Model

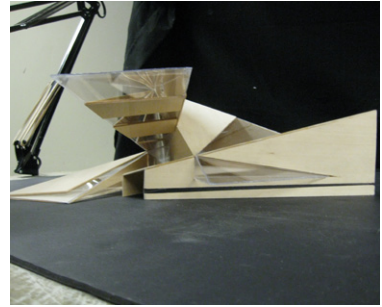
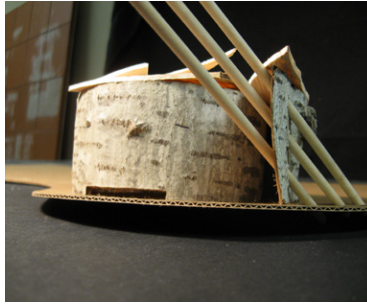
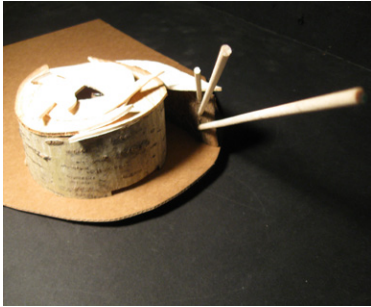


Parti

Master
Copy

YEAR 2

Teahouse

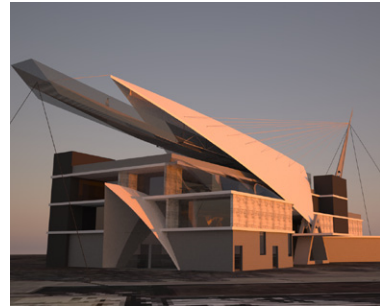
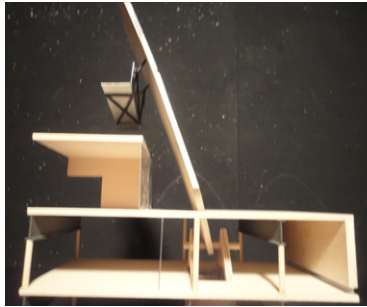


Boathouse

Fugue
Theatre

YEAR 3

Folk Art
Museum

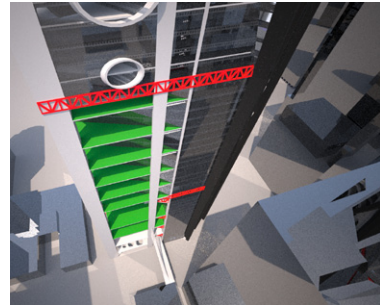
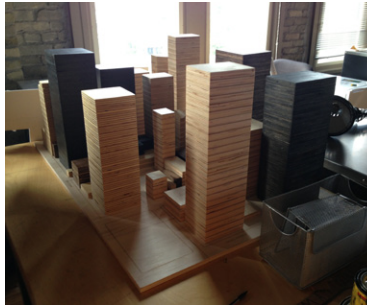
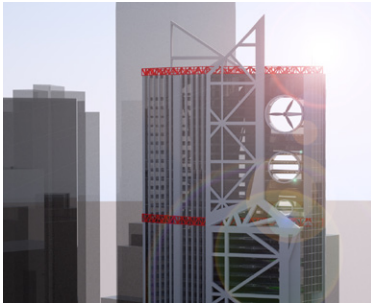


Cube

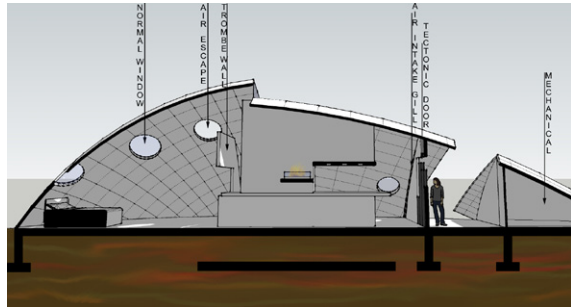
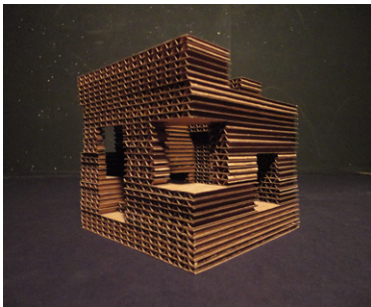
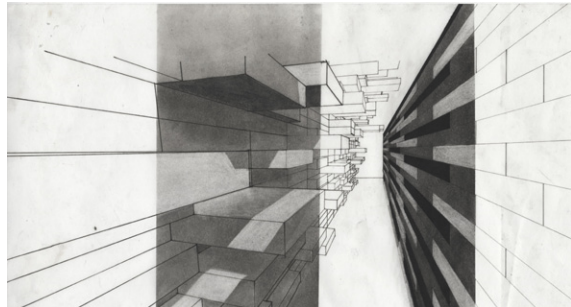
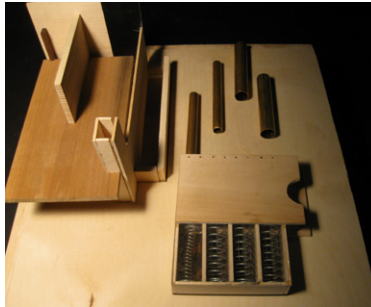
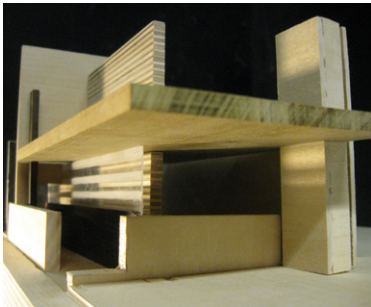
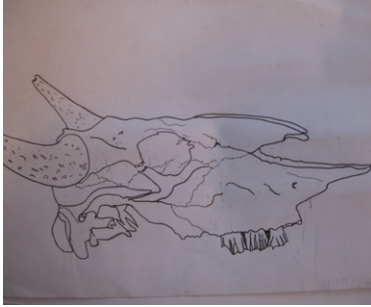
Spaceport
Hotel

YEAR 4
High Rise

Study
Abroad



SEMESTER 2



Bio

Matthew L Qual
NDSU 2015
Leed Green Associate

601 Ash St.
Lisbon, ND
58054

P | 701-680-1827
Matthew.Qual@ndsu.edu

“Go Bison”
-NDSU



