

IN HUMAN

Architectural Thesis by Chris Carter

“as a child you live in an adult world that is out of scale with your body and proportions. And you constantly exercise your imagination around a world of toys that are further out of scale”

- Christopher Boffoli

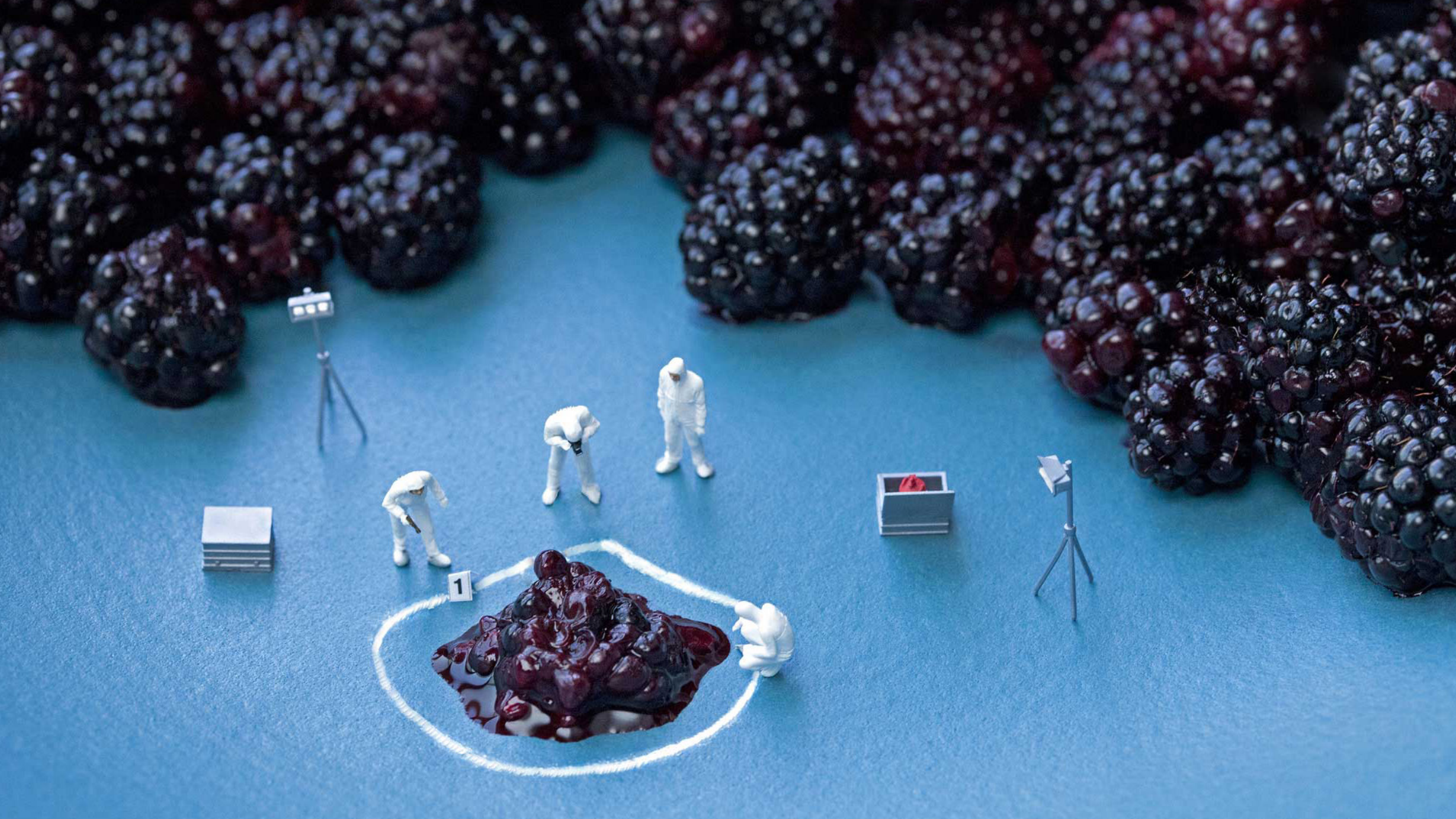





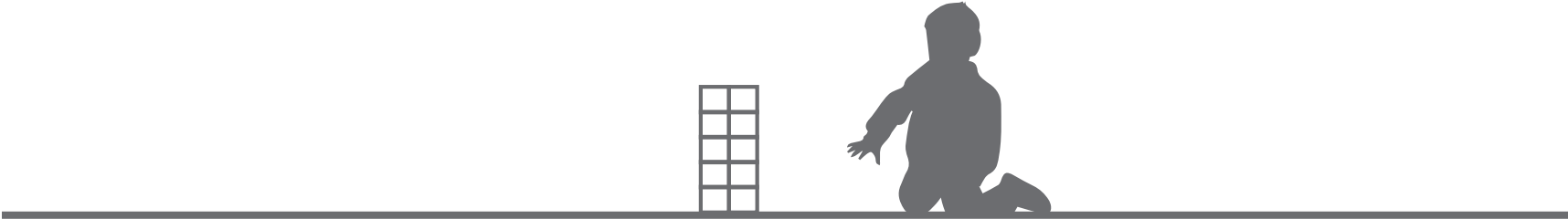

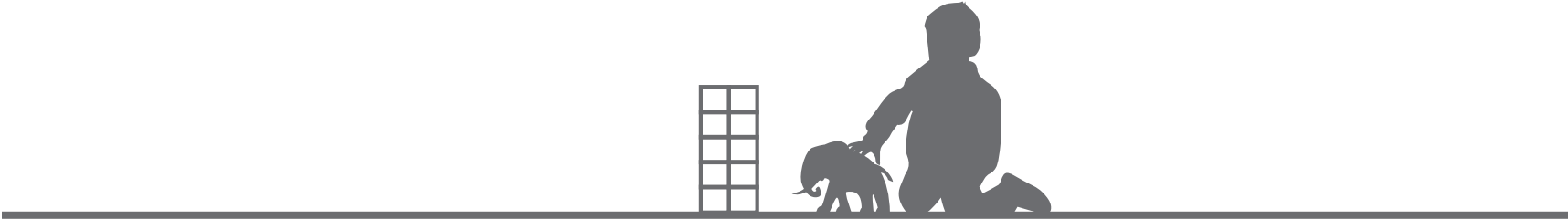

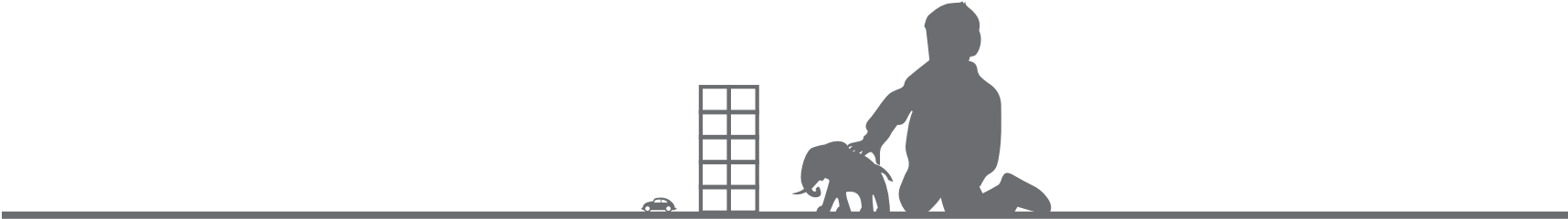

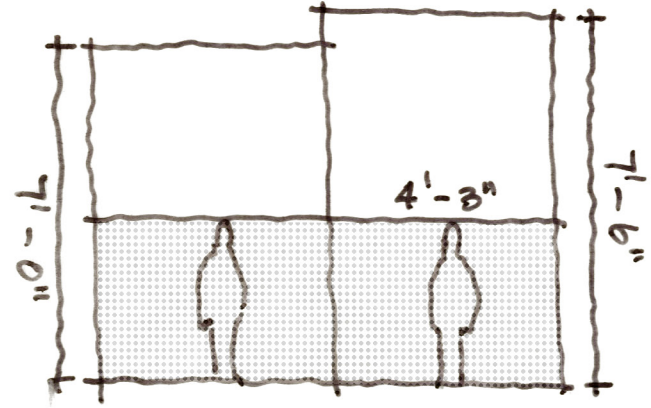
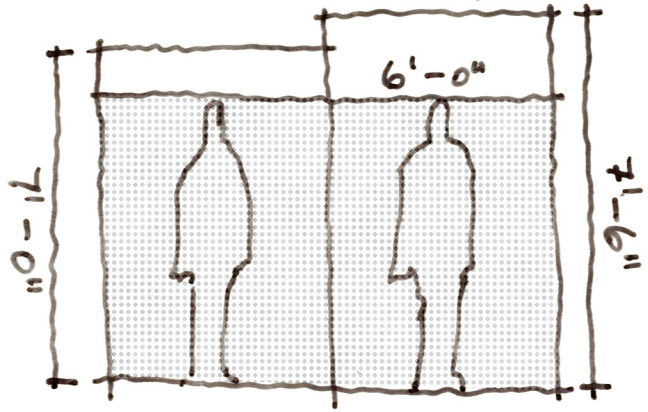

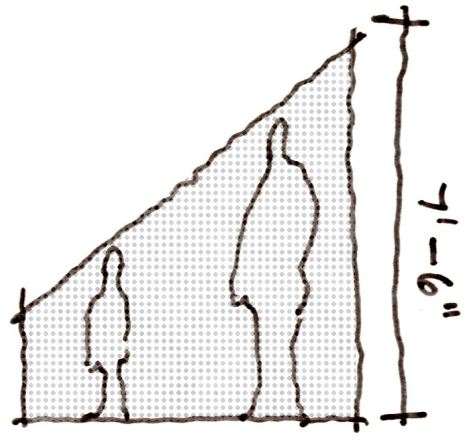

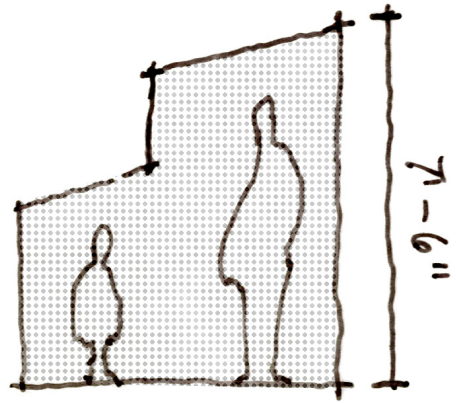

“Only architecture that considers human scale and interaction is successful architecture.”

- Jan Gehl

“Only architecture that considers human scale and interaction is successful architecture.”

- Jan Gehl

“Scale versus the human counterpart”

“Only architecture that considers human scale and interaction is successful architecture.”

- Jan Gehl

“Scale versus the human counterpart”

“collage of textured pieces that increase reaction and retention to place”

“Only architecture that considers human scale and interaction is successful architecture.”

- Jan Gehl

“Scale versus the human counterpart”

“collage of textured pieces that increase reaction and retention to place”

“shift from the typical to an a-typical educational facility”

“Only architecture that considers human scale and interaction is successful architecture.”

- Jan Gehl

“Scale versus the human counterpart”

“collage of textured pieces that increase reaction and retention to place”

“shift from the typical to an a-typical educational facility”

“explores and expresses the fluid reality which children live in and are connected to”

“Only architecture that considers human scale and interaction is successful architecture.”

- Jan Gehl



INTERACTION + SCALE

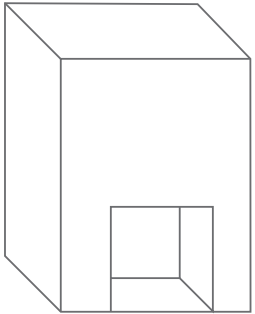

HIDING

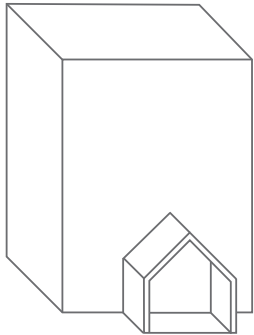

HOUSE PLAY

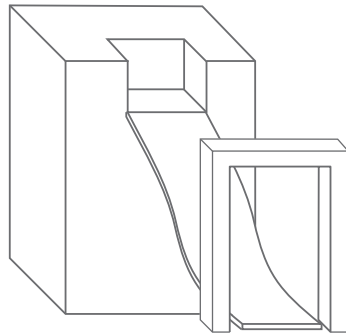

SLIDE

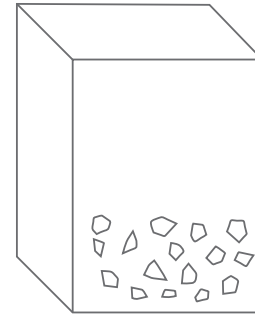

TEXTURE WALL

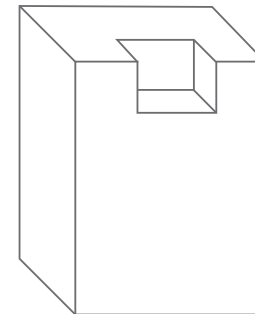

HIGH POINT

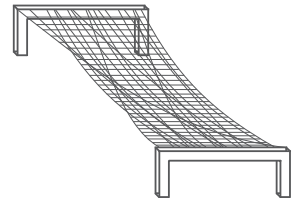

MESH

“explores and expresses the fluid reality which children live in and are connected to”

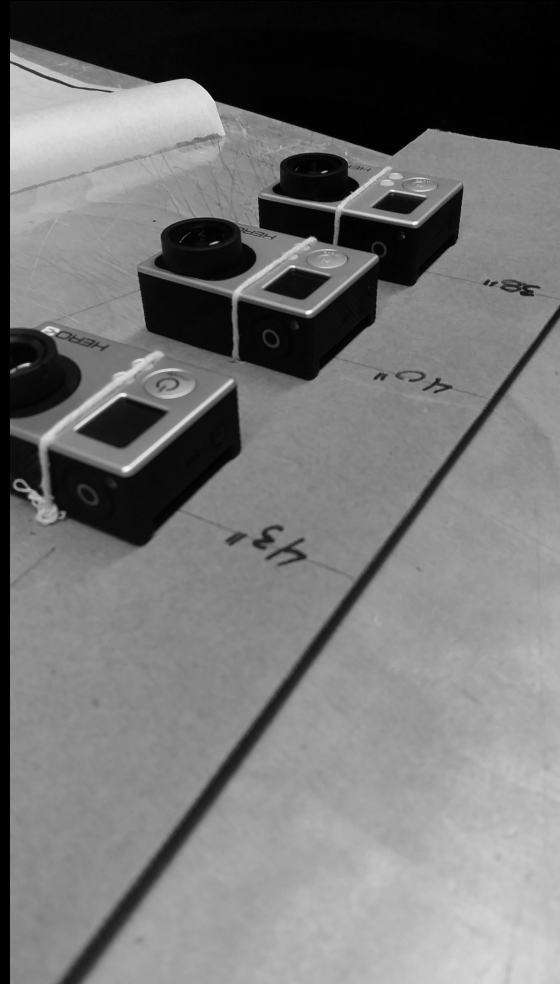



CAMERA FRAMES

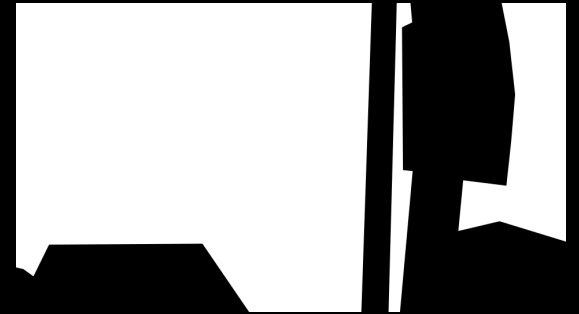
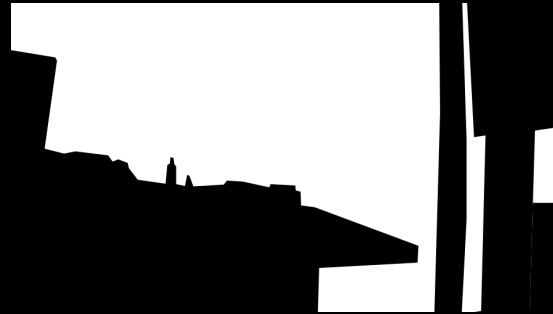
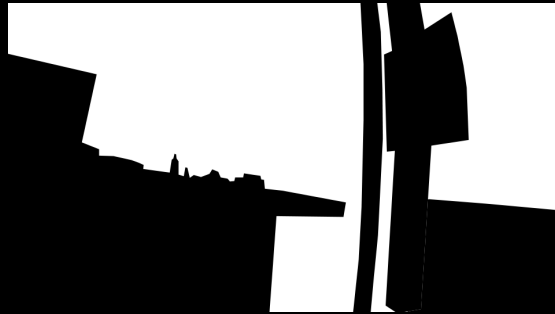
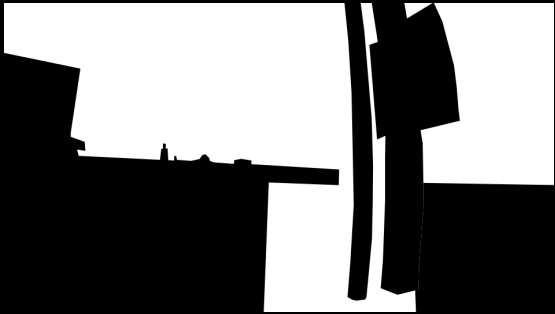

OBSCURED SPACE

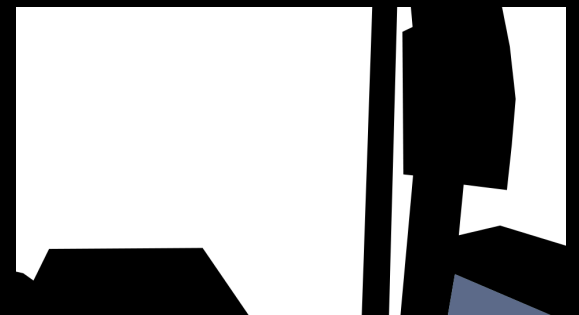
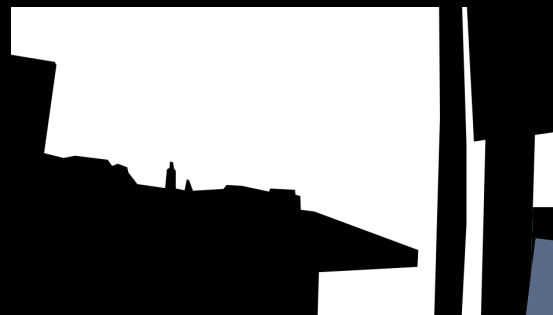
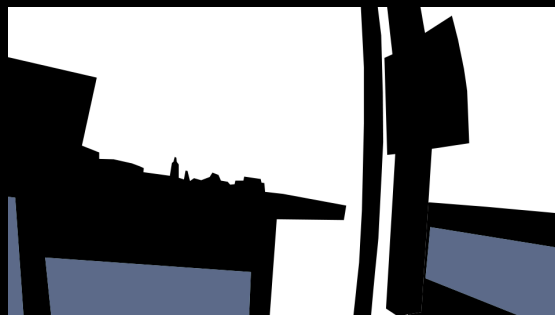
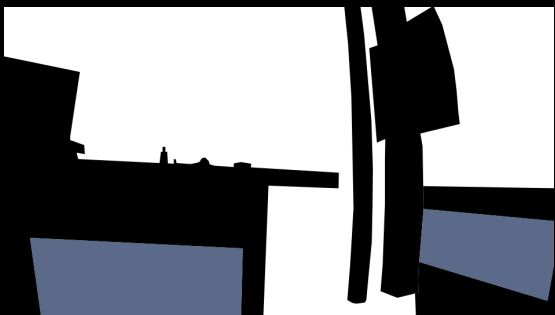

OPPORTUNE SPACE



CAMERA FRAMES

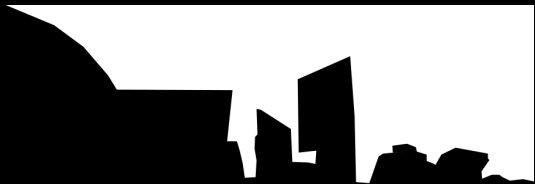

OBSCURED SPACE

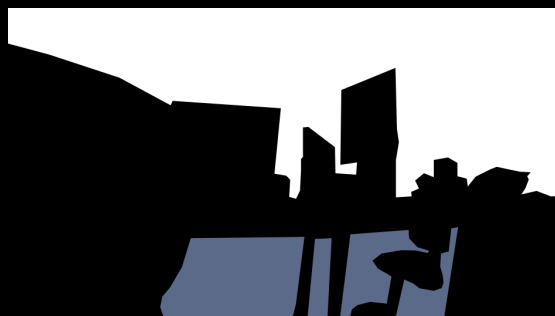

OPPORTUNE SPACE

“Scale versus the human counterpart”

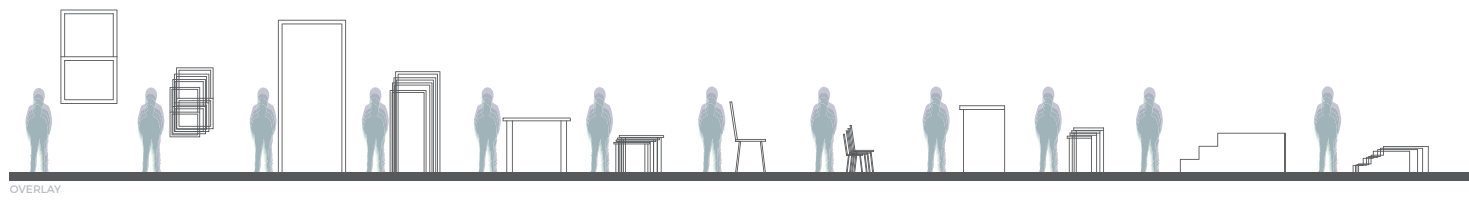
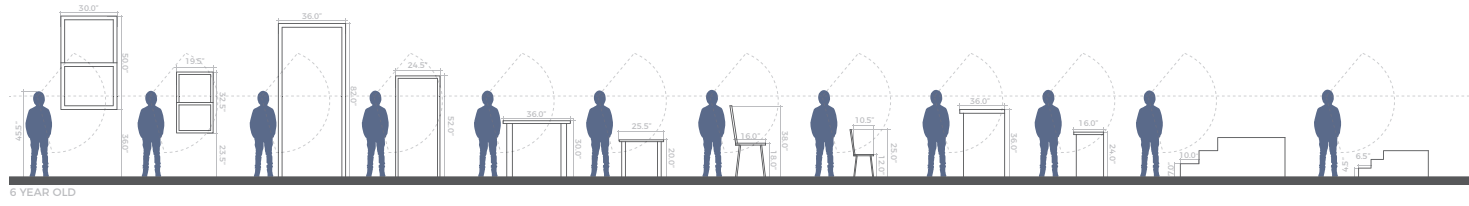
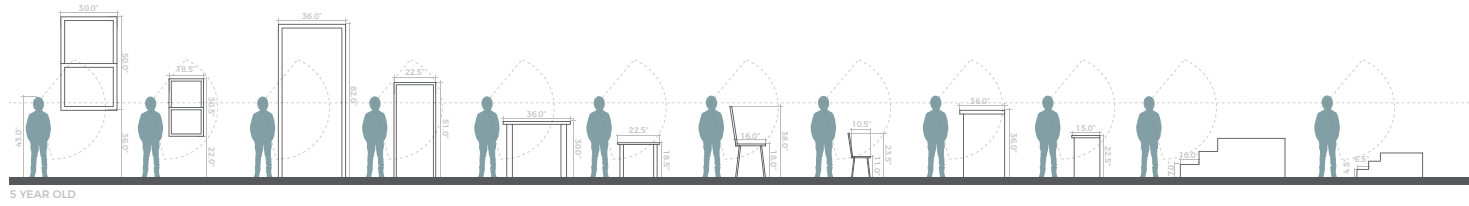
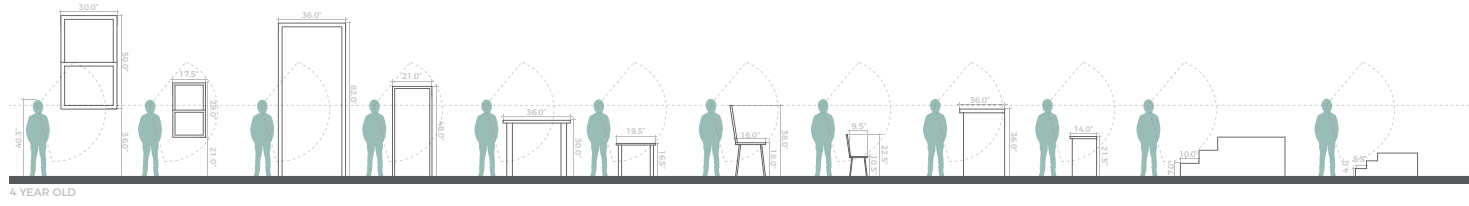
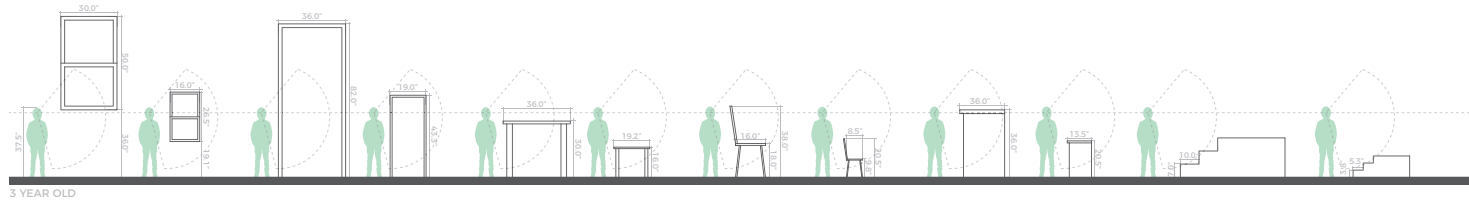

“collage of textured pieces that increase reaction and retention to place”

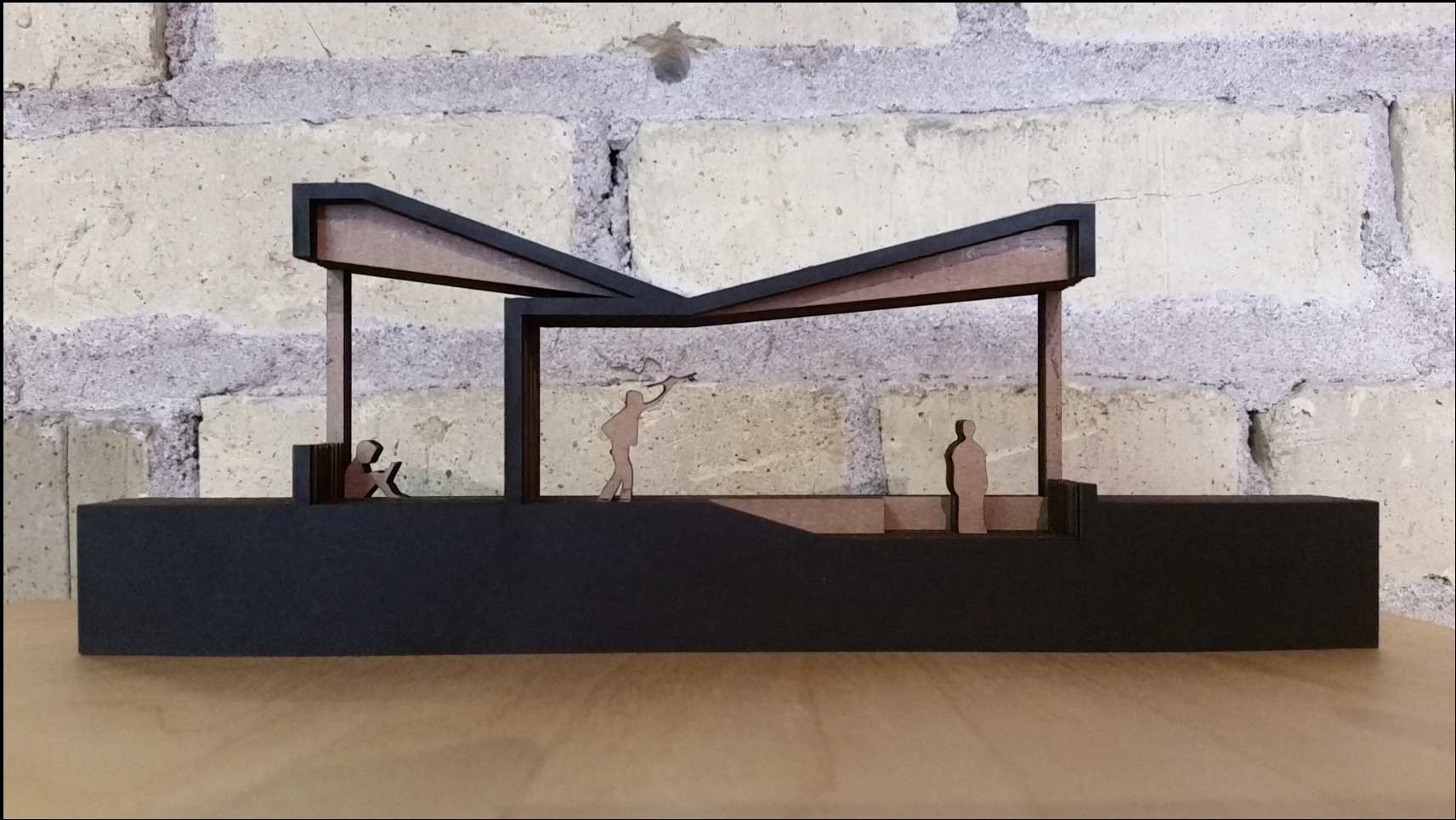





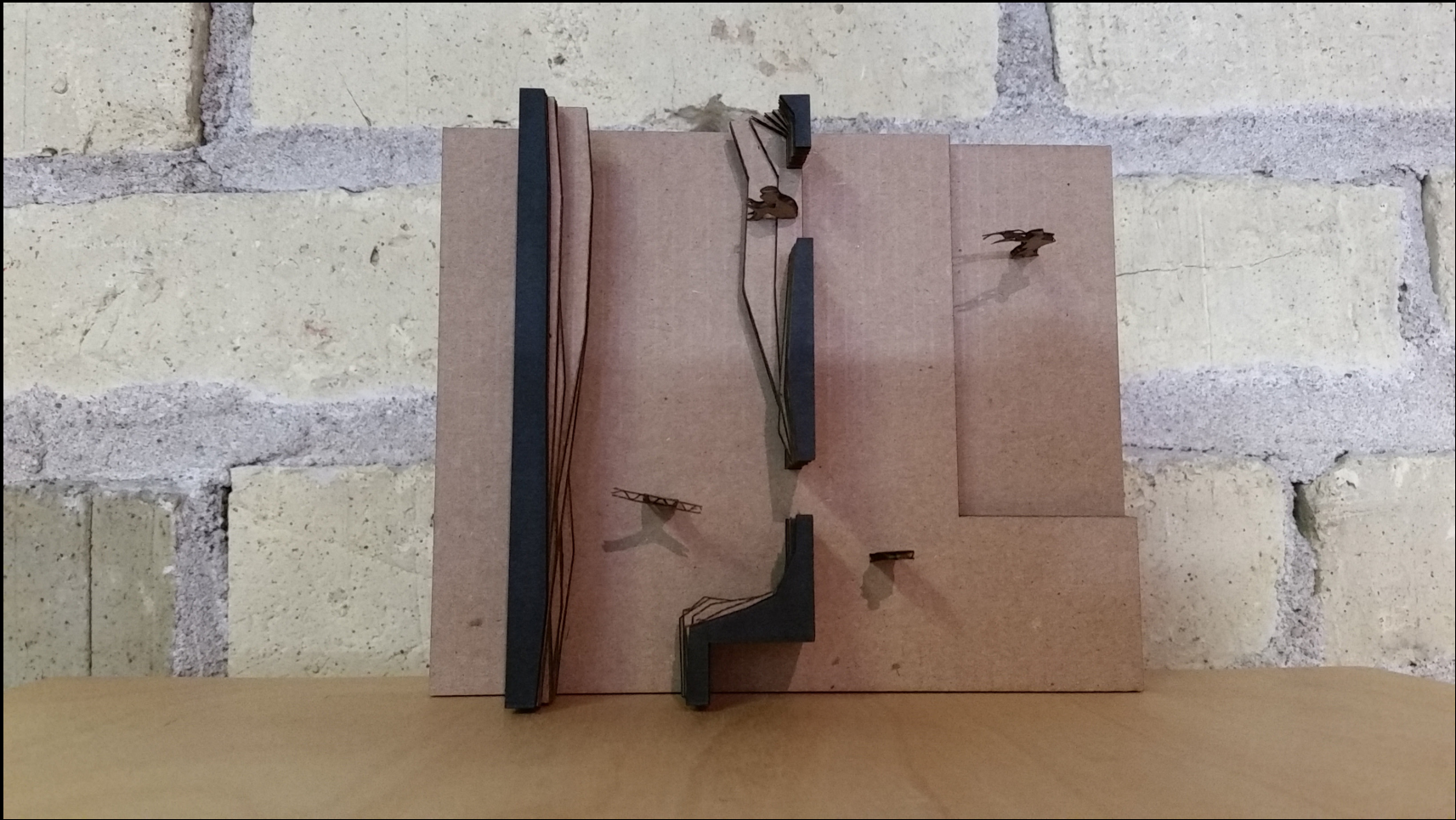



“shift from the typical to an a-typical educational facility”

| | Corning Child Development Center | LeFrak Center at Lakeside | Fukumasu Base and Kindergarten Annex | Hakusui Nursery School | Kindergarten in Guastalla | Delft Montessori School | Raa Day Care Center | The Birds Nest | Borneinstitutioner | Children and Family Center |
|------------------------------|---|---|--|---|--|---|--|---|--|--|
| | New York City, New York | Brooklyn, New York | Chiba Prefecture, Japan | Chiba Prefecture, Japan | Guastalla, Italy | Delft, Netherlands | Kustagatan, Sweden | Randbølvej, Denmark | Amager, Copenhagen | Ludwigsburg, Germany |
| | Late Modern | Earth Integrated | Urban | Earth Integrated | Late Modern | Building Focused | Building Focused | Site Focused | Organic | Rural |
| Spatial Relationships | | | | | | | | | | |
| Entrys and Exits | | | | | | | | | | |
| Circulation | | | | | | | | | | |
| Section / Scale | | | | | | | | | | |
| Aesthetics (Personal) | <ul style="list-style-type: none"> + functional + varying spatial heights + pleasing material palette - unbalanced form - organicism seemingly from nowhere - hodgepodge of color - lack of varied texturing | <ul style="list-style-type: none"> + functional + clean color and lines + pleasing material palette + flows from the earth - lack of functional efficiency across two forms - scaled heights for children and teens | <ul style="list-style-type: none"> + clean exterior architectural line work and form + varying spatial heights + good balance between wood and white - cramped interior spaces - interior wood walls are not functional | <ul style="list-style-type: none"> + functional + varying spatial heights and areas + pleasing material palette reminiscent of a forest - redundant amount of interior steps - hodgepodge of color - spatial efficiency is weak | <ul style="list-style-type: none"> + clean modern lines interior and exterior + varying spatial heights + pleasing material palette - too much symmetry and repetition - organicism seemingly from nowhere and for the wrong audience | <ul style="list-style-type: none"> + functional / highly efficient and collaborative plan + clean corners + minimal color palette - form is restrictive - lacking ample natural light - lacking multiple textures | <ul style="list-style-type: none"> + quality of interior space + varying spatial heights + pleasing material palette - form does not complement context - lacking textural qualities - hodgepodge of color | <ul style="list-style-type: none"> + pleasing material palette + pleasing form - does not complement context - Lacking varying spatial heights - missing textural variance | <ul style="list-style-type: none"> + highly efficient + varying spatial heights - over colored interior - organicism seemingly from nowhere - out of proportion and scale to a child - columns feel under designed | <ul style="list-style-type: none"> + functional + good contextual connection + pleasing material palette + balanced form - varied spatial qualities |
| Color Scheme | | | | | | | | | | |

BORNEINSTITUTIONER, AMAGER, COPENHAGEN

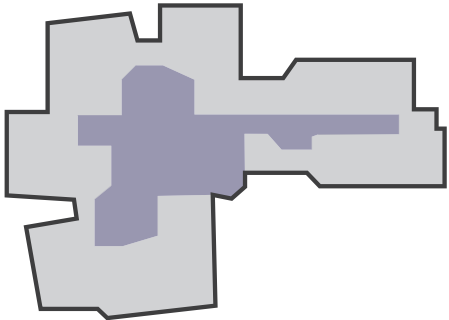

CIRCULATION

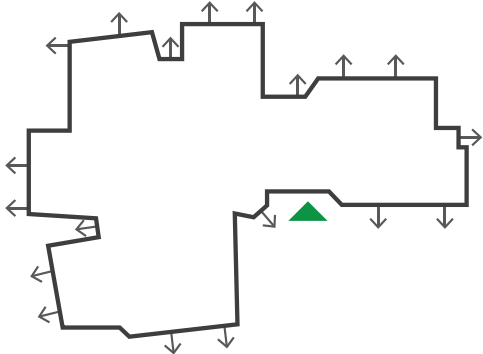

ENTRY AND EXIT

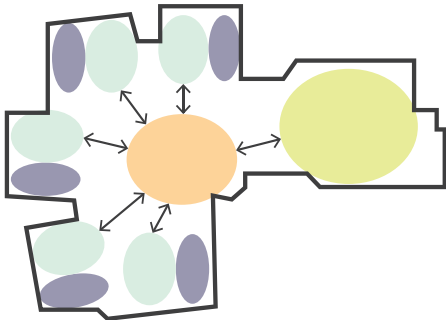

SPACE PROGRAMMING

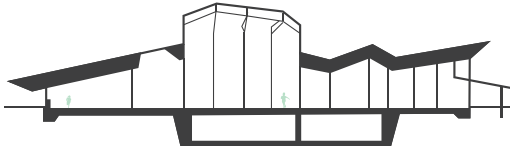

SECTION

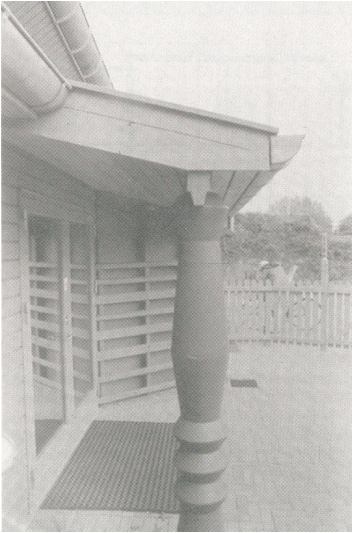

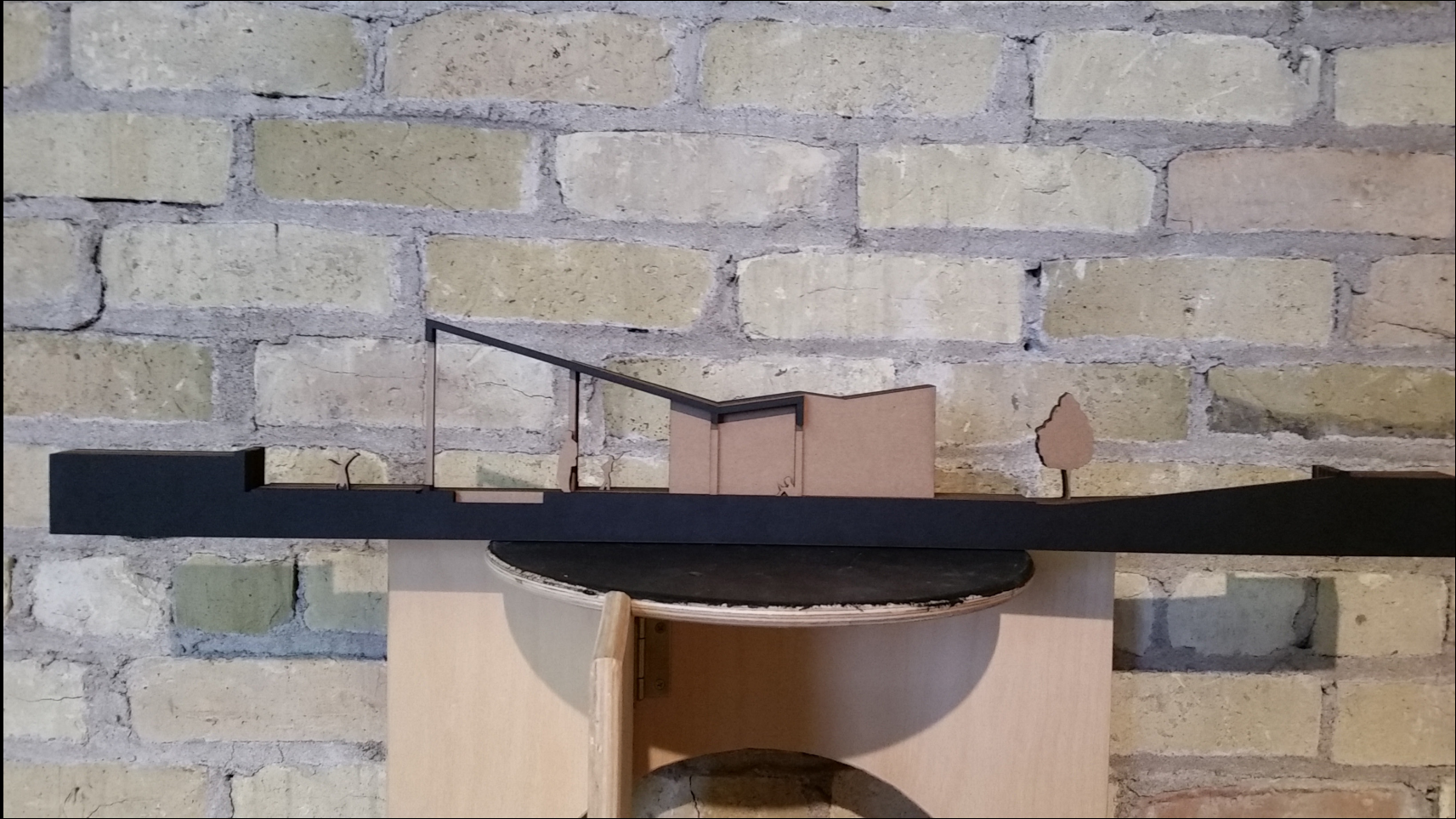

DELFT MONTESSORI, DELFT, NETHERLANDS

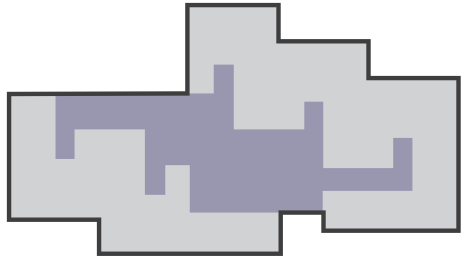

CIRCULATION

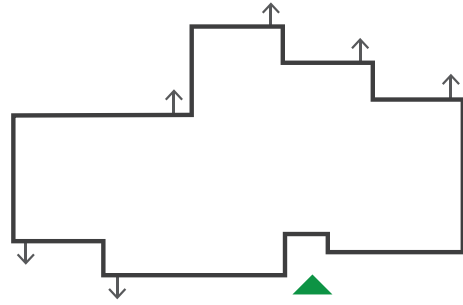

ENTRY AND EXIT

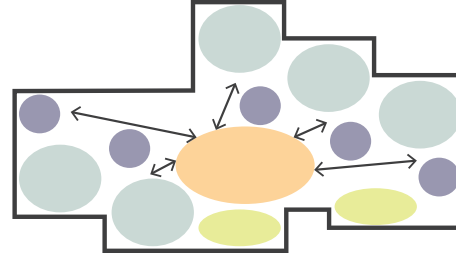

SPACE PROGRAMMING



SECTION

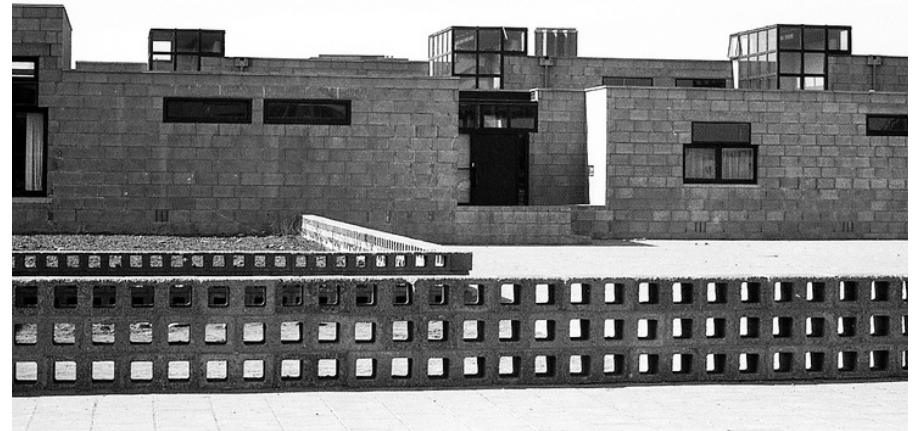

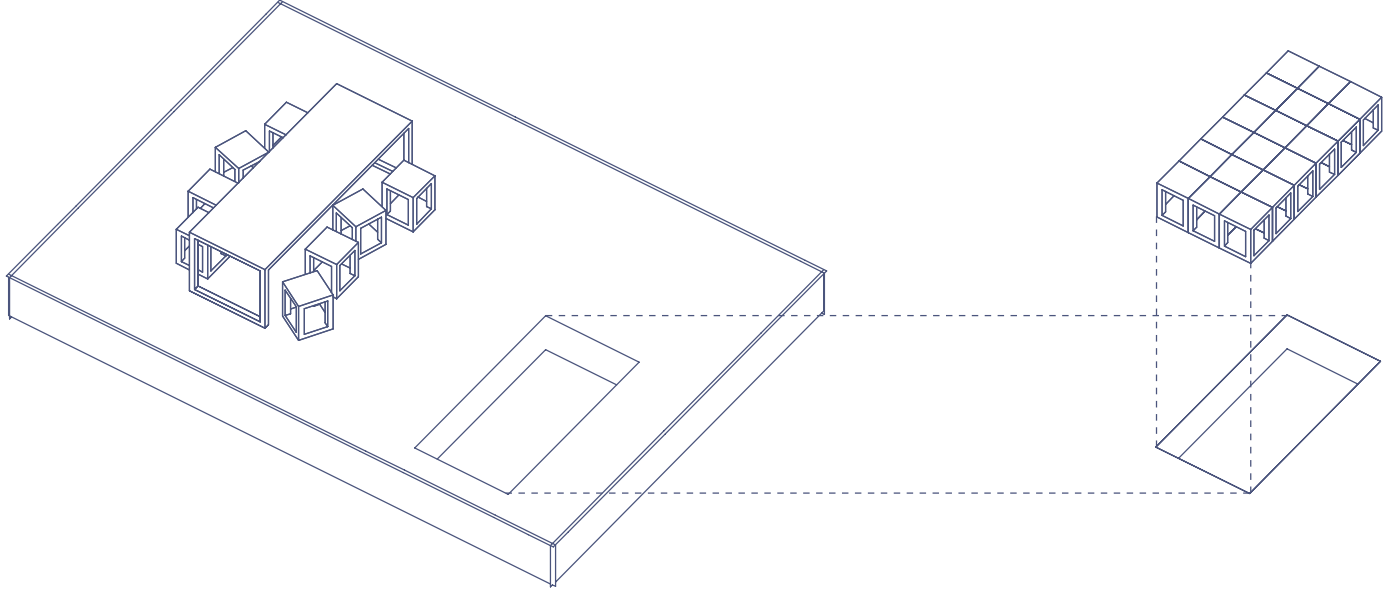

CLASSROOM SEATING

RAA DAY CARE CENTER, RAA, SWEDEN

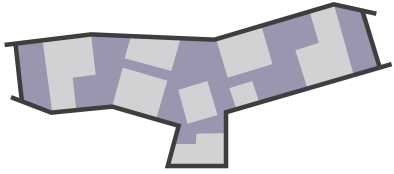

CIRCULATION

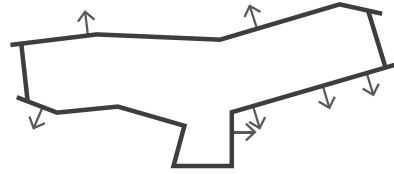

ENTRY AND EXIT

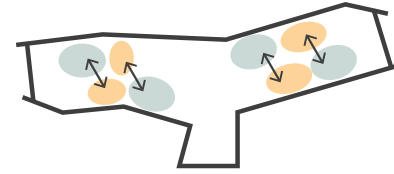

SPACE PROGRAMMING

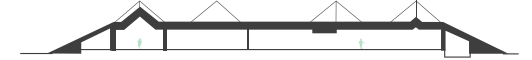

SECTION



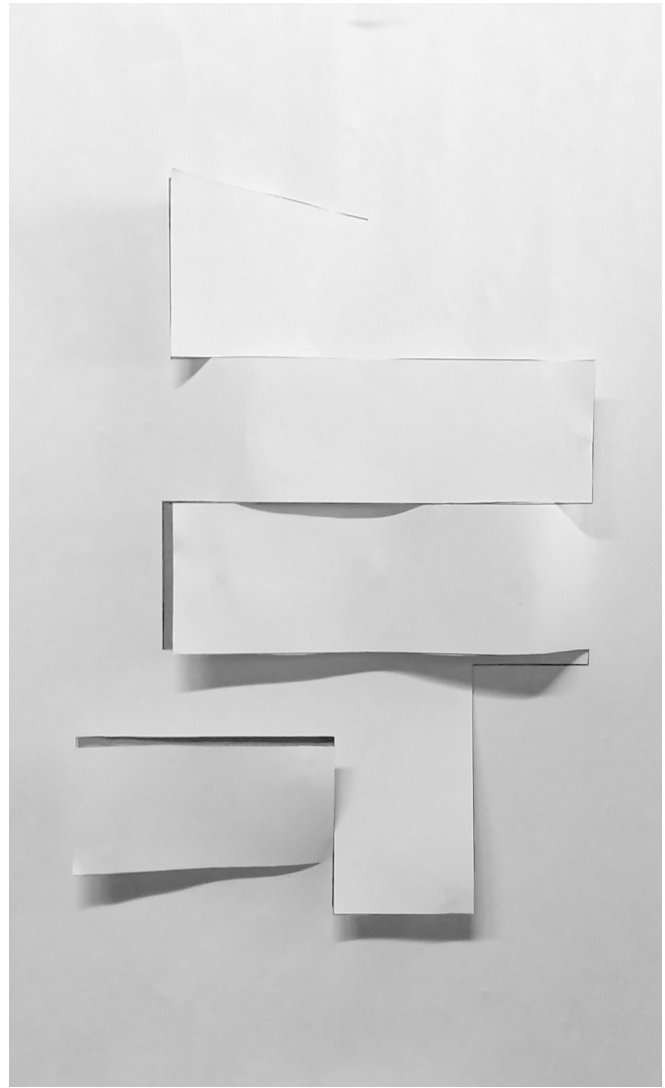

LINE MODELS

Site Analysis

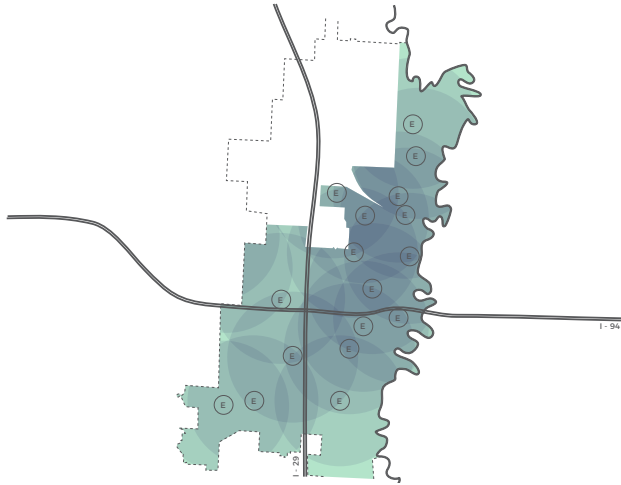

FARGO , ND
POP: 115,863

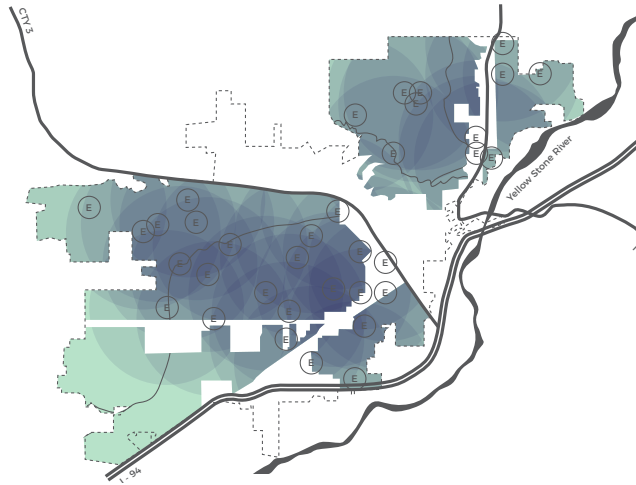

BILLINGS, MT
POP: 108,869

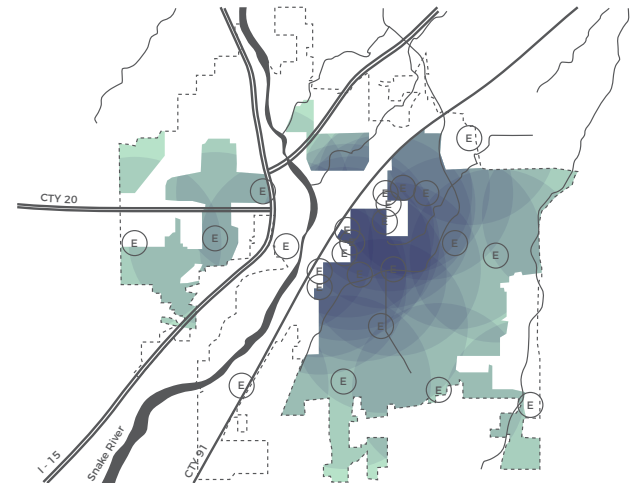

IDAHO FALLS, ID
POP: 58,691



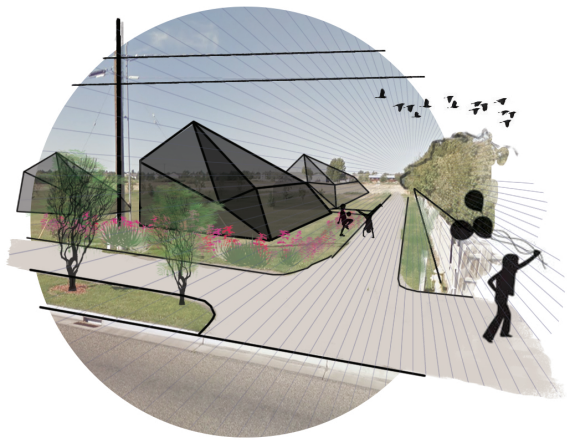

IDAHO FALLS, ID

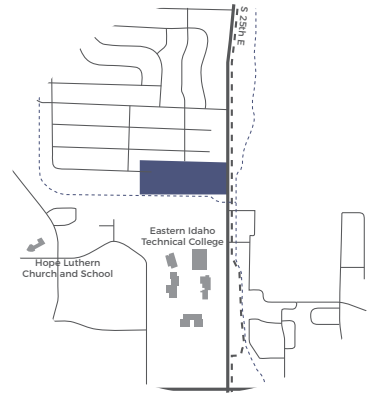

STREET GRID AND IMPORTANT BUILDINGS
1 mi.

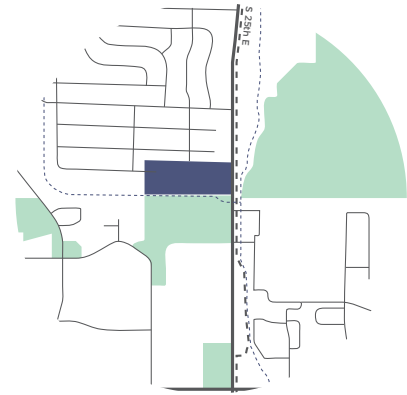

GREEN SPACE AND PEDESTRIAN PATHS
1 mi.

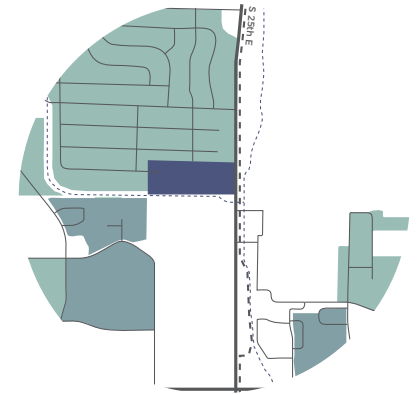

RESIDENTIAL
1 mi.

The Design

GROUND FLOOR PLAN
SCALE: 1/8" = 1' - 0"



- 1. Feature Stair
- 2. Slide
- 3. Reception
- 4. Mechanical
- 5. Staff Work Lounge
- 6. Conference Room
- 7. Directors Office
- 8. Infant Classroom
- 9. Infant Classroom
- 10. Toddler Room
- 11. Gross Motor Room
- 12. Three Year Old Classroom
- 13. Four Year Old Classroom
- 14. Five Year Old Classroom
- 15. Mechanical
- 16. Kitchen Preparation
- 17. Storage

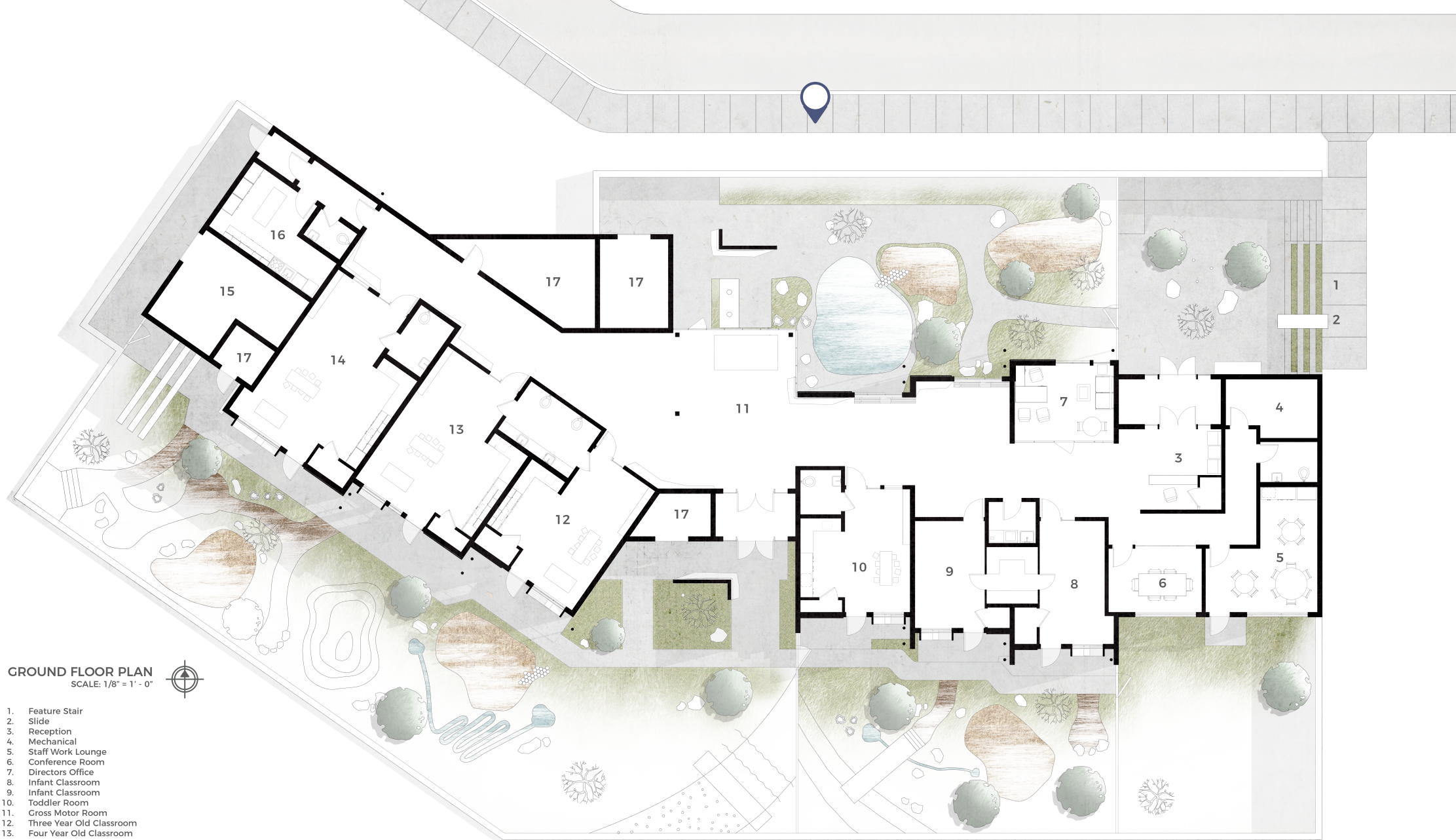



GROUND FLOOR PLAN
SCALE: 1/8" = 1' - 0"



- 1. Feature Stair
- 2. Slide
- 3. Reception
- 4. Mechanical
- 5. Staff Work Lounge
- 6. Conference Room
- 7. Directors Office
- 8. Infant Classroom
- 9. Infant Classroom
- 10. Toddler Room
- 11. Gross Motor Room
- 12. Three Year Old Classroom
- 13. Four Year Old Classroom
- 14. Five Year Old Classroom
- 15. Mechanical
- 16. Kitchen Preparation
- 17. Storage

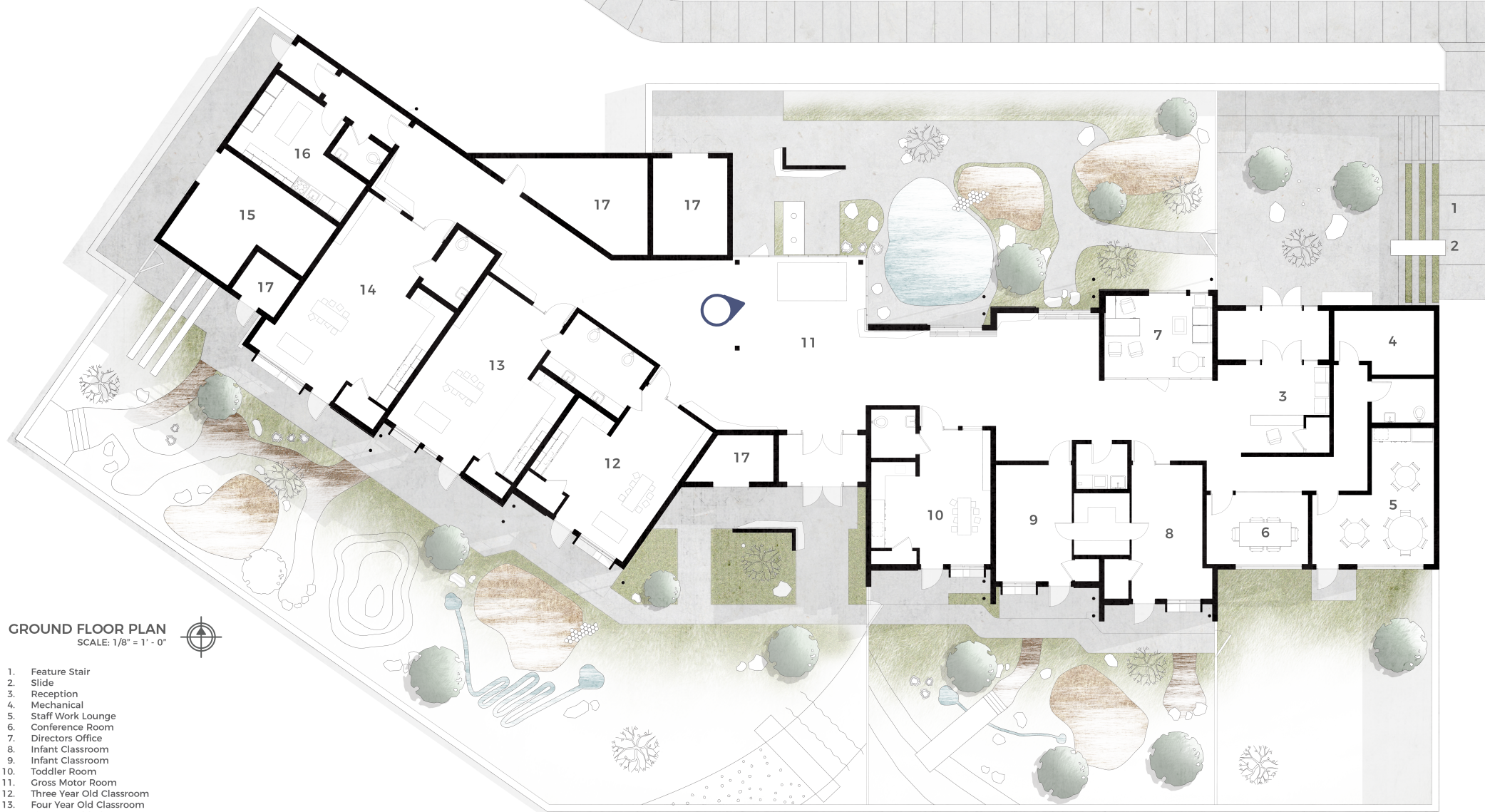



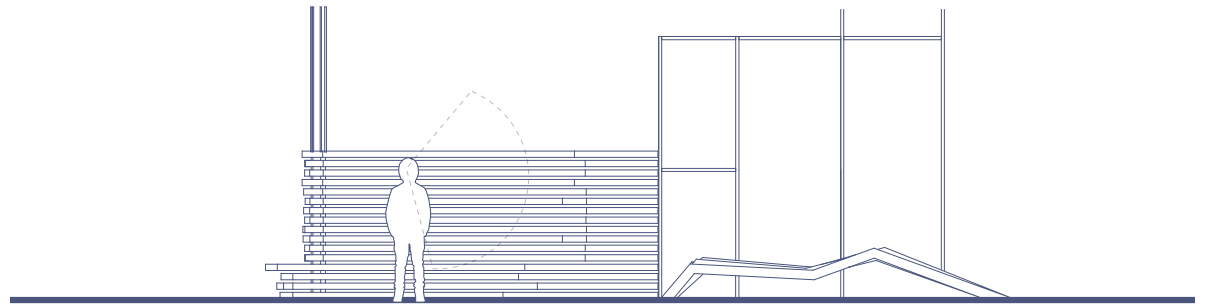
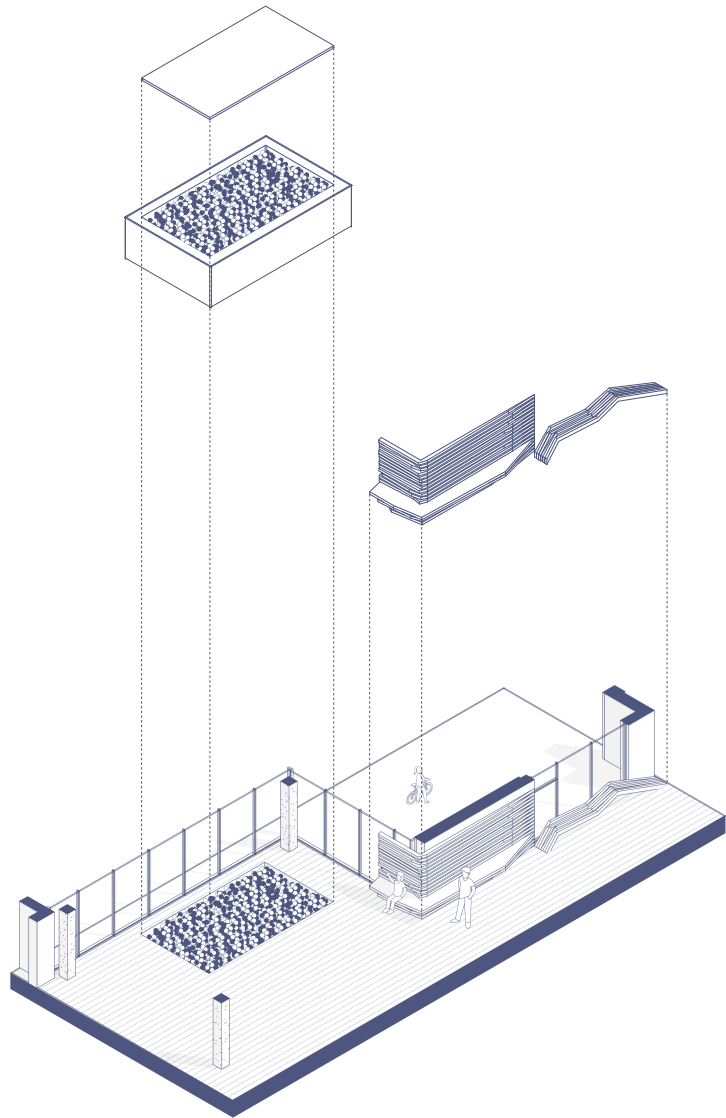

PLAY BENCH W/ CONTOUR WALL

GROUND FLOOR PLAN
SCALE: 1/8" = 1' - 0"



- 1. Feature Stair
- 2. Slide
- 3. Reception
- 4. Mechanical
- 5. Staff Work Lounge
- 6. Conference Room
- 7. Directors Office
- 8. Infant Classroom
- 9. Infant Classroom
- 10. Toddler Room
- 11. Gross Motor Room
- 12. Three Year Old Classroom
- 13. Four Year Old Classroom
- 14. Five Year Old Classroom
- 15. Mechanical
- 16. Kitchen Preparation
- 17. Storage



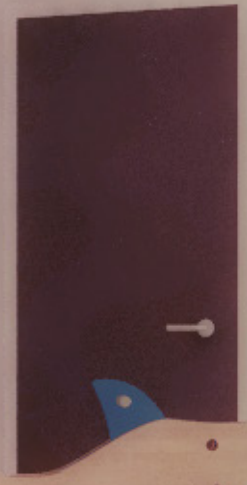
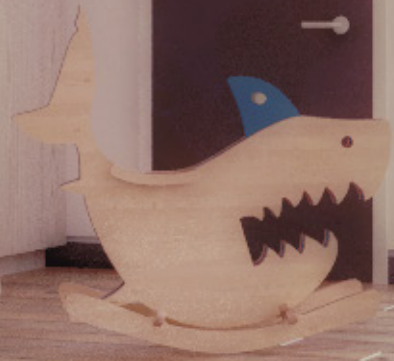

10 3 7 4 6 2

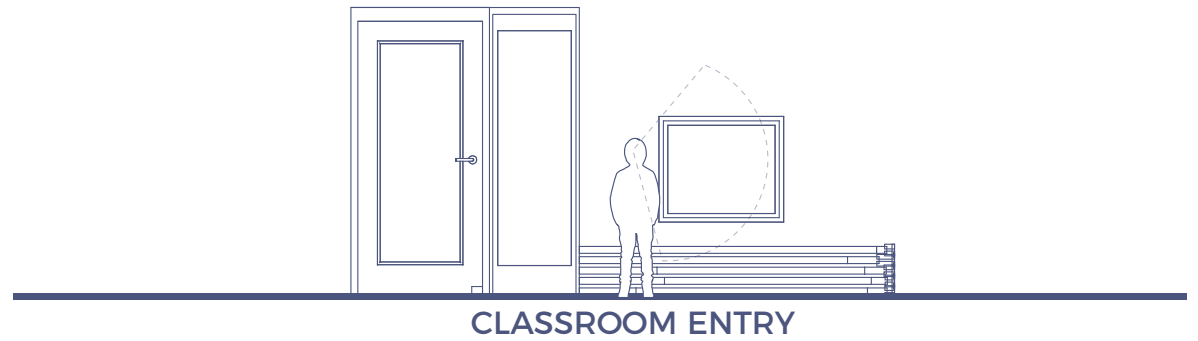
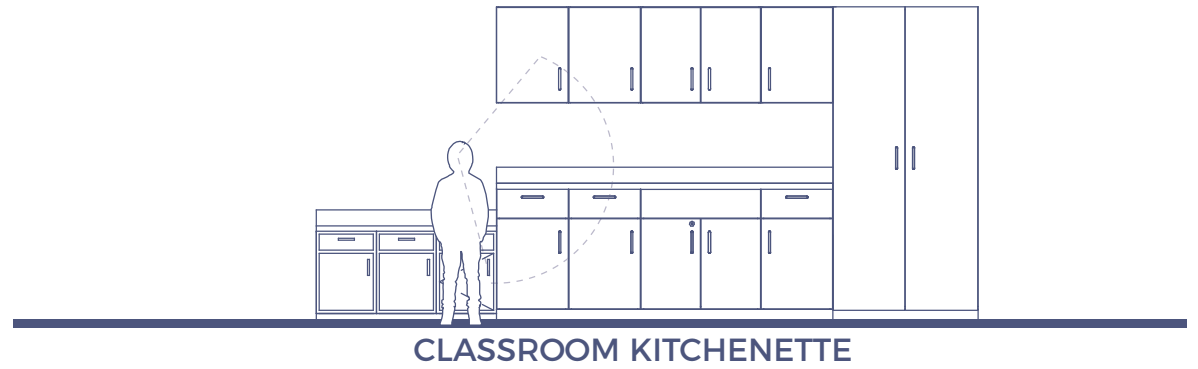
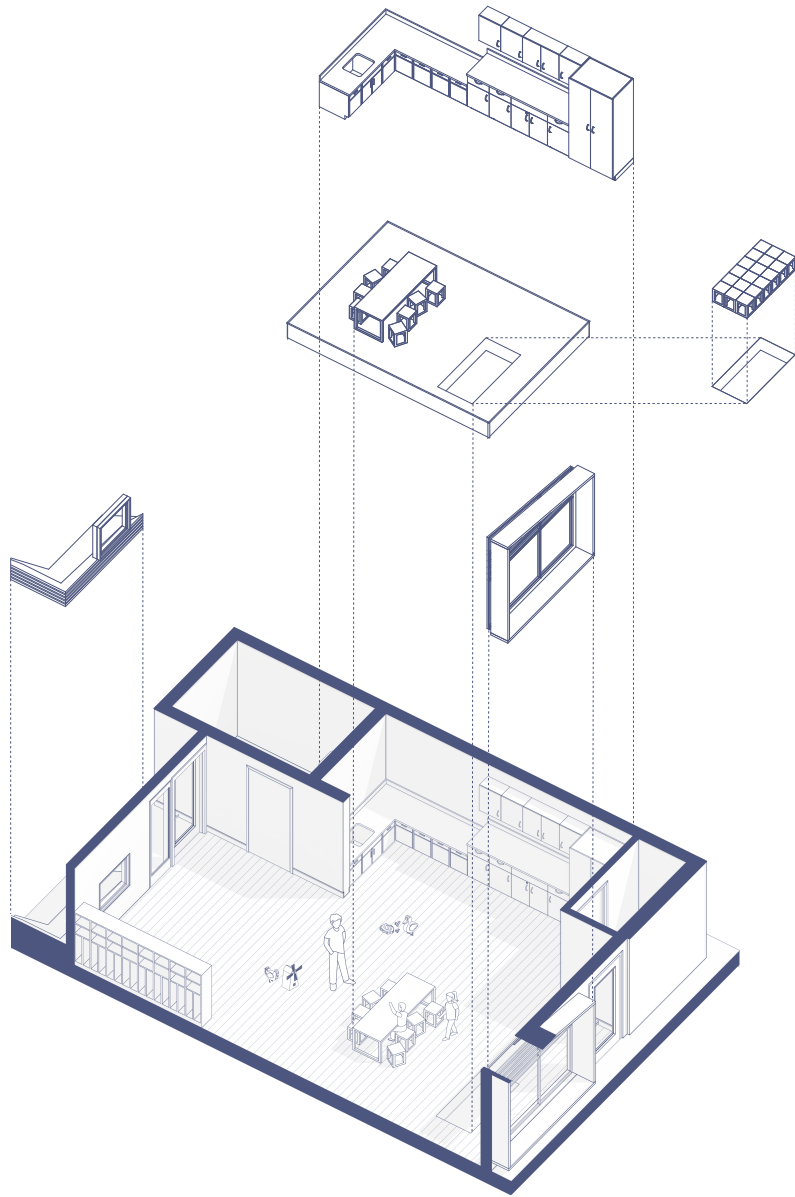

GROUND FLOOR PLAN
SCALE: 1/8" = 1' - 0"



- 1. Feature Stair
- 2. Slide
- 3. Reception
- 4. Mechanical
- 5. Staff Work Lounge
- 6. Conference Room
- 7. Directors Office
- 8. Infant Classroom
- 9. Infant Classroom
- 10. Toddler Room
- 11. Gross Motor Room
- 12. Three Year Old Classroom
- 13. Four Year Old Classroom
- 14. Five Year Old Classroom
- 15. Mechanical
- 16. Kitchen Preparation
- 17. Storage

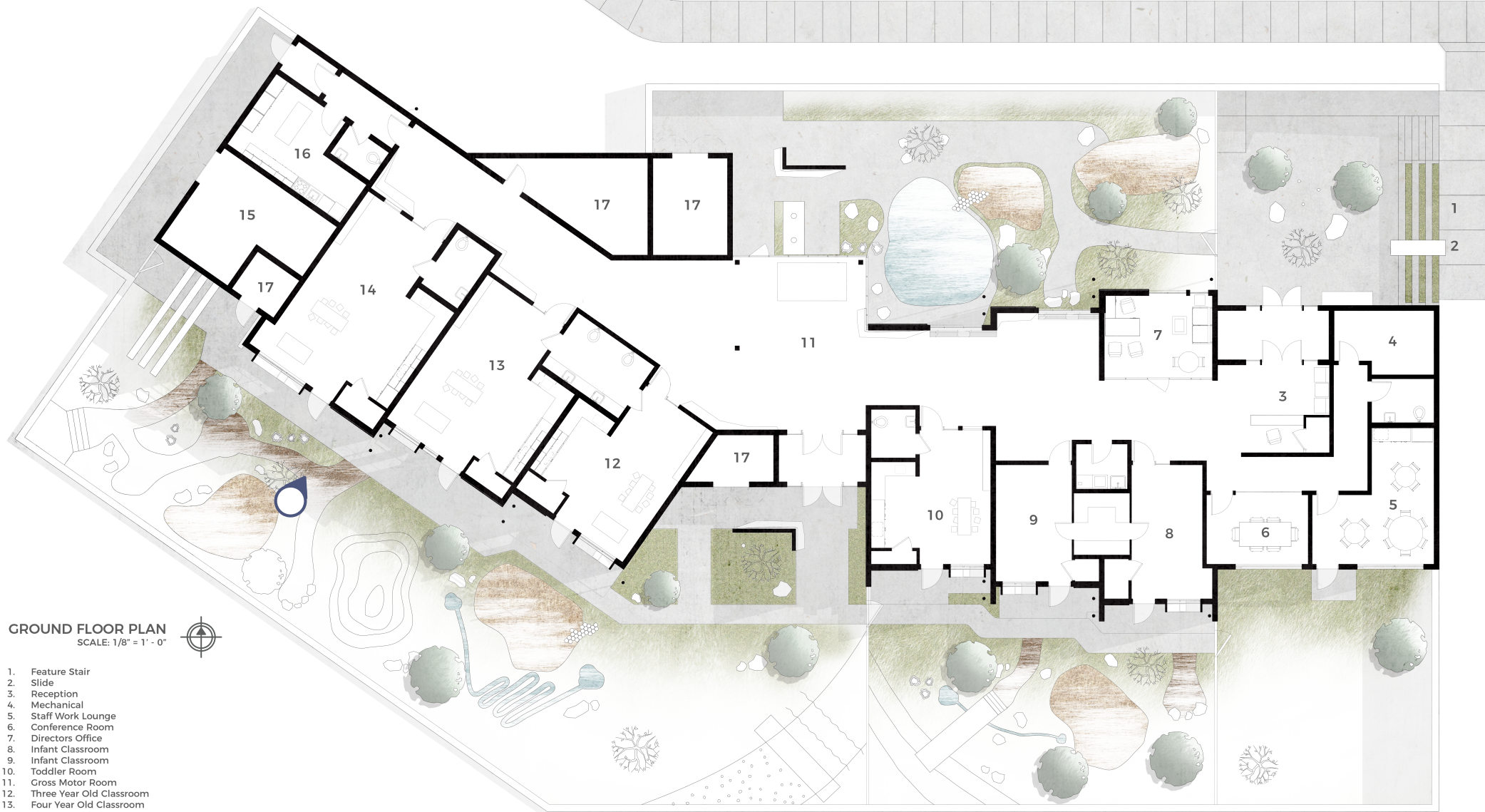



6
5
4
3
2
1

Tina

BETTY

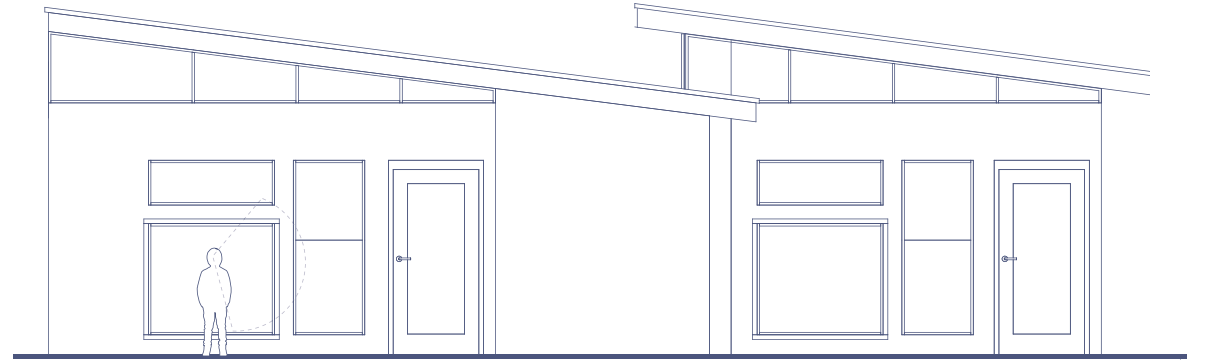
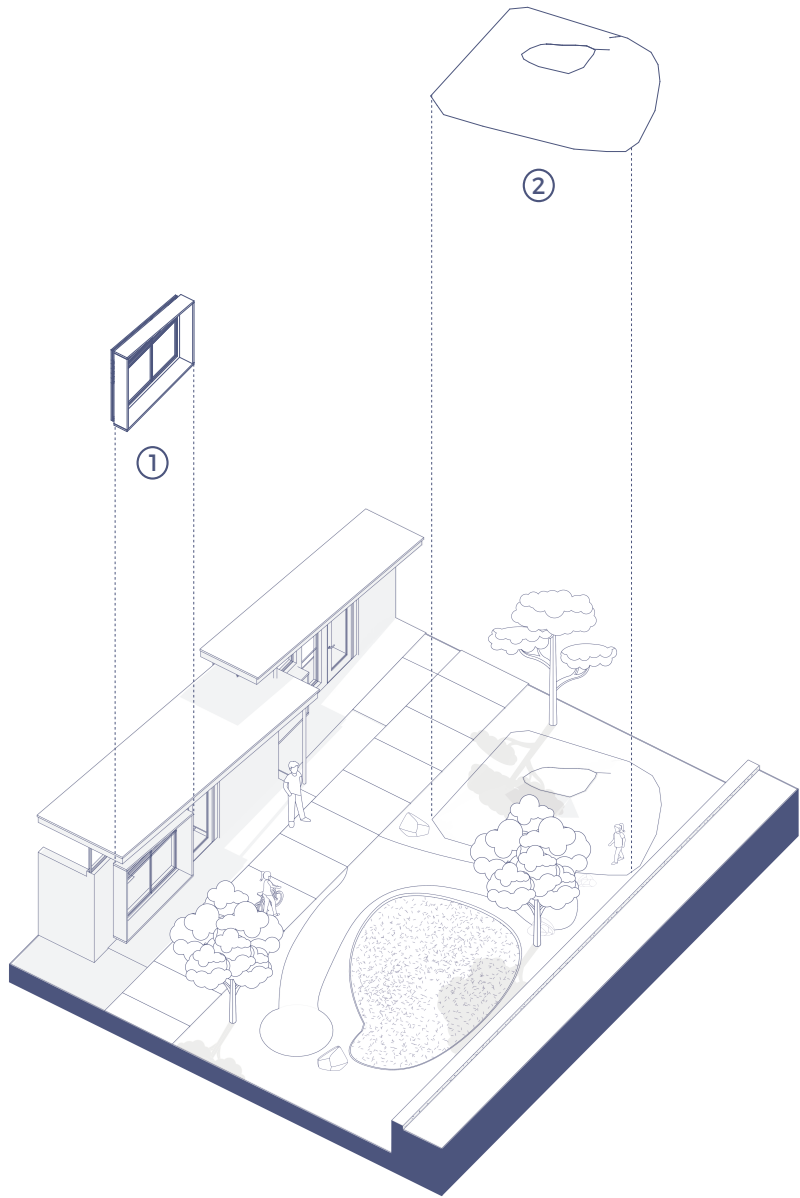

EXTERIOR FACADE

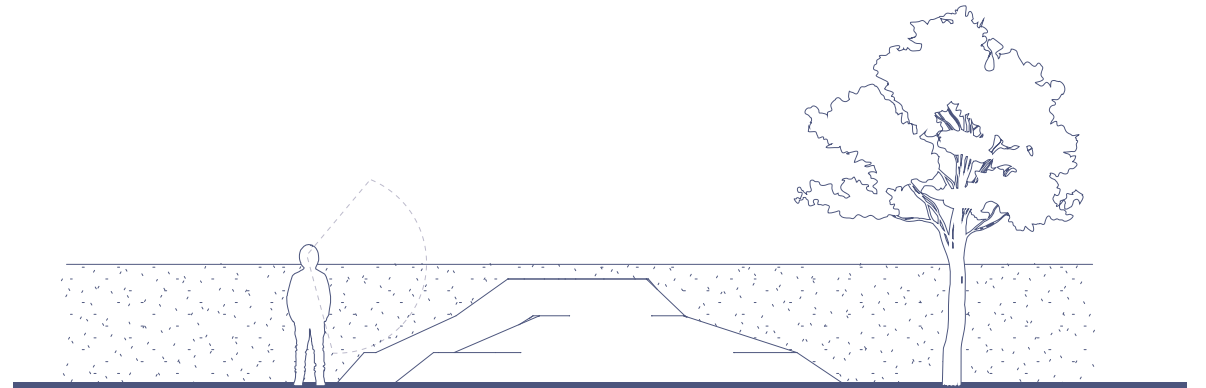

PLAY MOUND

