

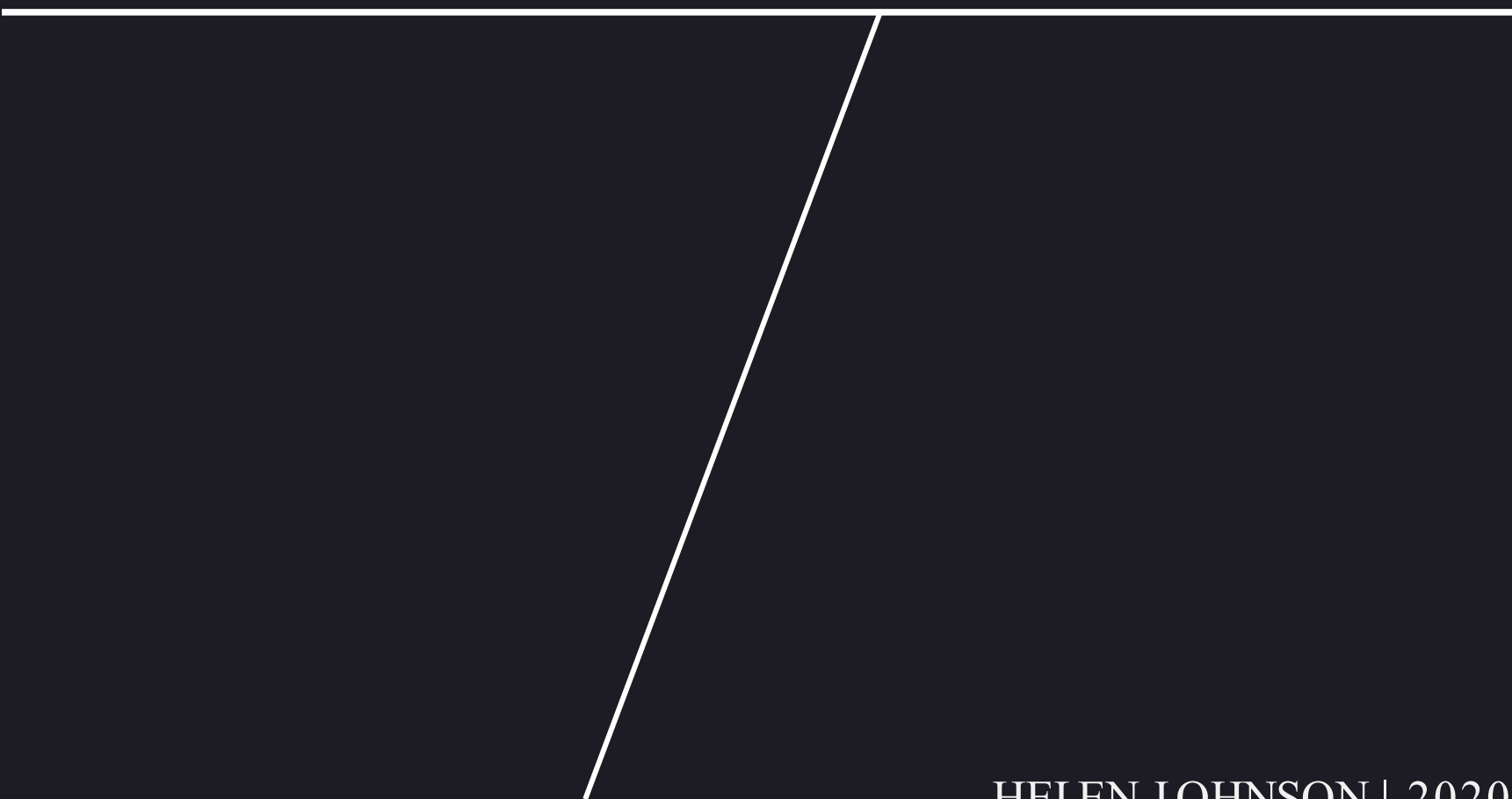



TRANSCENDING BORDERS





I feel as though I live on the border, trying to balance the opposing forces that are pulling me in opposite directions.

← NEW YORK
CANADA →

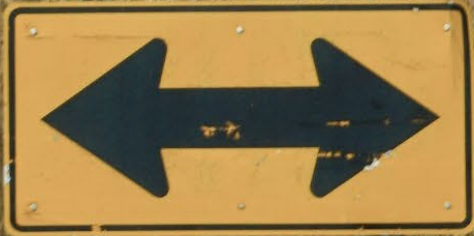

CRAFT FAIR
LEGION #912
ROUSES POINT
DEC. 1ST 10^{AM} - 3^{PM}

CHAD H. DEANS
FOR CLINTON COUNTY
CORONER

ST. PATRICKS
CRAFT SALE

NOV. 2 & 3
SAT. 9 - 2
SUN. 9 - 2

JASON BORRIE
CHAMPLAIN TOWN COUNCIL

← CHRISTMAS WITH MOM
CHRISTMAS WITH DAD →





CRAFT FAIR
LEGION #912
ROUSES POINT
DEC. 1ST 10^{AM} - 3^{PM}

CHAD H. DEANS
FOR CLINTON COUNTY
CORONER

ST. PATRICKS
CRAFT SALE
NOV. 2 & 3
SAT. 9 - 2
SUN. 9 - 2

JASON BORRIE
CHAMPLAIN TOWN COUNCIL

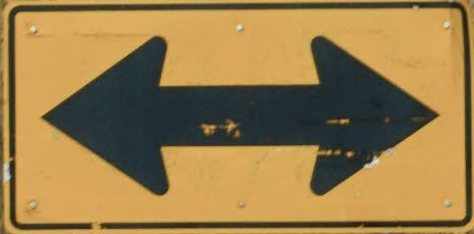
← DRINK RESPONSIBLY
DON'T BE A PARTY
POOPER →



CRAFT FAIR
LEGION #912
ROUSES POINT
DEC. 1ST 10^{AM} - 3^{PM}

CHAD H. DEANS
FOR CLINTON COUNTY
CORONER

ST.
PATRICKS
CRAFT
SALE
NOV. 2 & 3
SAT. 9 - 2
SUN. 9 - 2

**JASON
BORRIE**
CHAMPLAIN TOWN COUNCIL

← PUT OTHERS FIRST
DO WHAT'S BEST
FOR YOU →





CRAFT FAIR
LEGION #912
ROUSES POINT
DEC. 1st 10^{am} - 3^{pm}

CHAD H. DEANS
FOR CLINTON COUNTY
CORONER

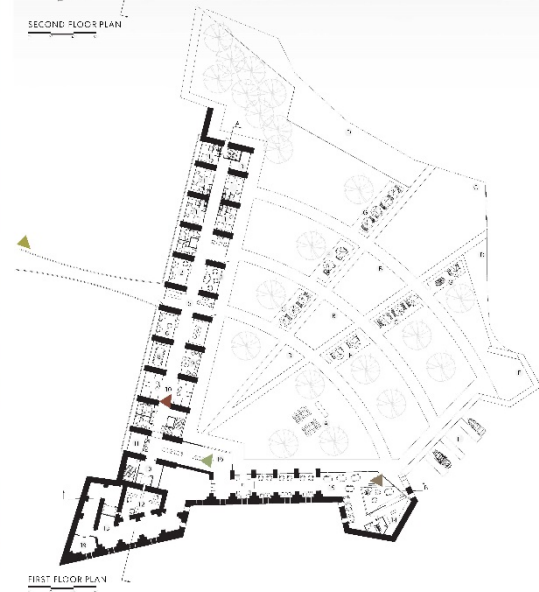
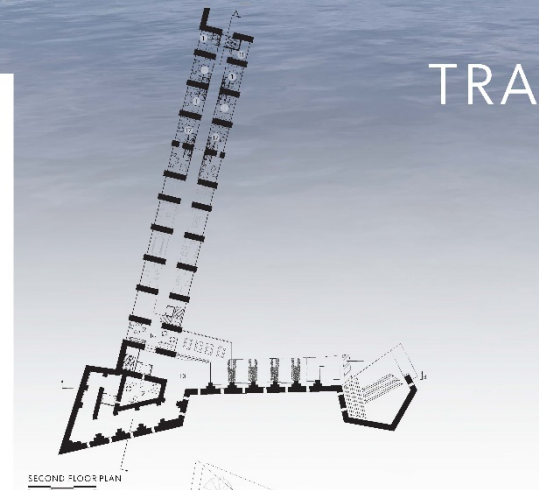
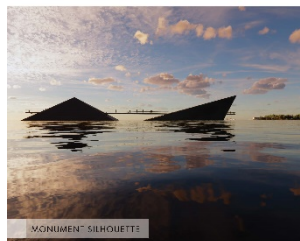
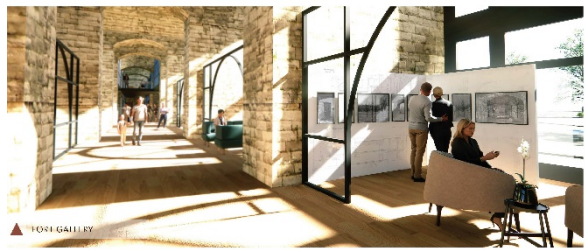

ST. PATRICKS
CRAFT SALE
NOV. 2 & 3
SAT. 9 - 2
SUN. 9 - 2

JASON BORRIE
CHAMPLAIN TOWN COUNCIL

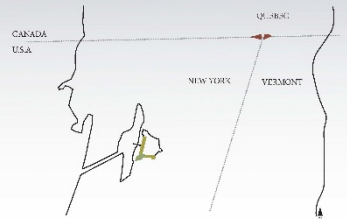

Despite the popularity of border issues in today's media, the spatial transcendence, which borders create, remains unrecognized. This thesis discusses the relationship between architecture and borders. Looking at a border through the lens of a designer offers a variety of perspectives into the different ways in which individuals and societies cross borders. From this perspective, they are no longer looked at as a line, but as a tool, which humans created to bring order to chaos within the mind and the physical world.

"Transcending Borders" creates a common ground where exclusive societies can cross borders as one. This is architecturally expressed as a museum, retreat center, and a monument on a historical site intersecting national and international borders. The project demonstrates that the space a border creates cultivates community while maintaining identity, diversity, security, and a sense of place.



The site is located on Lake Champlain at the invisible intersection of the borders between Quebec, New York, and Vermont and on an abandoned military fort that lies just south of this intersection in New York.

Fortification on the border began shortly after the War of 1812 due to increased military activity from the British Dominion of Canada to protect the waterway into the United States. Construction on Fort Montgomery began in the summer of 1844. Photographs of the ruins left behind are shown at the bottom of the board.

The project defines a border as something that separates, divides, and organizes unique spaces, excludes or includes unique groups, and can be crossed either psychologically or physically. The diagram below illustrates how the three main program components correlate to the definition of a border.

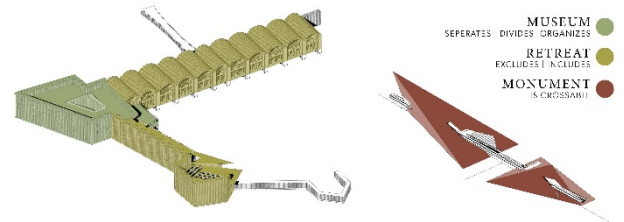

MUSEUM
SEPARATES DIVIDES ORGANIZES

RETREAT
EXCLUDES INCLUDES

MONUMENT
EXCLUDES INCLUDES

- RETIRES ROOM 1
- RETREAT OFFICE 2
- AWN. CAB 3
- RETREAT LOBBY 4
- RETIRES 5
- MUSEUM OFFICE 6
- MUSEUM GIFT SHOP 7
- CONFERENCE ROOM 8
- MUSEUM LOBBY 9
- CAFE 10
- MUSEUM 11
- GUN MUSEUM 12
- MUSEUM 13
- RESTAURANT 14
- RETIRES 15
- ANNUAL MONUMENT WING 16
- PRESIDENTIAL RETREAT ROOMS 17
- SMALL EVENT SPACE 18
- OUTDOOR WEDDING SPACE & SWIMMING POOL 19
- RETIRES 20
- INFINITY POOL 21
- BLANCH 22
- TELESCOPE PLATFORM 23
- INFINITY GATHERING SPACE 24
- SOCIAL GATHERING SPACE 25
- RESTAURANT DOCKING 26

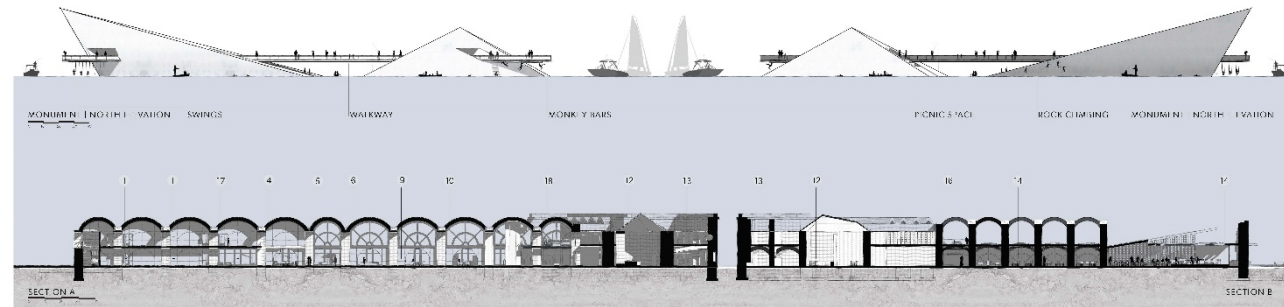





A BORDER...

- SEPARATES | DIVIDES | ORGANIZES
- EXCLUDES | INCLUDES
- IS CROSSABLE

A BORDER...

- SEPARATES | DIVIDES | ORGANIZES
- EXCLUDES | INCLUDES
- IS CROSSABLE

A BORDER...

- SEPARATES | DIVIDES | ORGANIZES
- EXCLUDES | INCLUDES
- IS CROSSABLE



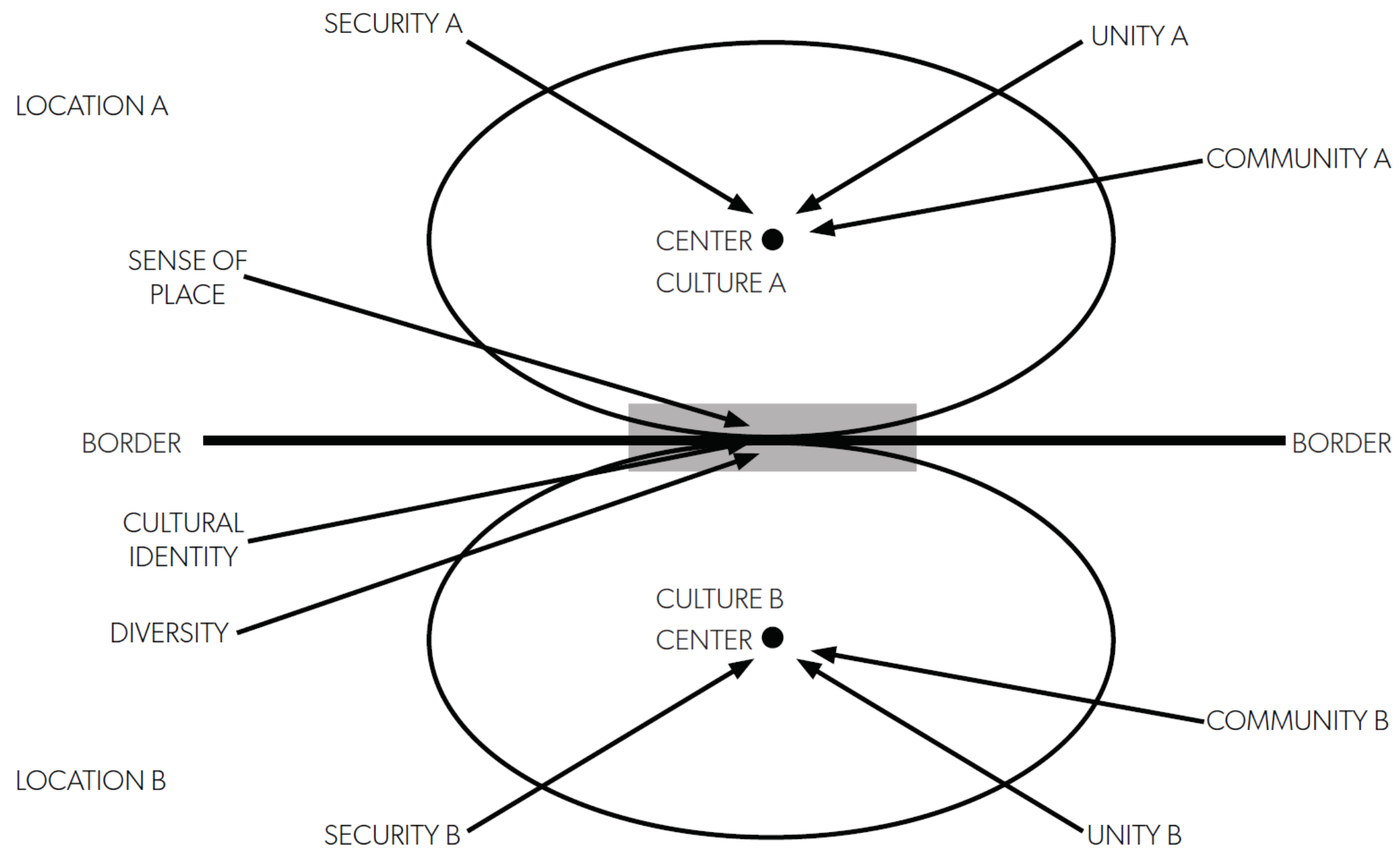

DIAGRAM 1

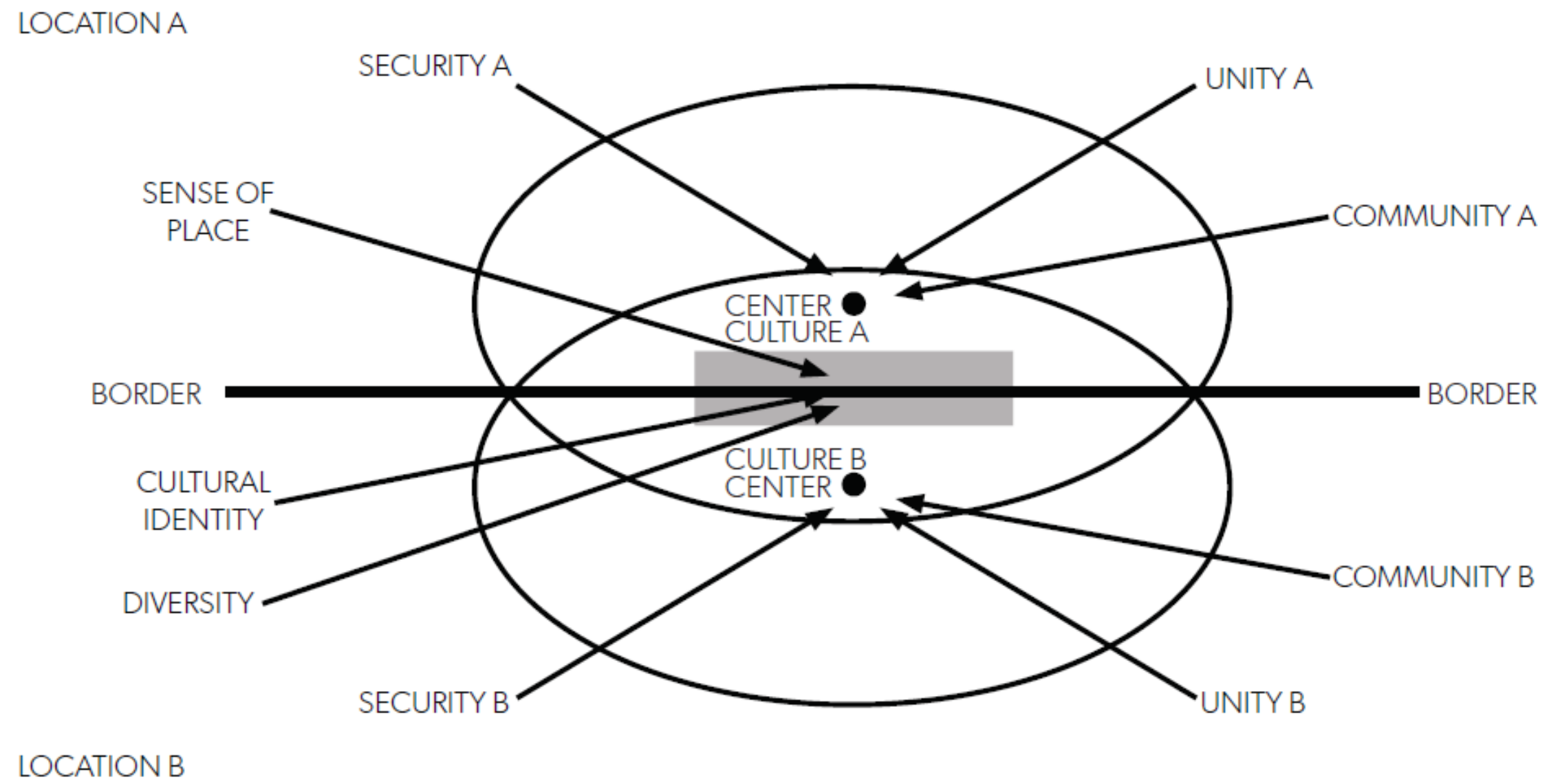
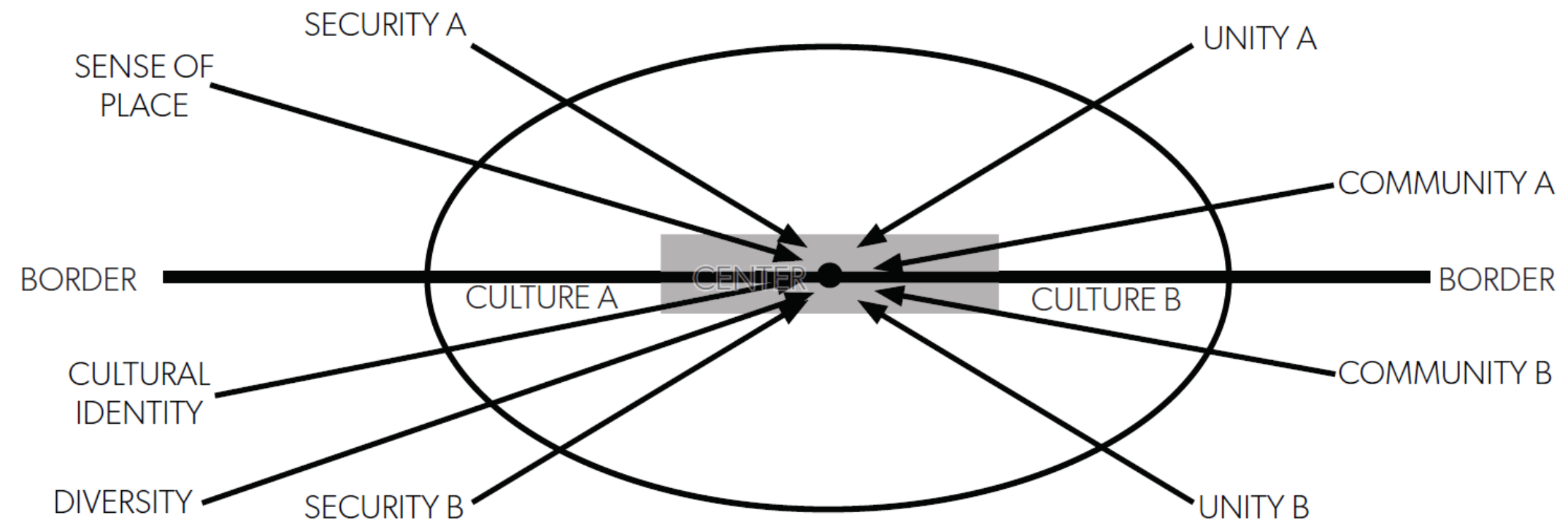

DIAGRAM 2



LOCATION A



LOCATION B

DIAGRAM 3



DIAGRAM 3

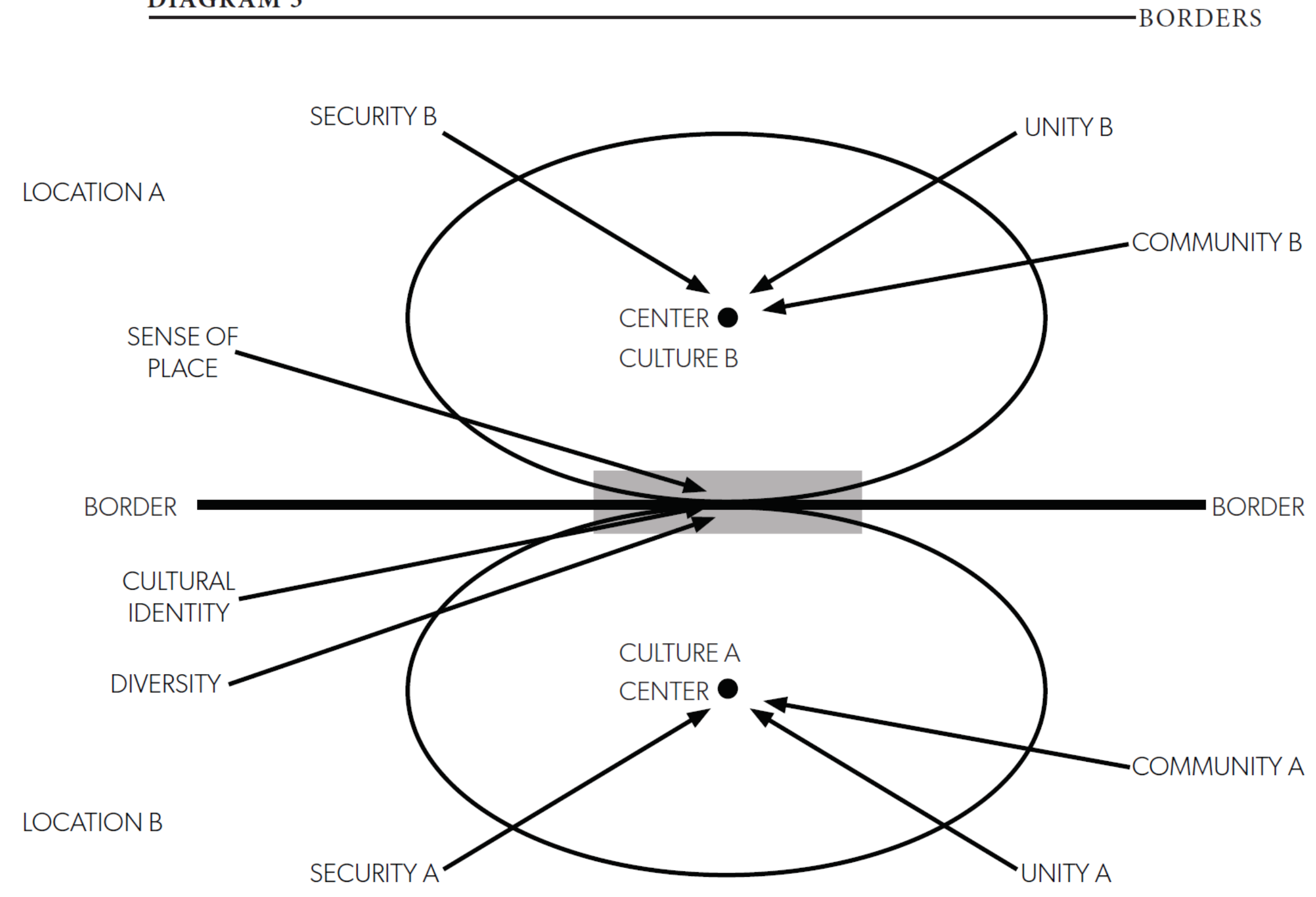
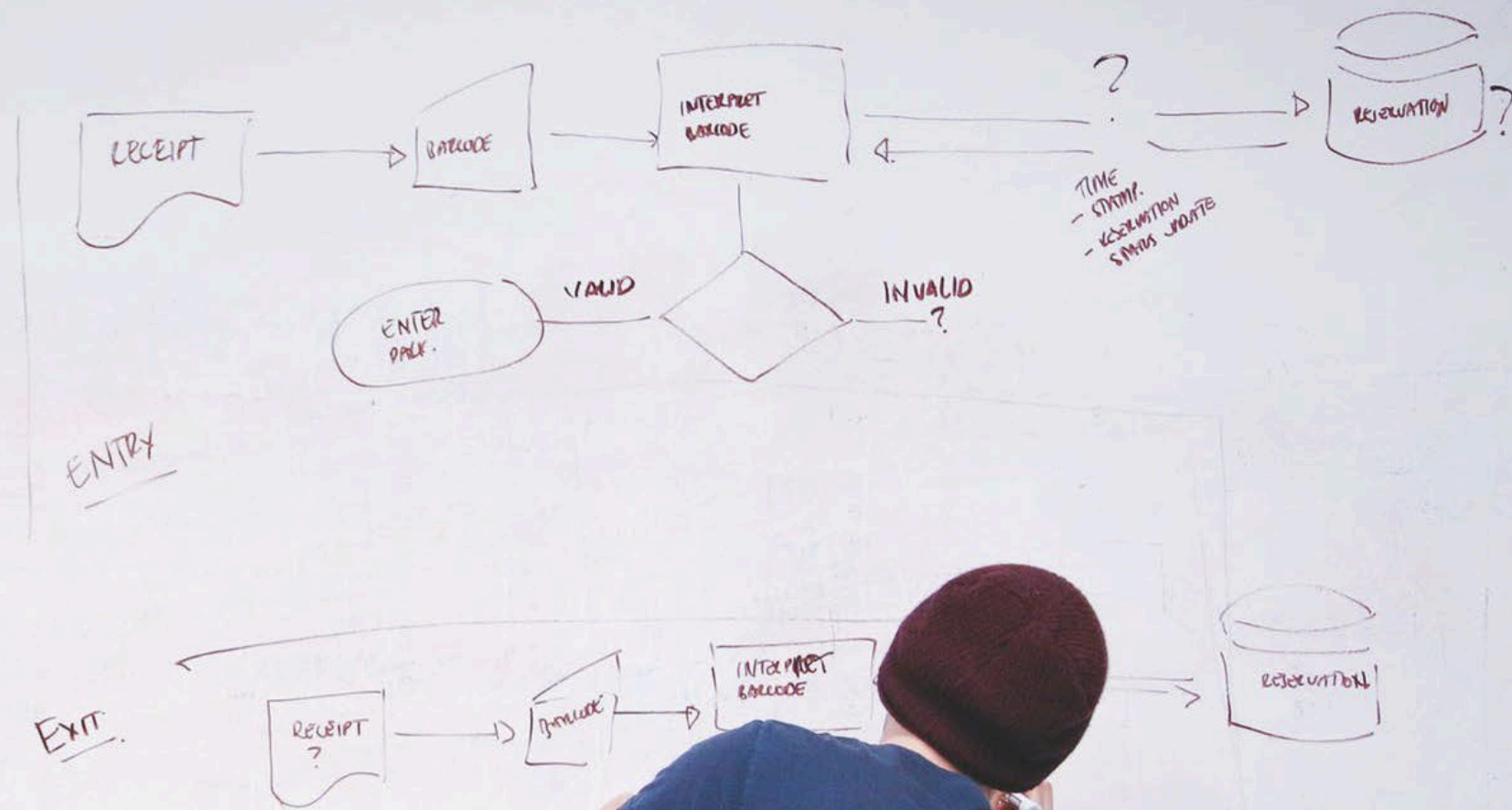
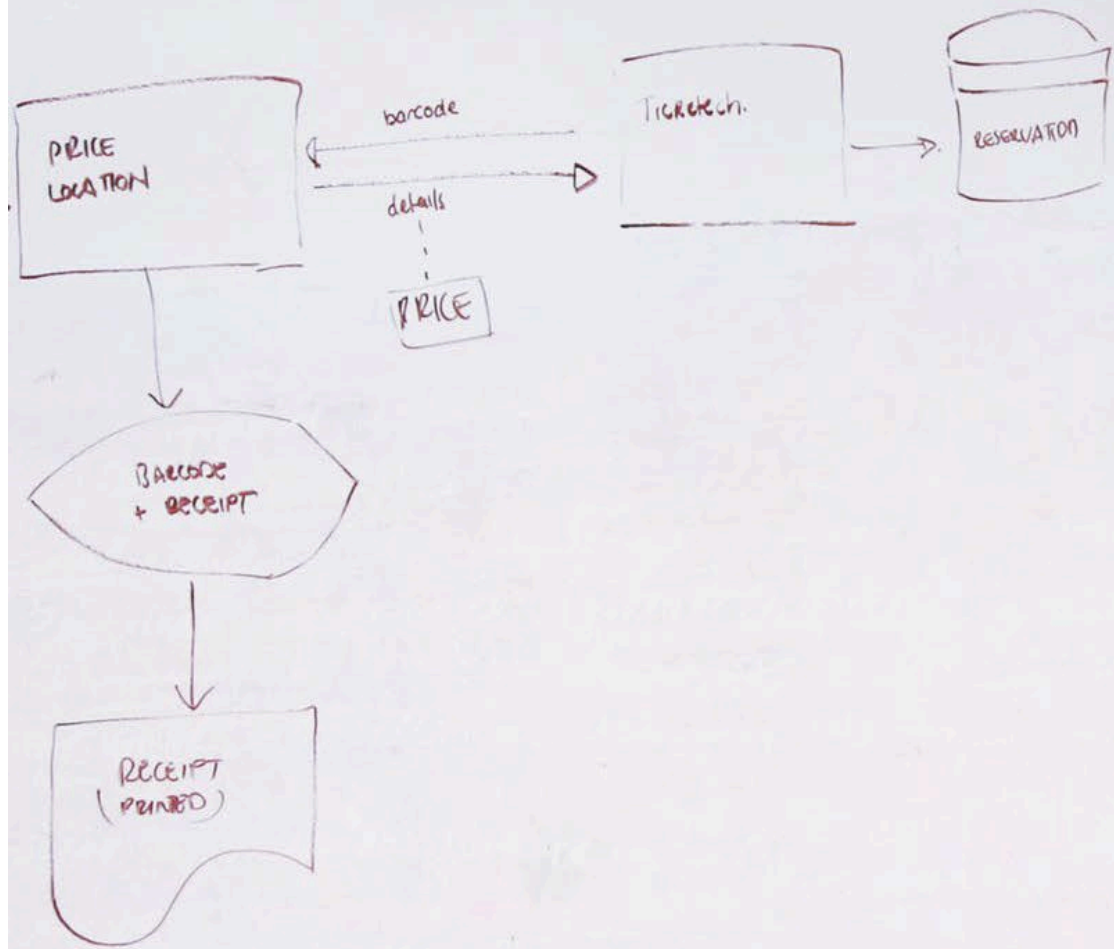
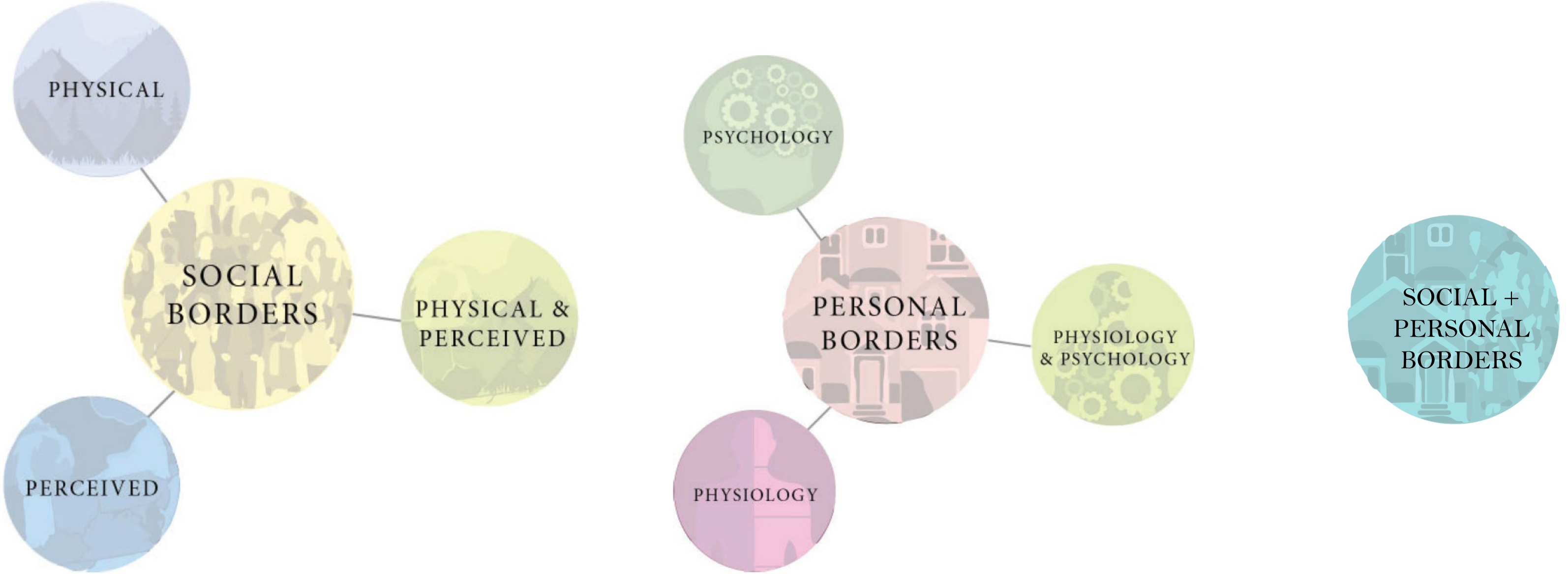
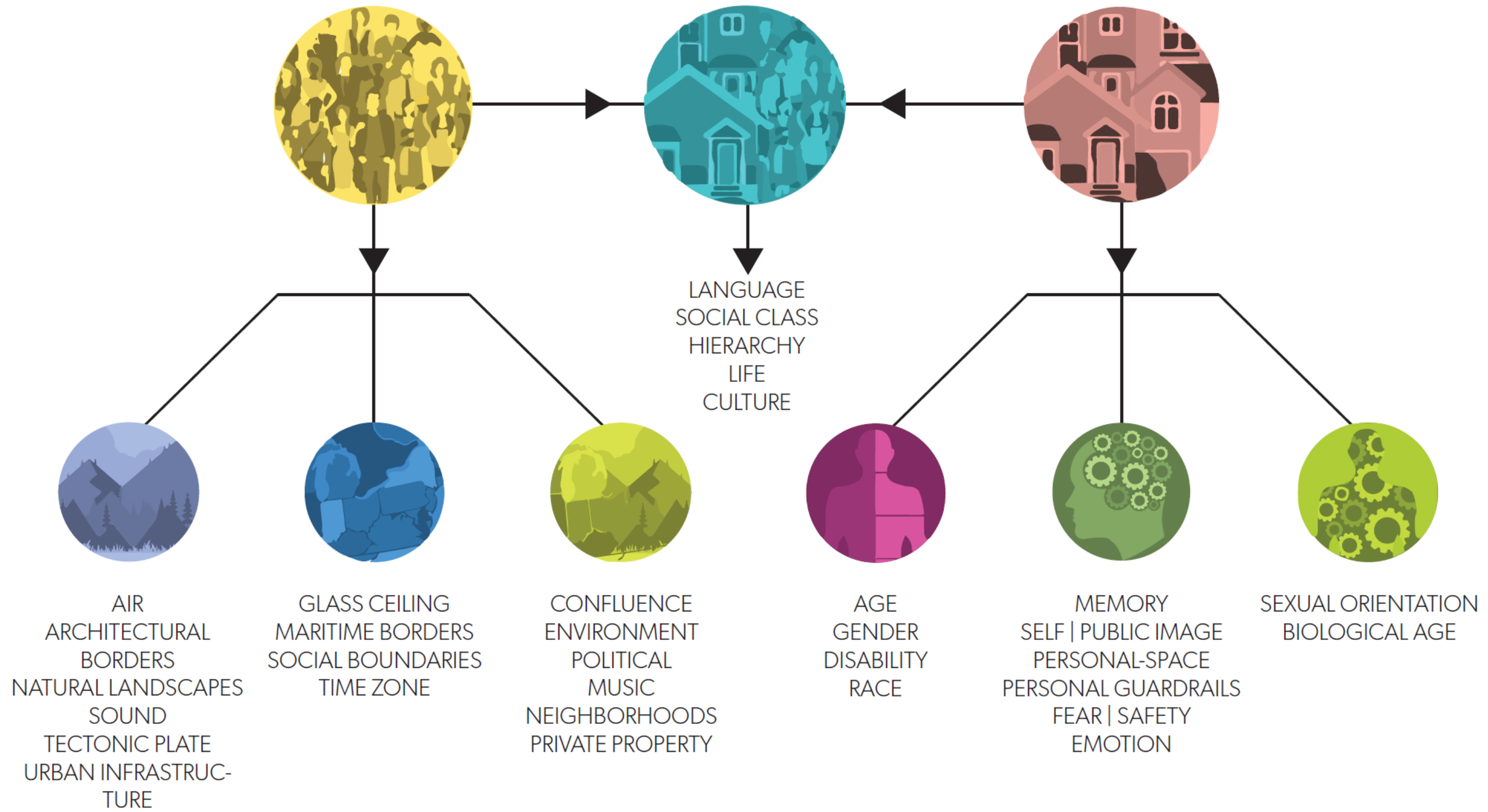



DIAGRAM 4







- 
1. How is this a border?
 2. How is it crossed?
 3. How can it be architecturally represented?

- 
1. How is this a border?
 2. How is it crossed?
 3. How can it be architecturally represented?

- 
1. How is this a border?
 2. How is it crossed?
 3. How can it be architecturally represented?



Figure 18 | Clock Work | Pixabay

28

How is this a border?

Time zones divide different parts of the globe by time.

How is it crossed?

Living organisms can travel across a time zone without knowing that they have crossed a border. These man-made borders are physically drawn on a map, result in a change of time, but are not physically seen by the human eye. The sun and the rotation of the Earth are natural phenomenon's that required humans to create these borders. The Earth rotates around its axis and around the sun that allows the sun to bring day and night across the time zone borders.

Photo Description:

Time Zones create borders around the world and represents when a society is sleeping and when they are working.

Architectural Element:

Time zones can be architecturally represented through the passing of the sun over the building to create different experiences from the morning to afternoon to the evening.

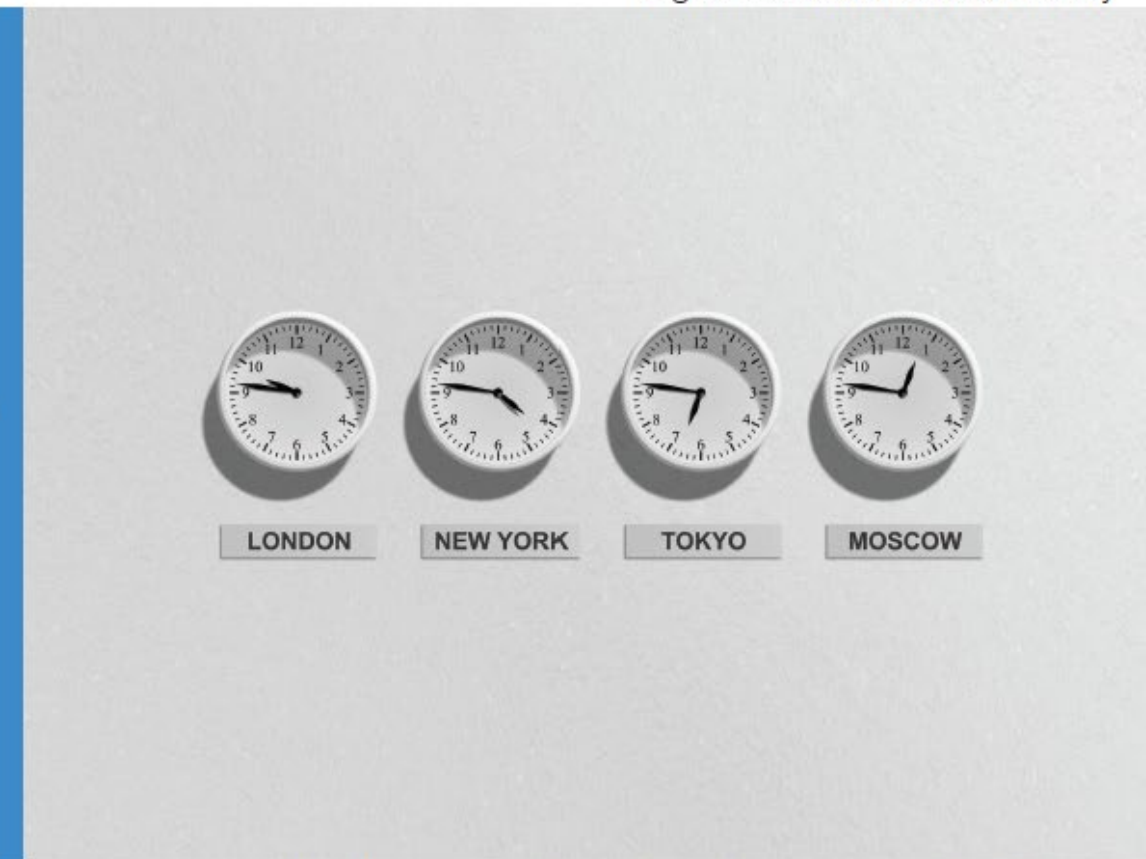

TIME ZONE

social



percelved



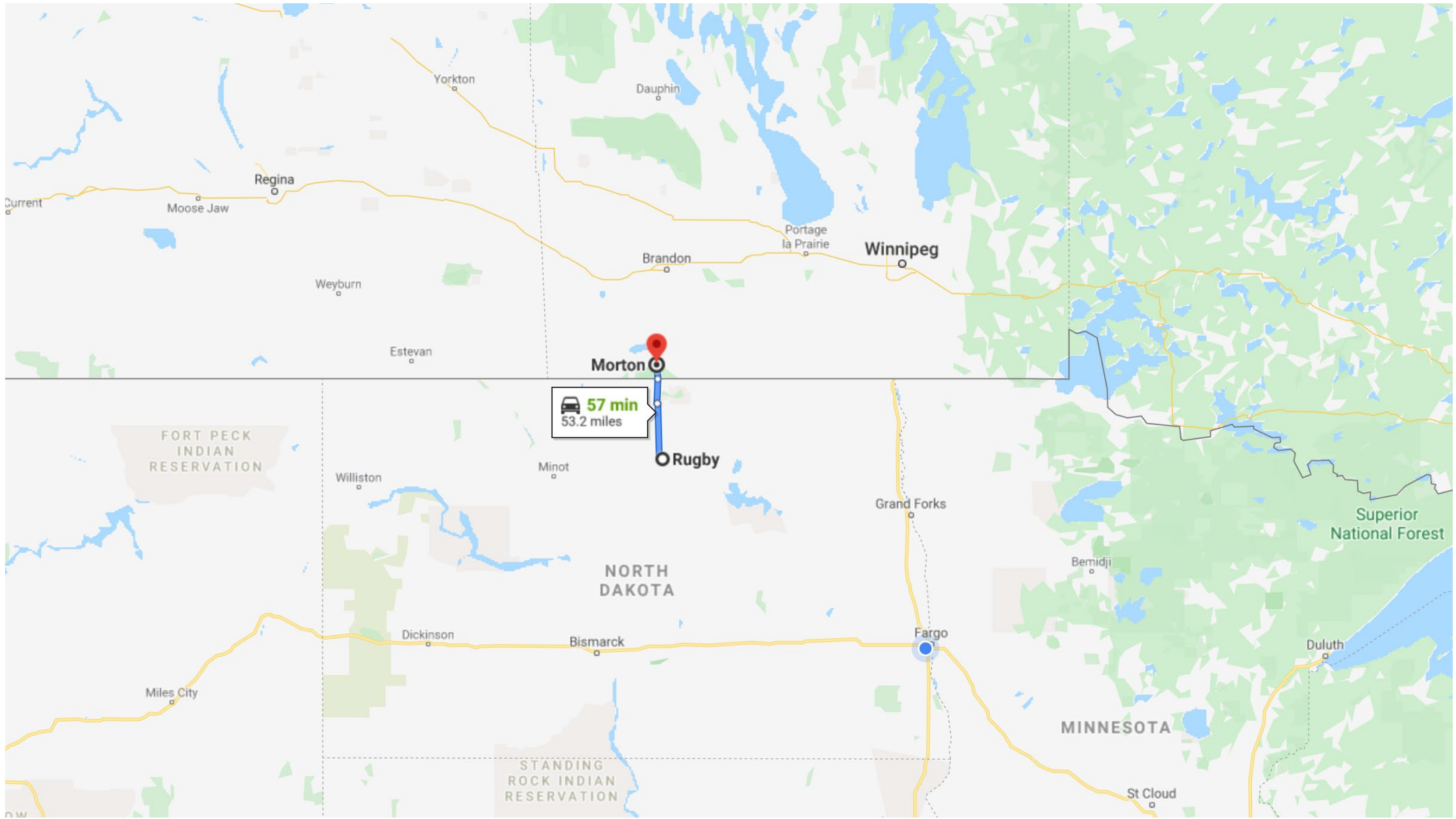



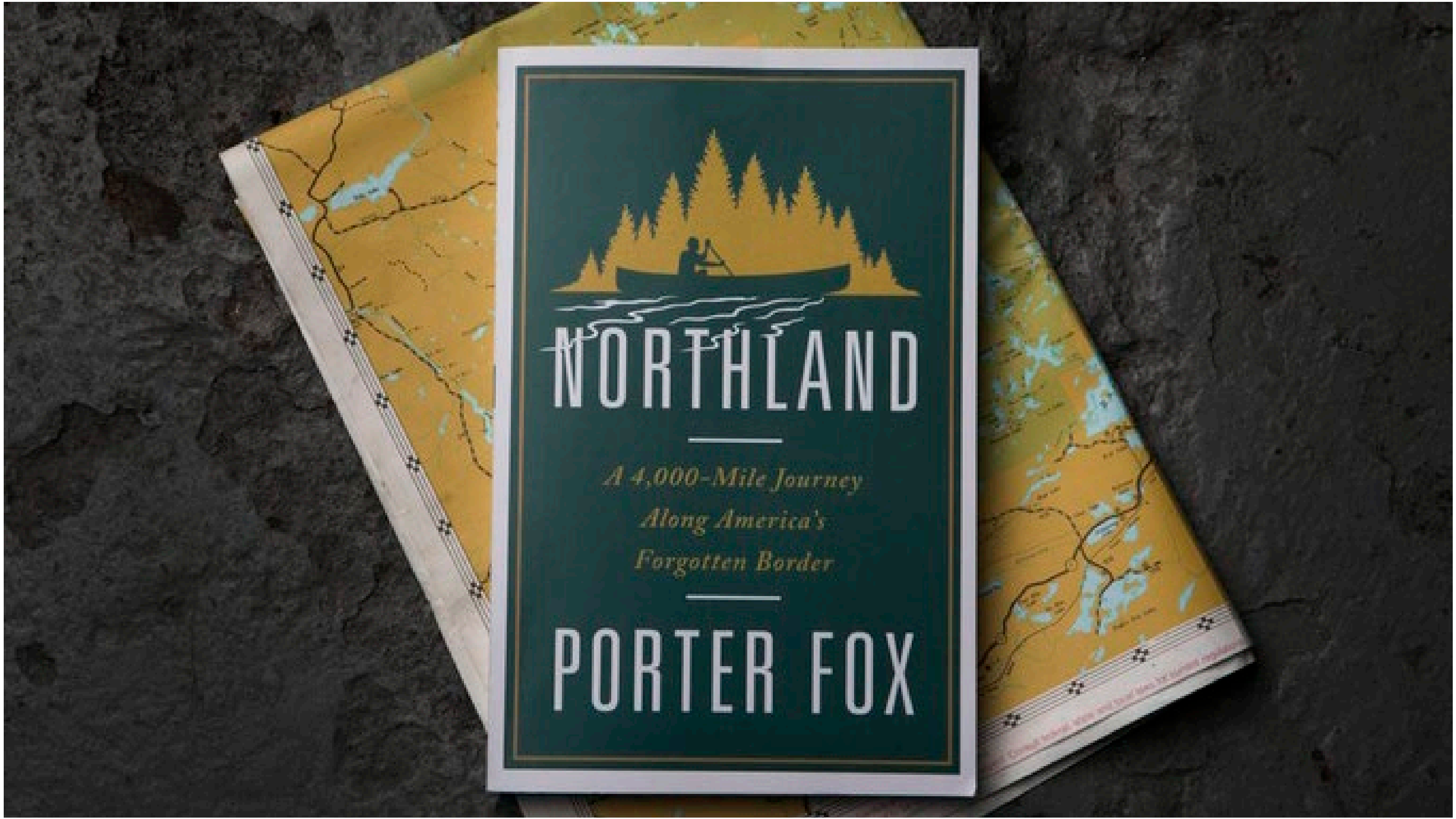

NORTHLAND

*A 4,000-Mile Journey
Along America's
Forgotten Border*

PORTER FOX

The Northland

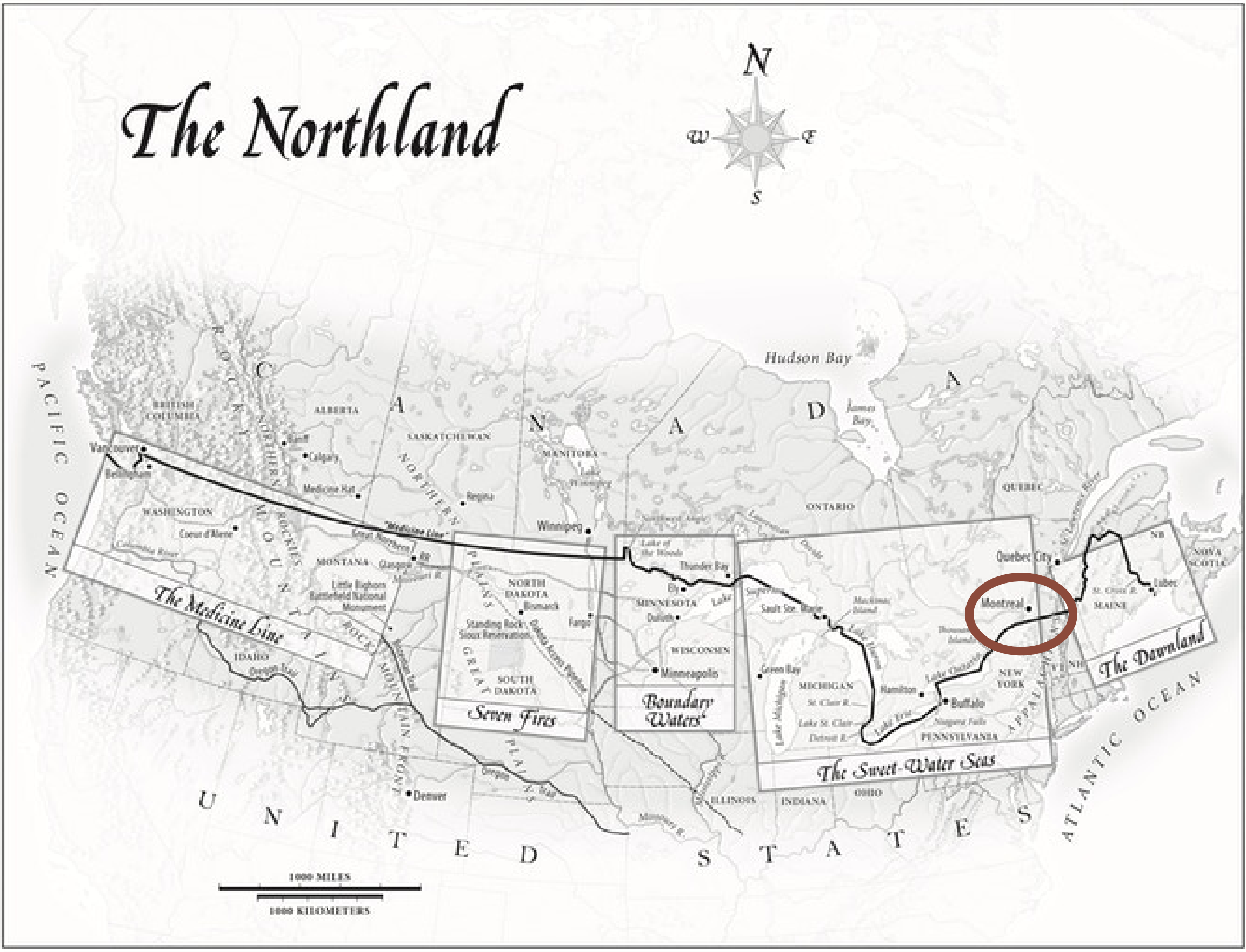

SITE CRITERIA

- ON THE US/CANADA BORDER
- NEAR A BODY OF WATER
- HISTORICAL SIGNIFICANCE
- >1 HR DRIVE FROM CITY
- NEAR BORDER CROSSING
- CENTRALIZED LOCATION



SITE CRITERIA

- ON THE US/CANADA BORDER
- NEAR A BODY OF WATER
- HISTORICAL SIGNIFICANCE
- >1 HR DRIVE FROM CITY
- NEAR BORDER CROSSING
- CENTRALIZED LOCATION



SITE CRITERIA

- ON THE US/CANADA BORDER
- NEAR A BODY OF WATER
- HISTORICAL SIGNIFICANCE
- >1 HR DRIVE FROM CITY
- NEAR BORDER CROSSING
- CENTRALIZED LOCATION



SITE CRITERIA



ON THE US/CANADA BORDER



NEAR A BODY OF WATER



HISTORICAL SIGNIFICANCE



>1 HR DRIVE FROM CITY



NEAR BORDER CROSSING



CENTRALIZED LOCATION

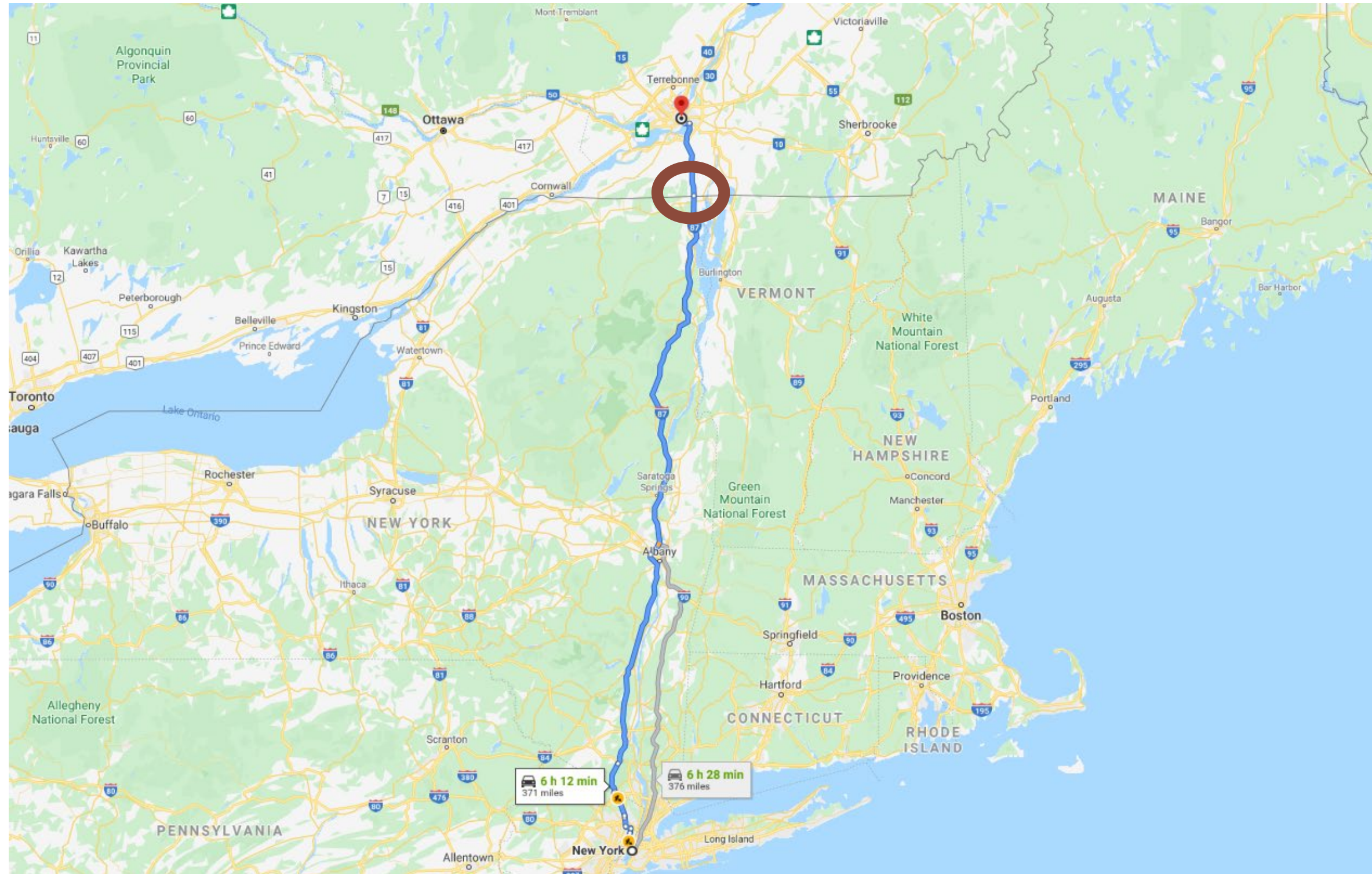

SITE CRITERIA

- ON THE US/CANADA BORDER
- NEAR A BODY OF WATER
- HISTORICAL SIGNIFICANCE
- >1 HR DRIVE FROM CITY
- NEAR BORDER CROSSING
- CENTRALIZED LOCATION

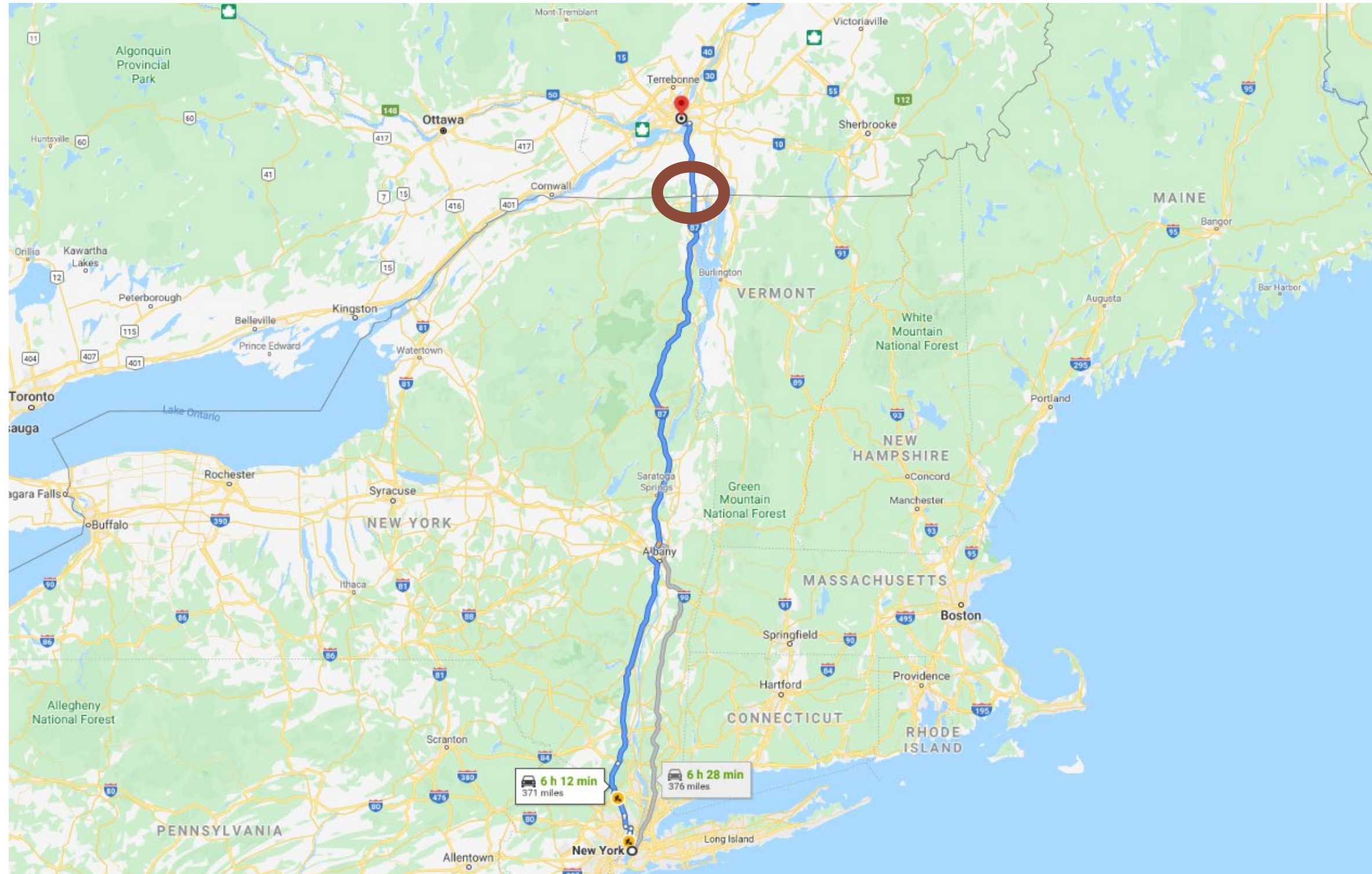

SITE CRITERIA

- ON THE US/CANADA BORDER
- NEAR A BODY OF WATER
- HISTORICAL SIGNIFICANCE
- >1 HR DRIVE FROM CITY
- NEAR BORDER CROSSING
- CENTRALIZED LOCATION

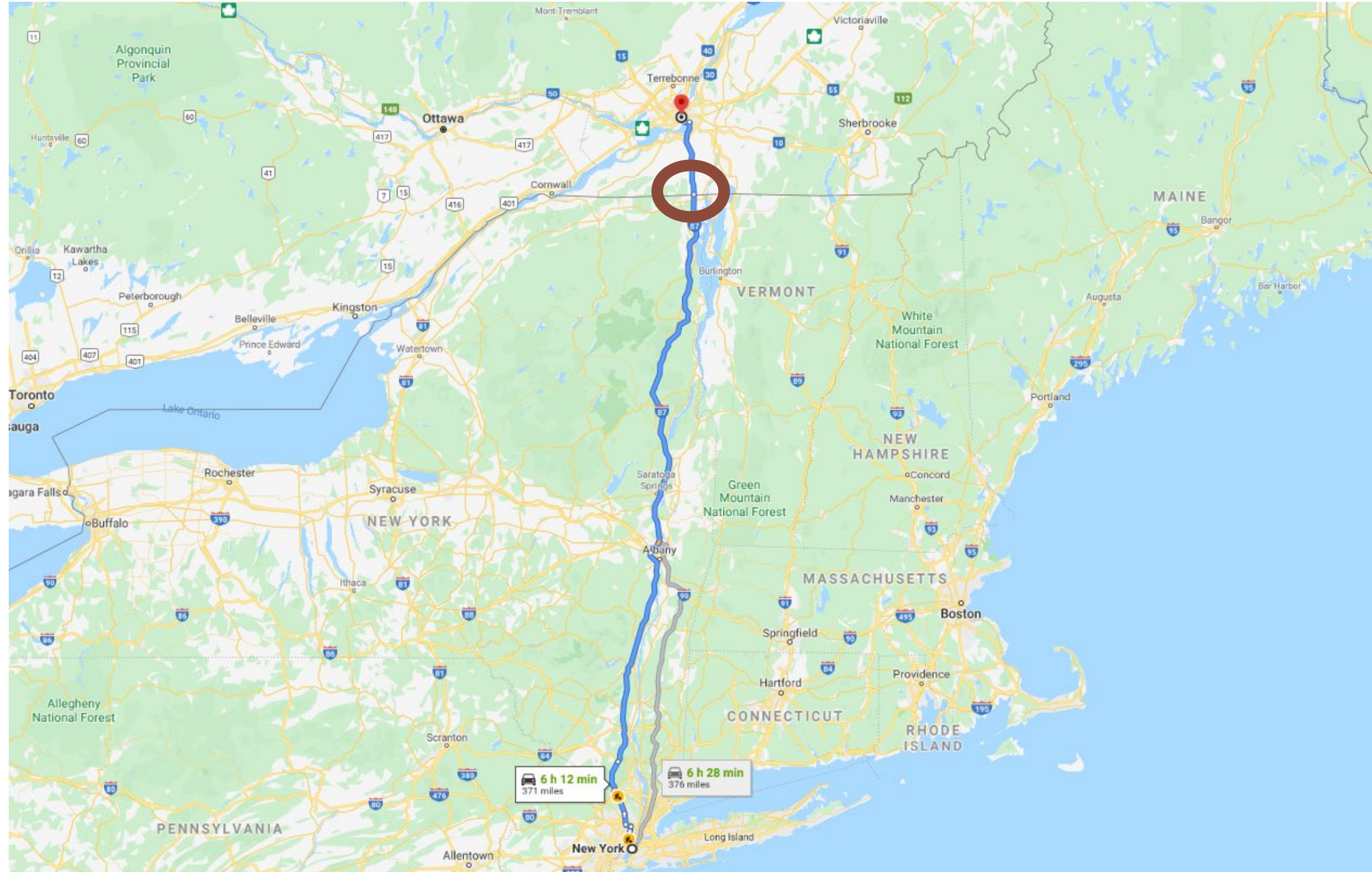

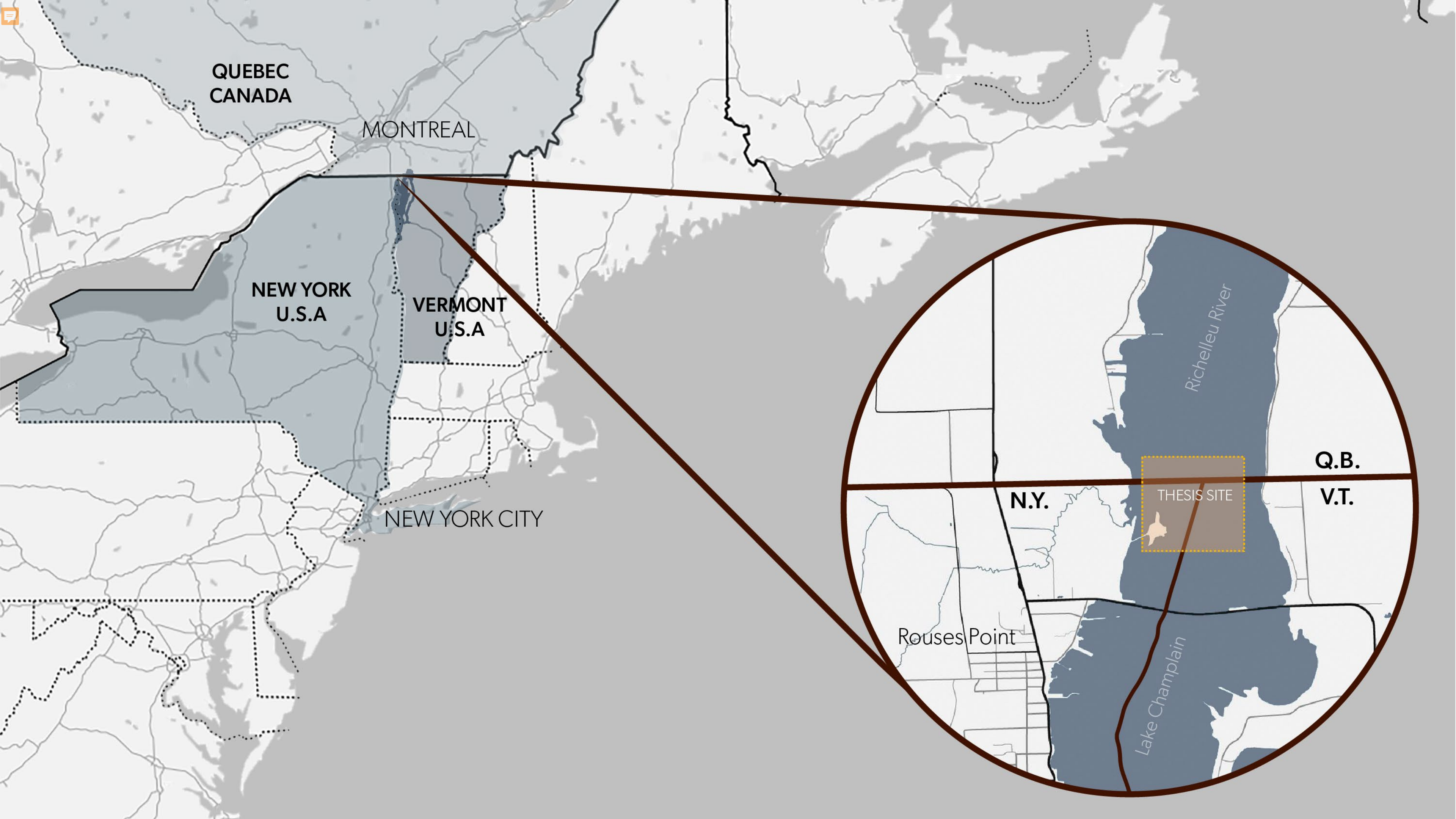

QUEBEC
CANADA

MONTREAL

NEW YORK
U.S.A

VERMONT
U.S.A

NEW YORK CITY

N.Y.

THESIS SITE

Q.B.

V.T.

Rouses Point

Lake Champlain

Richelleu River

YOU ARE NOW ENTERING A NEIGHBORHOOD WATCH ZONE

Welcome
VILLAGE OF
ROUSES POINT
Founded 1783
The Northern Gateway



WELCOME TO
NEW YORK
The Empire State



FORT MONTGOMERY
NAMED FOR AMER. GEN. RICHARD MONTGOMERY, REV. WAR HERO KILLED AT QUEBEC 1775. THIS FORT BEGUN 1844. ARMAMENTS REMOVED 1900.

BUCKLE UP!
NEW YORK LAW
SEAT BELT USE
REQUIRED

STATE ROAD
USE OF HAND HELD
DEVICE BY DRIVER
PROHIBITED

CALVIN
CASE



Fort Montgomery: Why Is It Here? / Le Fort Montgomery: Pourquoi est-il situé en ce lieu?

Champlain Canal

Quebec

New York

Vermont

Champlain Canal

Before the construction of U.S. Fort Montgomery, the area was a marshy plain. The site was chosen for its strategic location on the Champlain Canal, which provided a direct route between the Hudson River and Lake Champlain. The fort was built on a small island in the middle of the canal, making it difficult to access from either side.

Following the construction of the Champlain Canal in 1820, and a subsequent treaty in 1826, the fort was abandoned. The site was eventually purchased by the U.S. Army in 1892, and the fort was reconstructed as a historical site. Today, the fort is a popular destination for visitors to the Champlain Canal and Lake Champlain.

Completed long after hostilities with Great Britain had ended, Fort Montgomery was never fully equipped and its armaments were mostly obsolete. In 1838, the property was donated to the State of New York. In 1946, it was transferred to the National Park Service. The fort was reconstructed by the Champlain Canal Authority, Vermont, and the State of New York. The fort was dedicated in 1982.

Fort Montgomery—designed as a deterrent to Britain—never saw battle action.

Fort Montgomery is located in the Champlain Canal, between New York and Vermont.

Fort Montgomery

Fort Montgomery

Fort Montgomery

Fort Montgomery



A
SURVEY
OF
LAKE CHAMPLAIN,
including
LAKE GEORGE, CROWN POINT AND S.^T JOHN.

Surveyed by Order of
HIS EXCELLENCY MAJOR-GENERAL S.^R JEFFERY AMHERST,
Knight of the most Hon^{ble} Order of the Bath,
Commander in Chief of His Majesty's Forces in North America,
(now LORD AMHERST)

BY
WILLIAM BRASSIER, DRAUGHTSMAN.

1762.

British Miles.

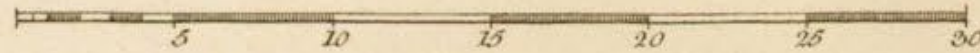

Places whose Latitude has been Observed.

Crown Point 43^d 50^m 7^s }
More Point 45 - 0 - 0. } *Vide Topog. Desc. p. 3.*

OBSERVATIONS.

Lake Champlain to which the Dutch formerly gave the name of Corlaer, is called by the Indians Caniad eri - Guarunte signifying The Mouth or Door of the Country. It lies in a Deep Narrow Chasm of the Land bounded up to the



Explanation of the Engagement,
between Valcour Island and the Western Shore, October the 11th 1776.

British Fleet under Genl. Carleton.

- A. American Fleet consisting of 15 Vessels, under Benedict Arnold.
- B. Twenty one Gun Boats.
- C. Schooner Carleton, 12 Six Pounders.
- D. Ship Intrepid, 18 Twelve Pounders.
- E. Anchorage of the Fleet during the Night, to Cut off the Rebels Retreat.
- F. Raouleau Thunder, 6 Twenty Four, 6 Twelve Pounders.
- G. Gondola Loyol Covert, 7 Nine Pounders.
- H. Schooner Maria, 11 Six Pounders, with General Carleton on Board.
- I. Where the Rebel Schooner Royal Savage, of 8 Six Pounders, and 4 Four Pounders, was Burnt.

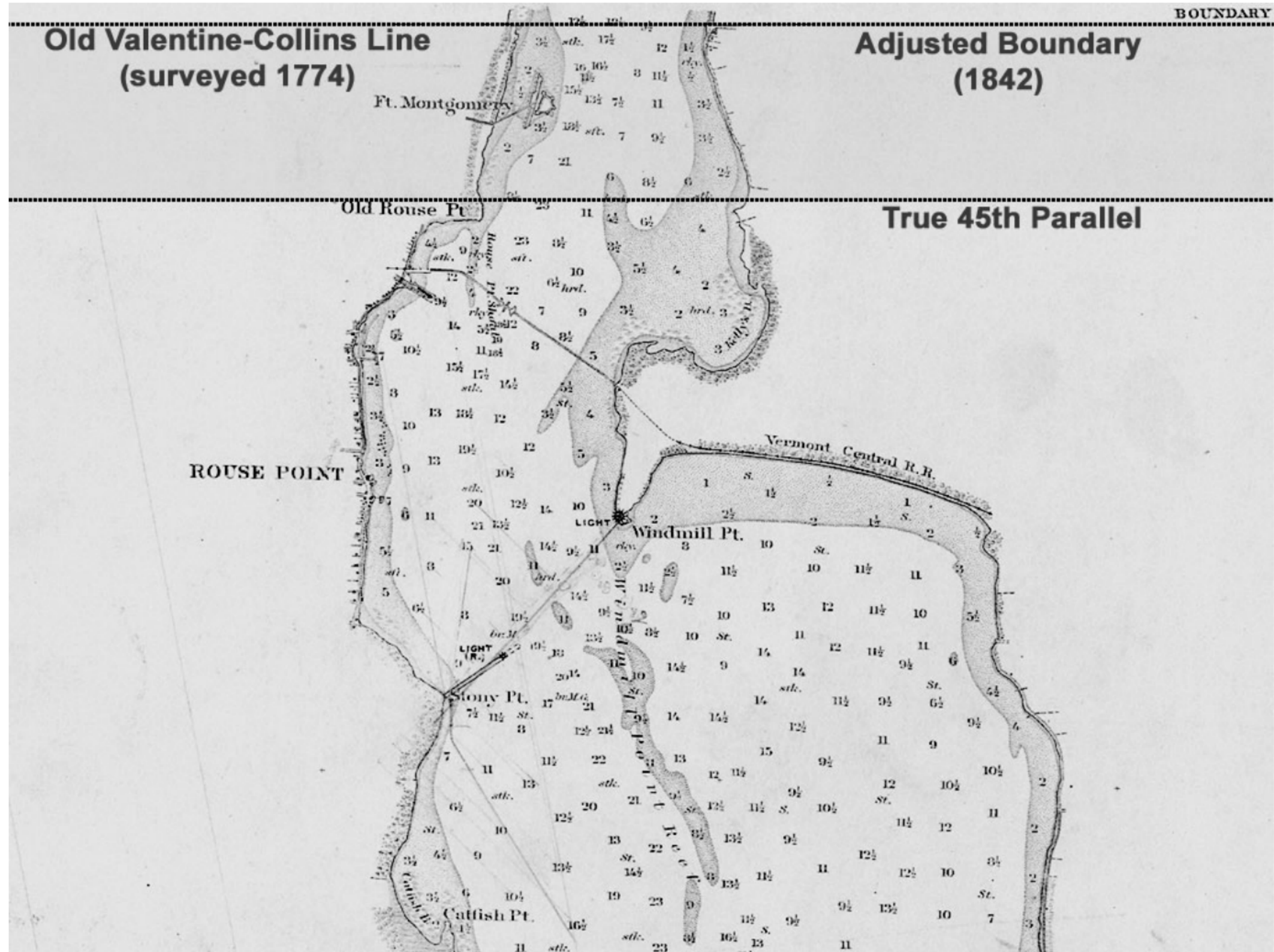

This map, after a US Coast and Geodetic survey map of 1879, shows the adjusted border and the actual line of 45° as corrected in 1818.

Drawer 7.
Sheet 14.

ROUSE'S POINT

Engineer Department
Washington, April 9th 1844.

This plan of a fort for Rouse's Point at the outlet of Lake Champlain has been projected by the Board of Engineers after careful surveys, examinations of the ground, & study: its details having been adjusted under instructions of the Board by Capt. Henry Dawkins a member thereof. With the exception of details which I desire to see changed or modified, & which can be arranged with the constructing officer, and with the further exception of certain features in the cover face which can be altered without any loss of strength & efficiency & with a material diminution of cost, with these and such other exceptions as a more particular study of the project of the work shall show to be proper, this project is recommended for the approval of the Secretary of War.

H. D. [Signature]
[Signature]

Plan Sections and Elevations of FORT ROUSE'S POINT

projected for the defence of
the outlet of
Lake Champlain

Drawn by the designer

By the [Signature] [Signature]

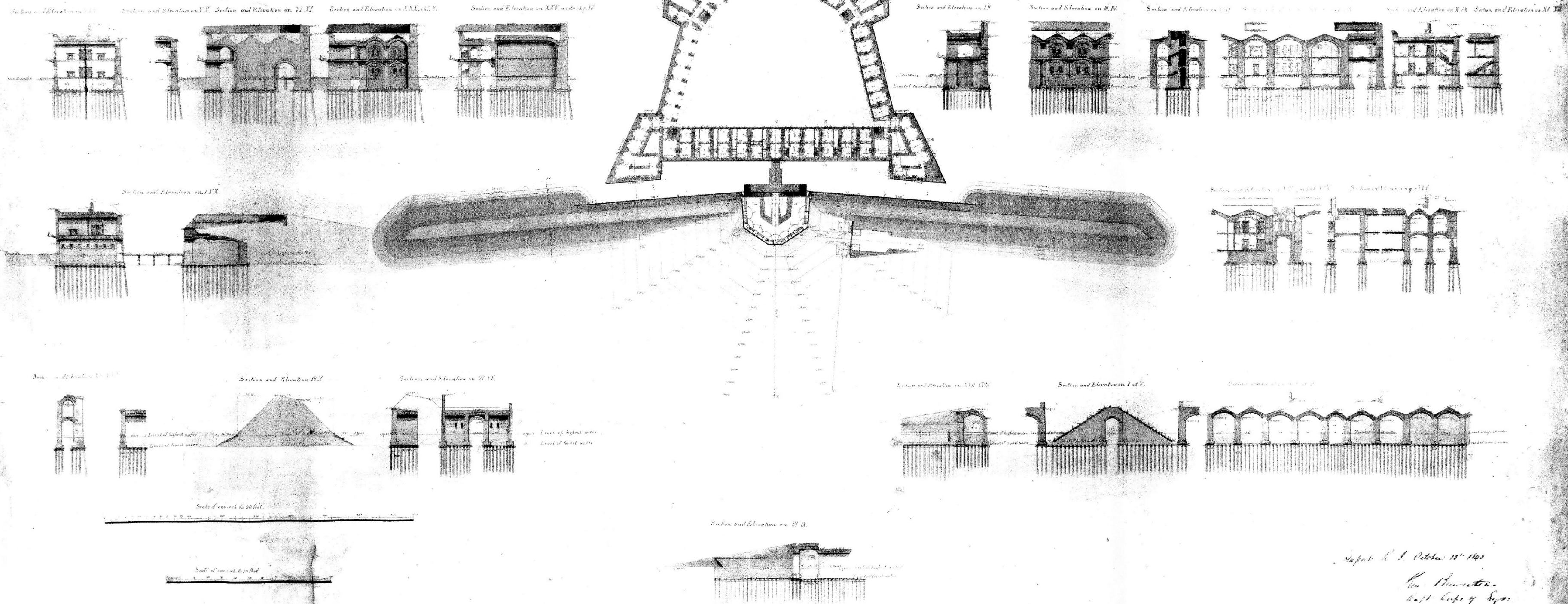

Major G. S. October 15th 1843
[Signature]
Capt. [Signature]
[Signature]

Fort Montgomery, Rouses Point, N. Y.

72302

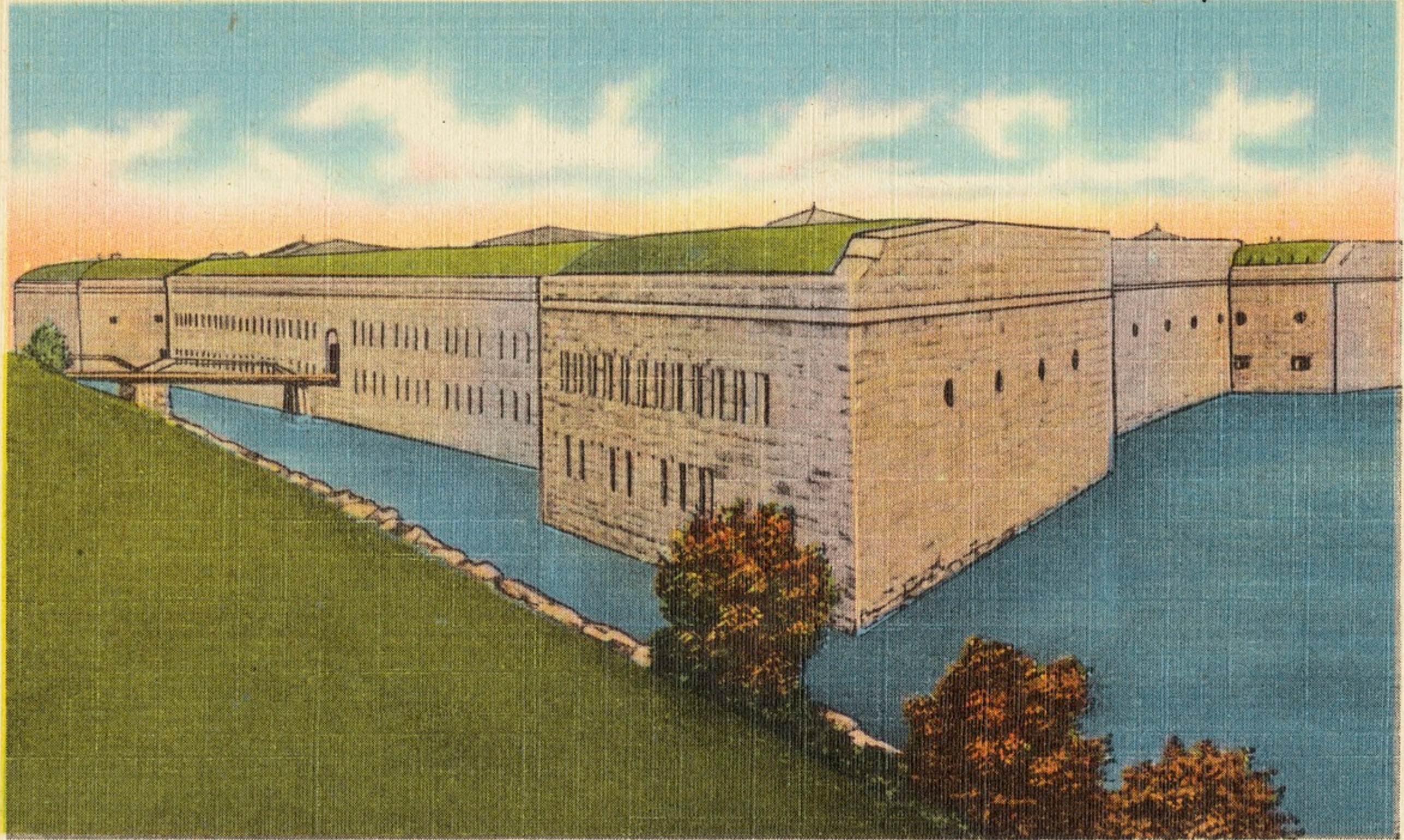

72302

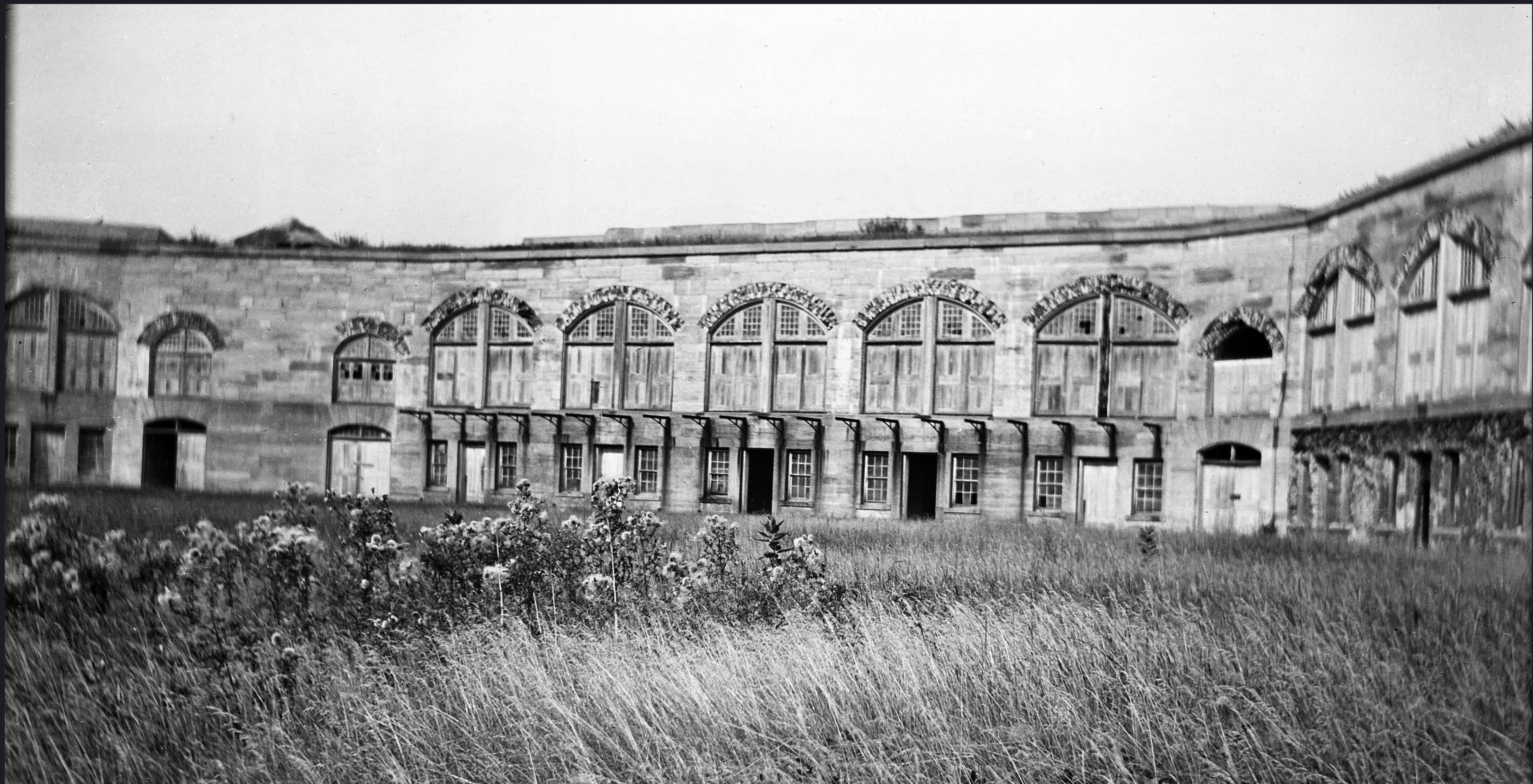



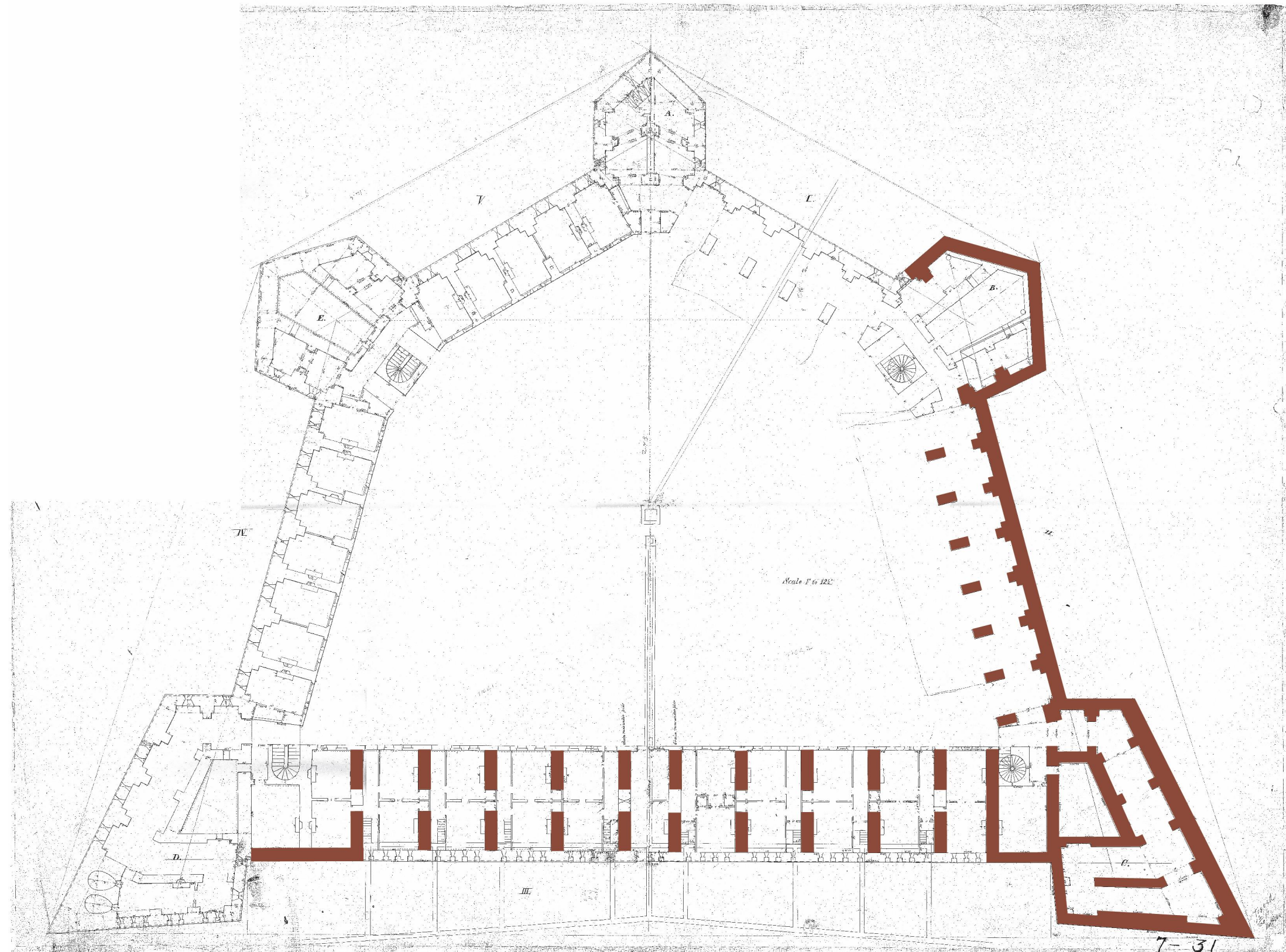

9. Sheet 31 added 1903

7-31





FALLING
OUT
KOLEM
MARRON

O'CONNOR
WILHELMSCHE
COHEN
JENNINGS

GMA
HAB
VCE

YO
CAN
D CAMPBELL
MINGM

Sw
R
C
Go
w

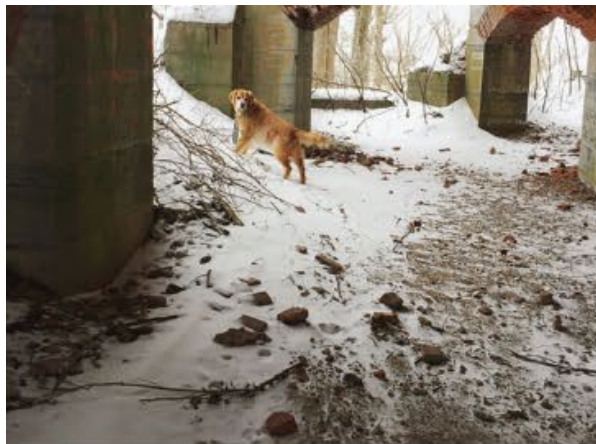

73 likes
olivierlavallee Fort discovery 📷

tcnole1 · Follow
Fort Montgomery (Lake Champlain)



35 likes
tcnole1 The ruins of Fort Montgomery in upstate NY. #fortmontgomery #dronephotography #dronestagram #drones #djimavic #adironacks #adk #adklife #ilovenewyork #upstateny #mynbc5

upnorthoutdoors_23 · Follow
Fort Montgomery (Lake Champlain)

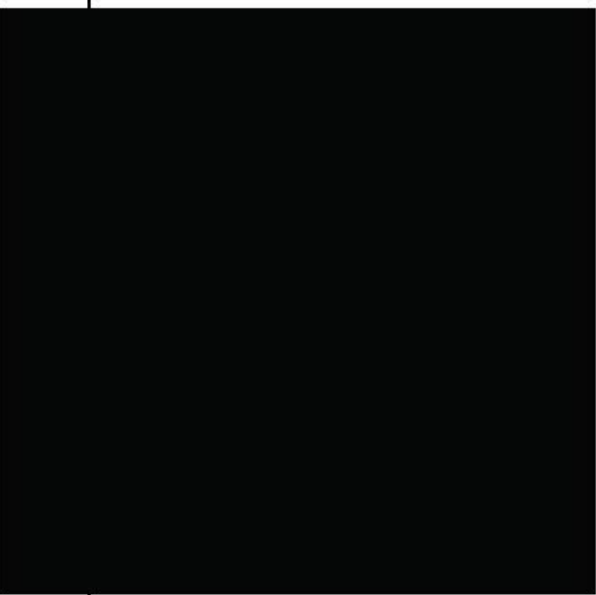
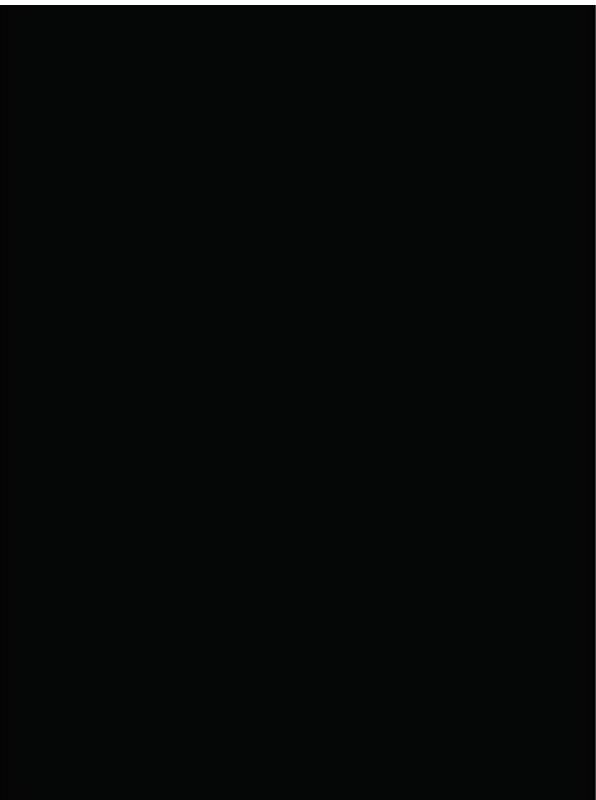

65 likes
chelsaeroo Ten years today with this bright spirit of a being! Here's to the next ten filled with adventure, love and good health! 🥰 @iselindesigner

northamerican · Follow
Fort Montgomery (Lake Champlain)



12 likes

jimphotos · Follow
Fort Montgomery (Lake Champlain)

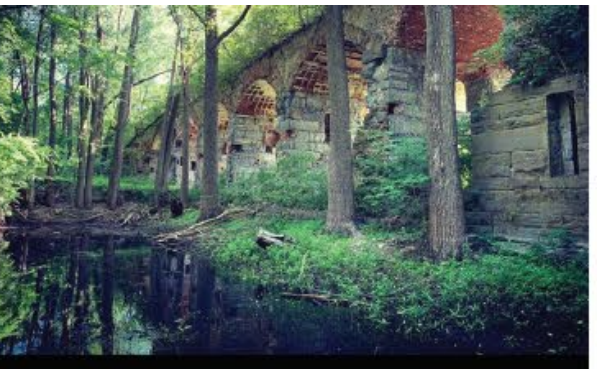

29 likes
metallidan Very cool paddle today from #Vermont to New York at Rouses Point to an #abandoned (and for sale) Fort Montgomery. #kayak #fortmontgomery #fortblunder #americanhistory #canada #itsabandoned

shanna_white74 · Follow
Fort Montgomery (Lake Champlain)



13 likes
shanna_white74 100k around Lake Champlain. Two states, bridge, causeway and a ferry. Beautiful September day.
bdpellow damn should packed the fishing rod in the jersey

bayrippers · Follow
Fort Montgomery (Lake Champlain)

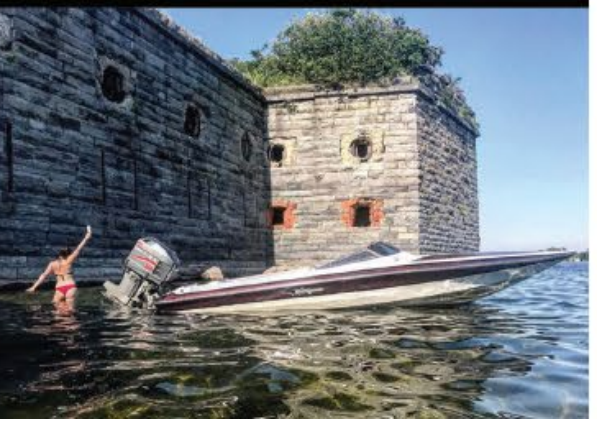

88 likes
alexbitsakis History class was fun this weekend. #uncharted

wade.strelac · Follow
Fort Montgomery (Lake Champlain)



203 likes
wade.strelac People say not to fish "history" but this looked too good to pass up!

danemartin2788 · Follow
Fort Montgomery (Lake Champlain)



36 likes
danemartin2788 Exploring Ft. Montgomery yesterday #lakechamplain #canada #newyork #nikonusa #nikon #candid #burton #photography #photo #instagreat #pics #instagood #adventure #fun #explore #gooutside

dog_mctease · Follow
Fort Montgomery (Lake Champlain)



24 likes
tcnole1 Winter/Summer aerial photographs of Fort Montgomery. I miss summer lol... #fortmontgomery #dronephotography #djmavic #winter/summer #Lake Champlain #adironacks #adk #adklife #upstateny #rousespoint

kaydubxo · Follow
Fort Montgomery (Lake Champlain)



51 likes
kaydubxo Such an unreal place 🤩 love our adventures together @fosta25

djtrickypat · Follow
Fort Montgomery (Lake Champlain)





446 likes
emmahauck The one and only @wfletcher24 🥰

laurensivophotography · Follow
Lake Champlain



38 likes

laurensivophotography When your friends have a house on a gorgeous beach, what else is there to do but get married there?!? Hair/Makeup: @daniellepiercebeauty Flowers: @infullbloomvt

alex_twatts · Follow
Lake Champlain

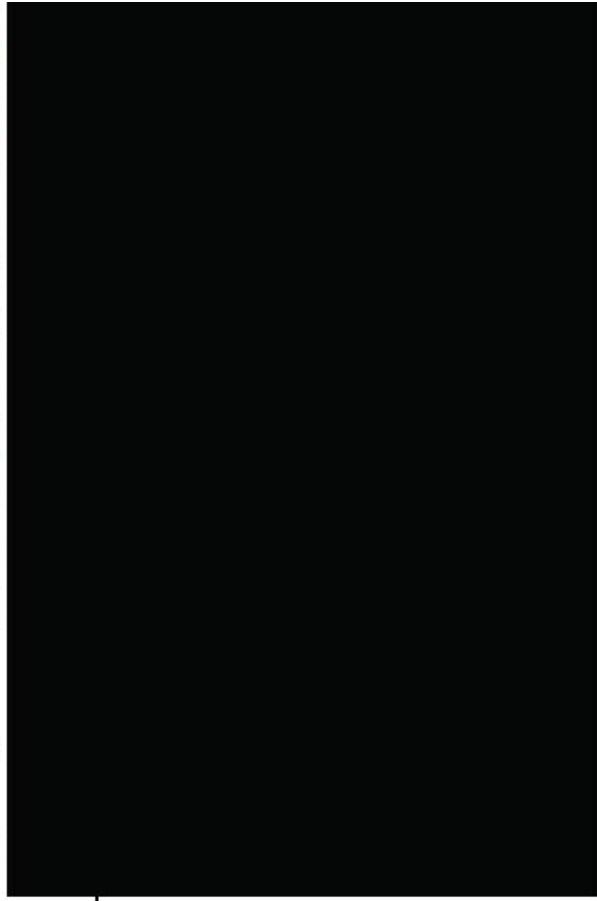

94 likes
brendanclementmusic Vermont being all like, "you know you wanna live here..." 🍷🍷🍷
View all 5 comments
david_aloisi 🍷🍷🍷🍷🍷🍷🍷🍷
newfallshats · Commented
President

maximemacgregor · Follow
Lake Champlain



45 likes
maximemacgregor Soaking in the last weeks as a family of three 🍷🍷🍷
mais pour nous faire patienter on a un gros bébé qui adore se faire cajoler 🍷
claire_goldman · Follow
Lake Champlain



378 likes
maddie_dlt champagne floats my boat. sorry, champlain

scottmartinchallenge · Follow
Lake Champlain



24,277 views
scottmartinchallenge Champlain holds a special place in my heart..there is a lot on the line this week. All I can do is Pray Hard/Fish Hard..Day 1 Starts in the morning. .

sarajacobi_ · Follow
Lake Champlain

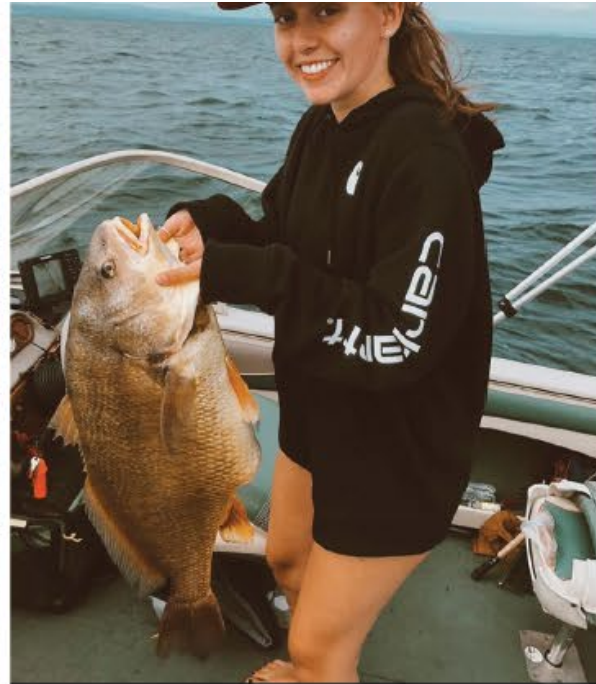

169 likes

lilymargaret5 · Follow
Lake Champlain



211 likes
lilymargaret5 brb skating to NY

alexandresansoucy · Follow
Lake Champlain



323 likes
annamh_1103 walking on water

carl_jocumsen · Follow
Lake Champlain



9,092 views
carl_jocumsen The greatest two fish catches of my fishing career 🍷 Back to back 5-8lb and Big Bass of the Tournament 6-4lb on Lake Champlain in the final minutes of the day. From 70th to a top 12!! #AllHeart #NoQuit #FearMyHeart

ava.debruin · Follow
Lake Champlain





Entering
Vermont



















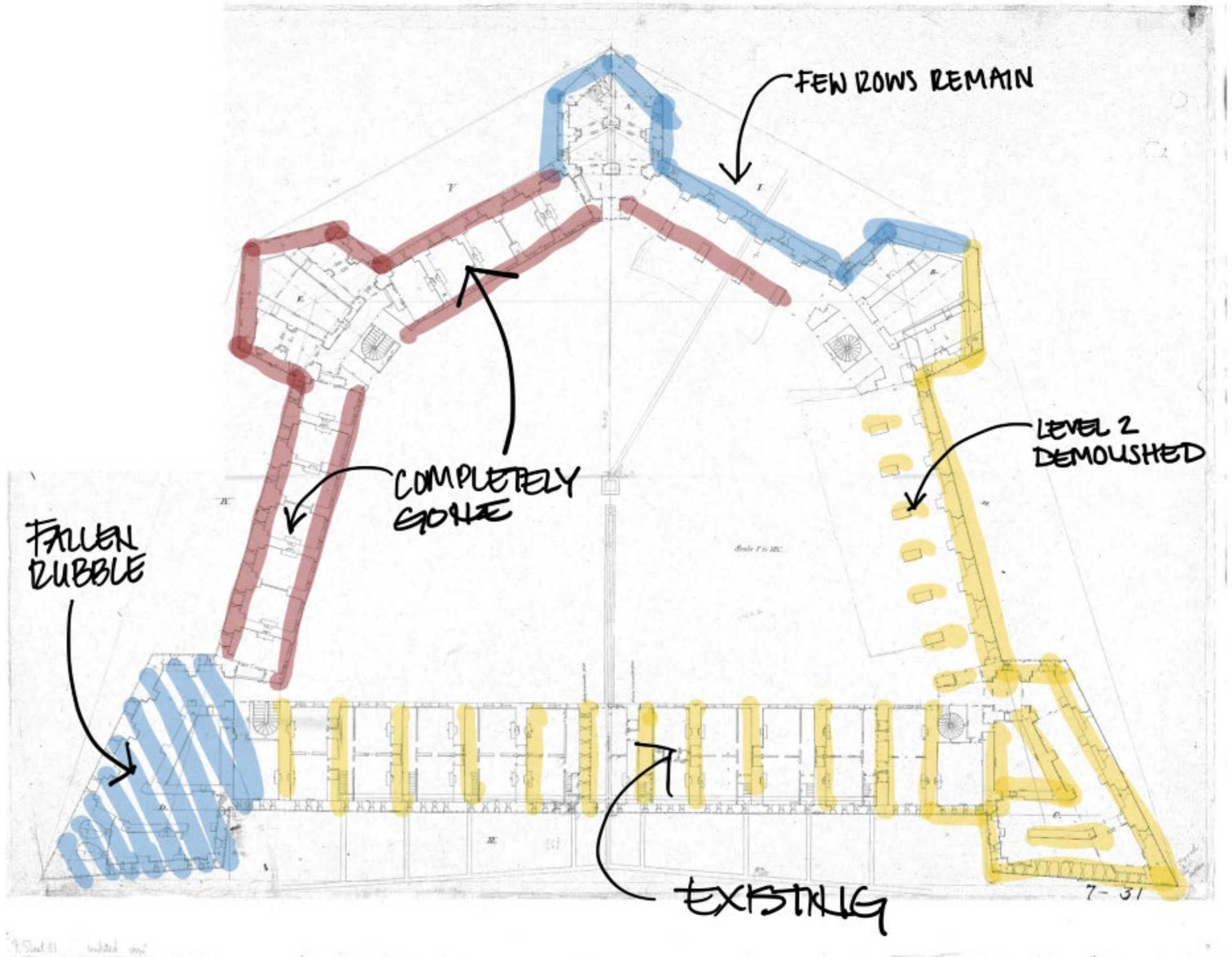

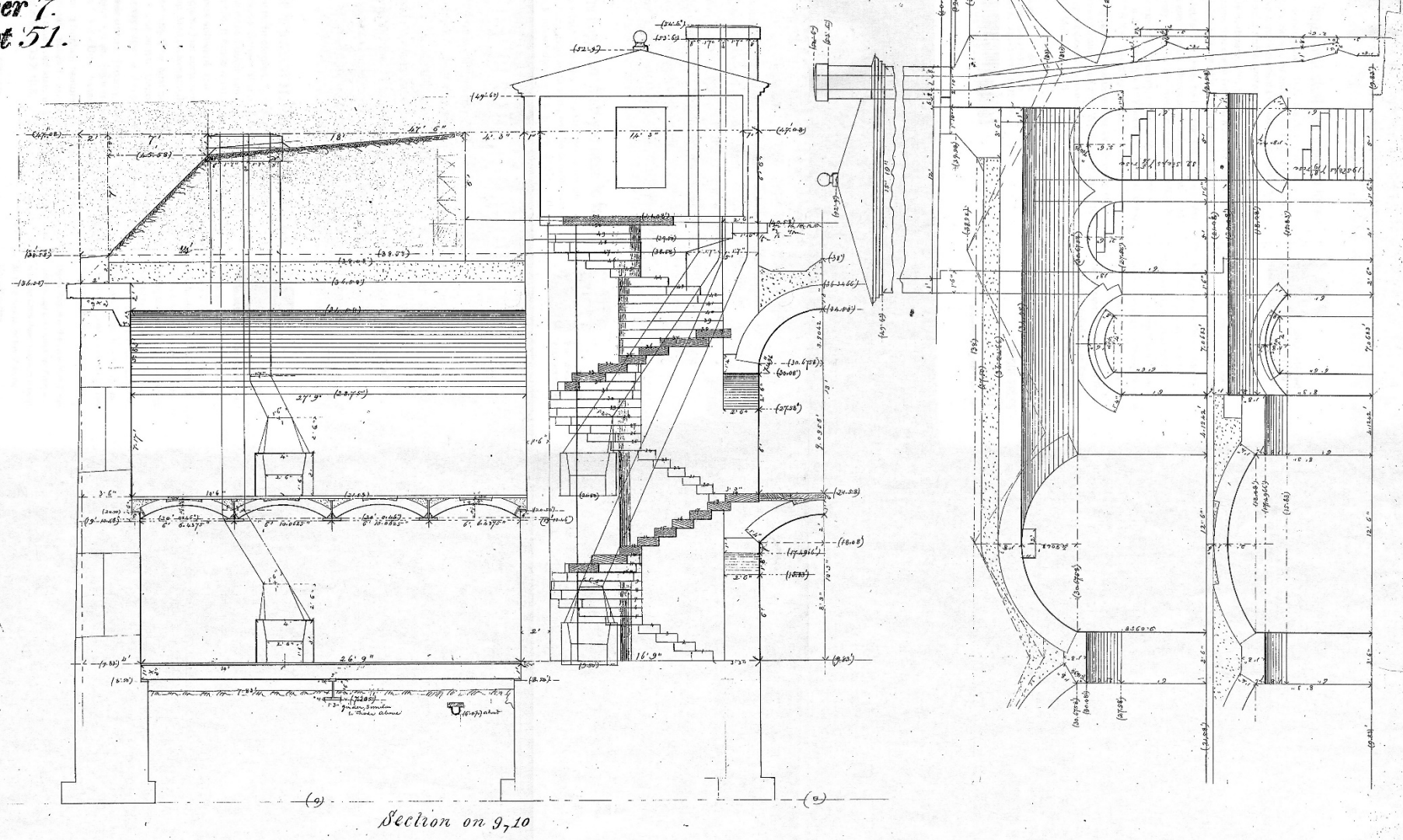

Section on 9, 10

Fort Montgomery

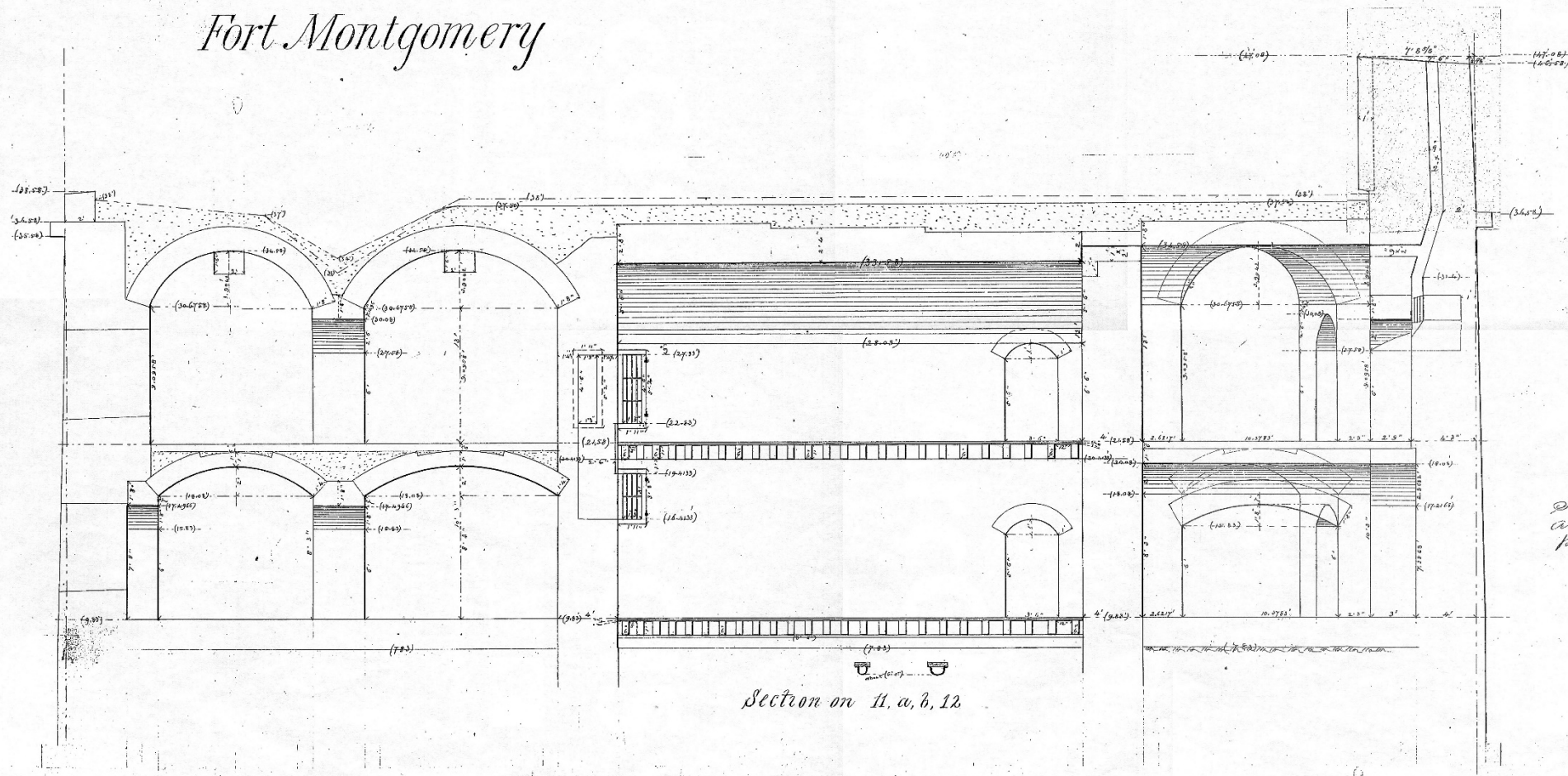

Section on 11, a, b, 12

Section on 15, 16

LEVELS OF FORT MONTGOMERY

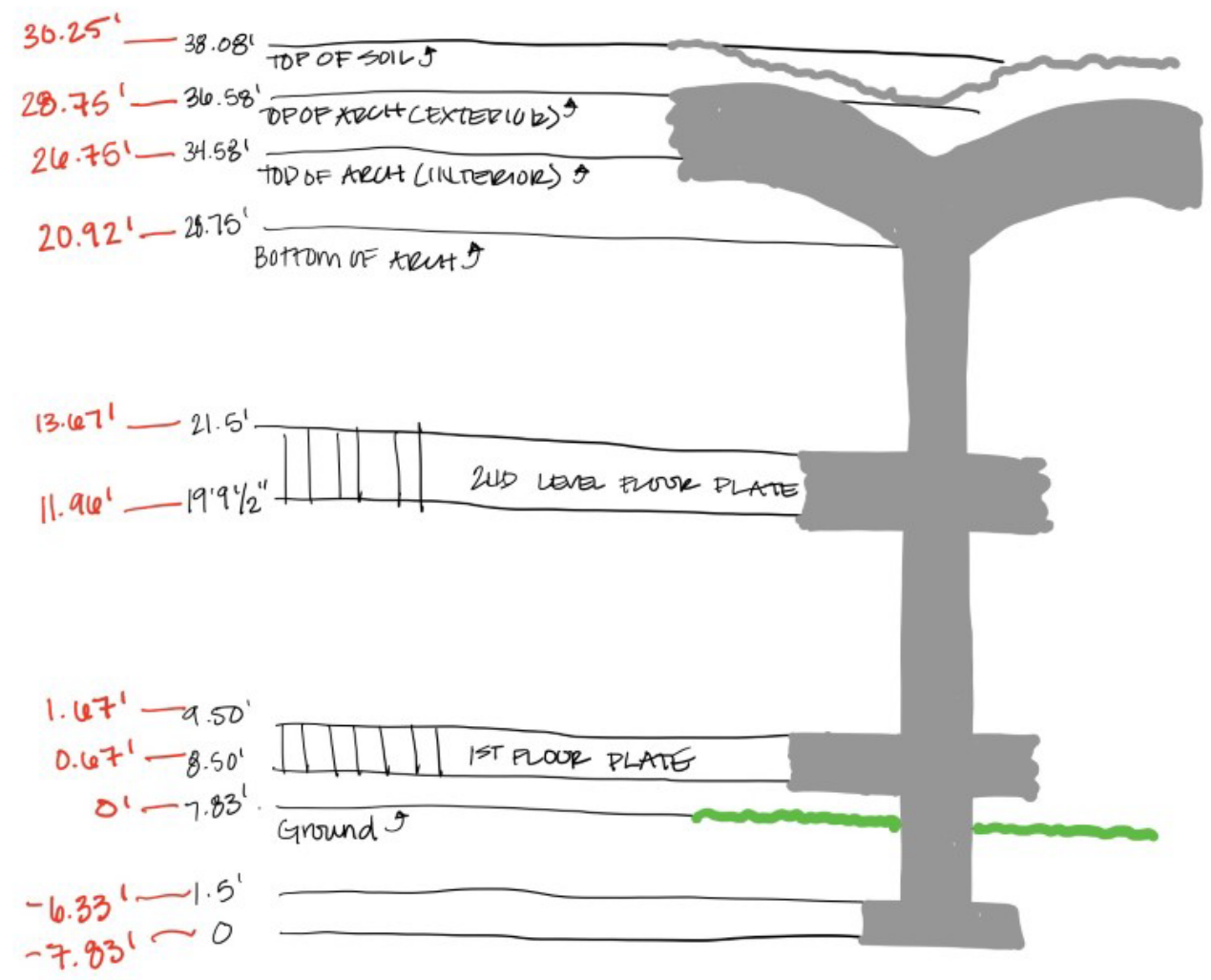

Engr Dept. San. Dept.
Shut to exhibit to be copied
and returned as soon as
possible

Engineer Dept.
Jan 12 1858
Received back this day
Returned with Lieut. Blair's
letter of Jan 5 1858 (B/S 571)
rec. Jan 8/58

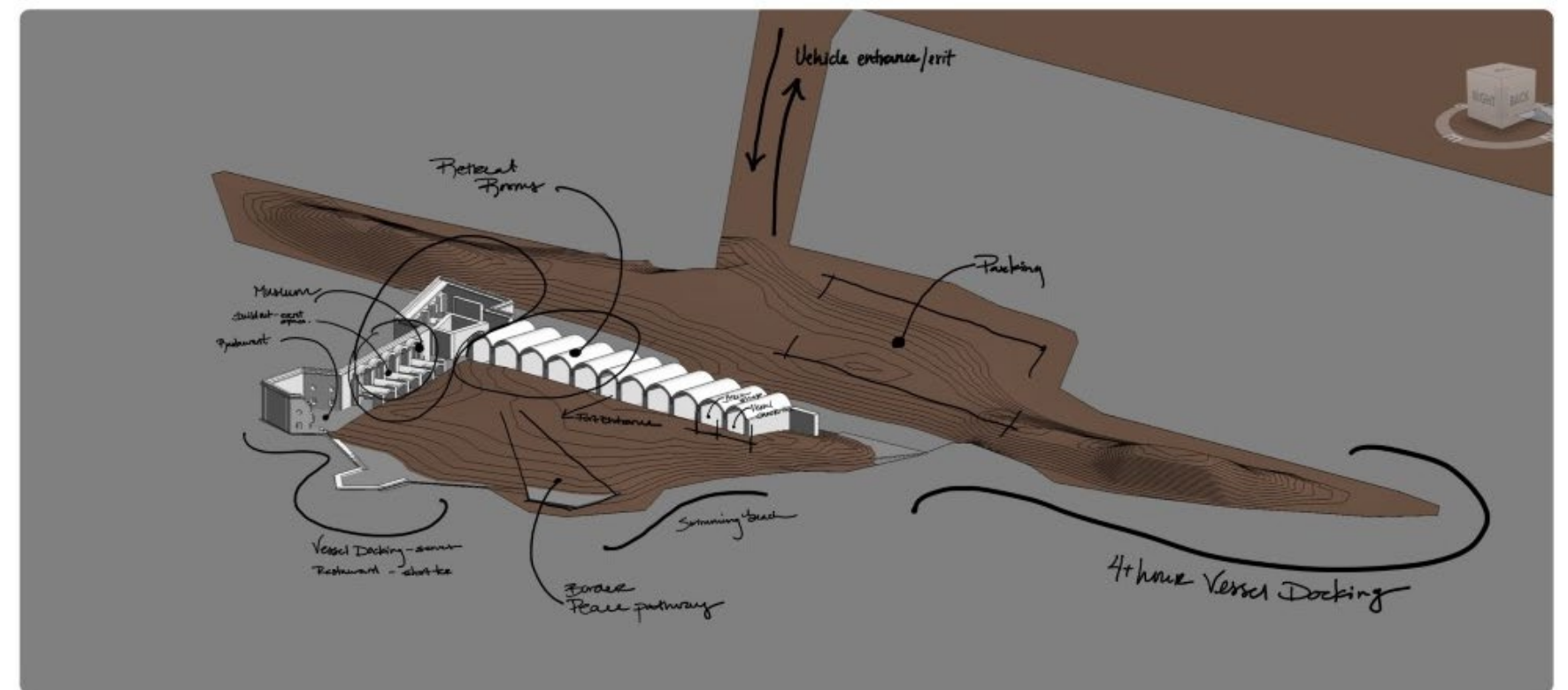
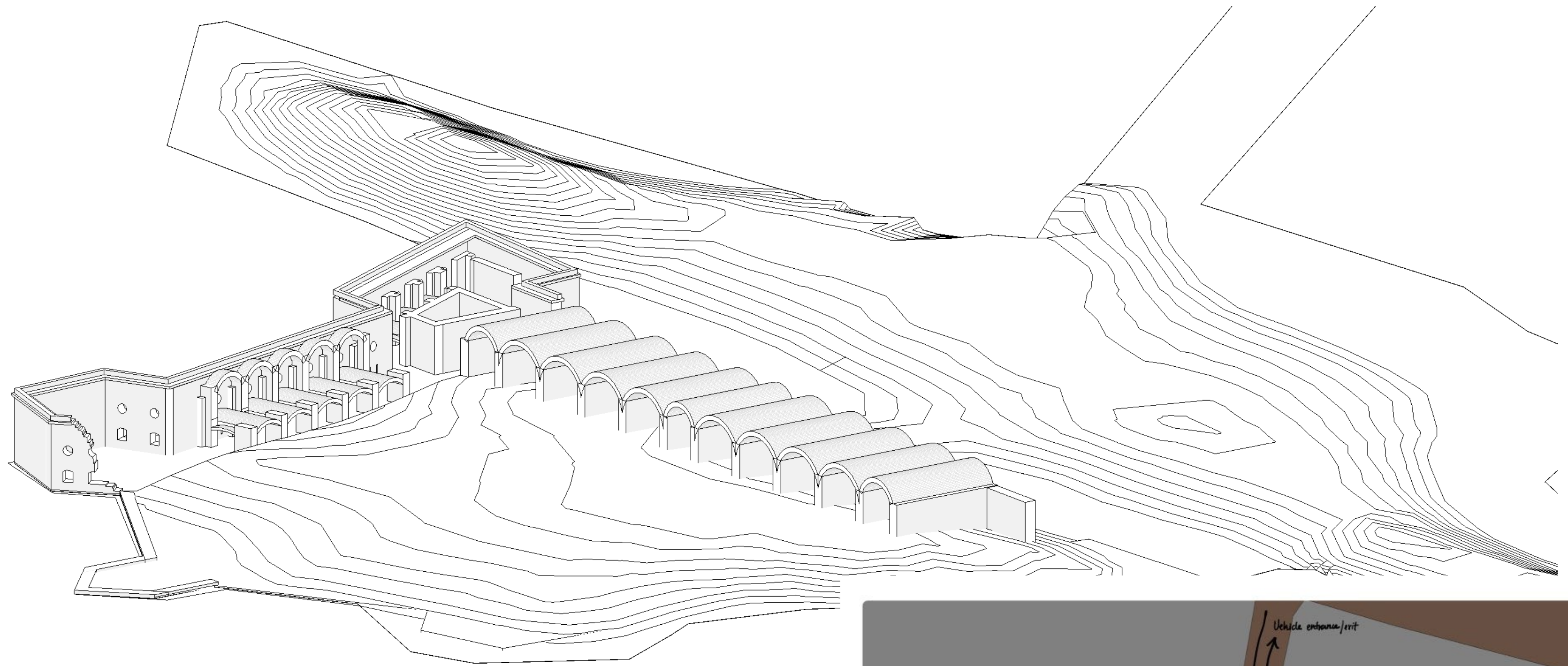

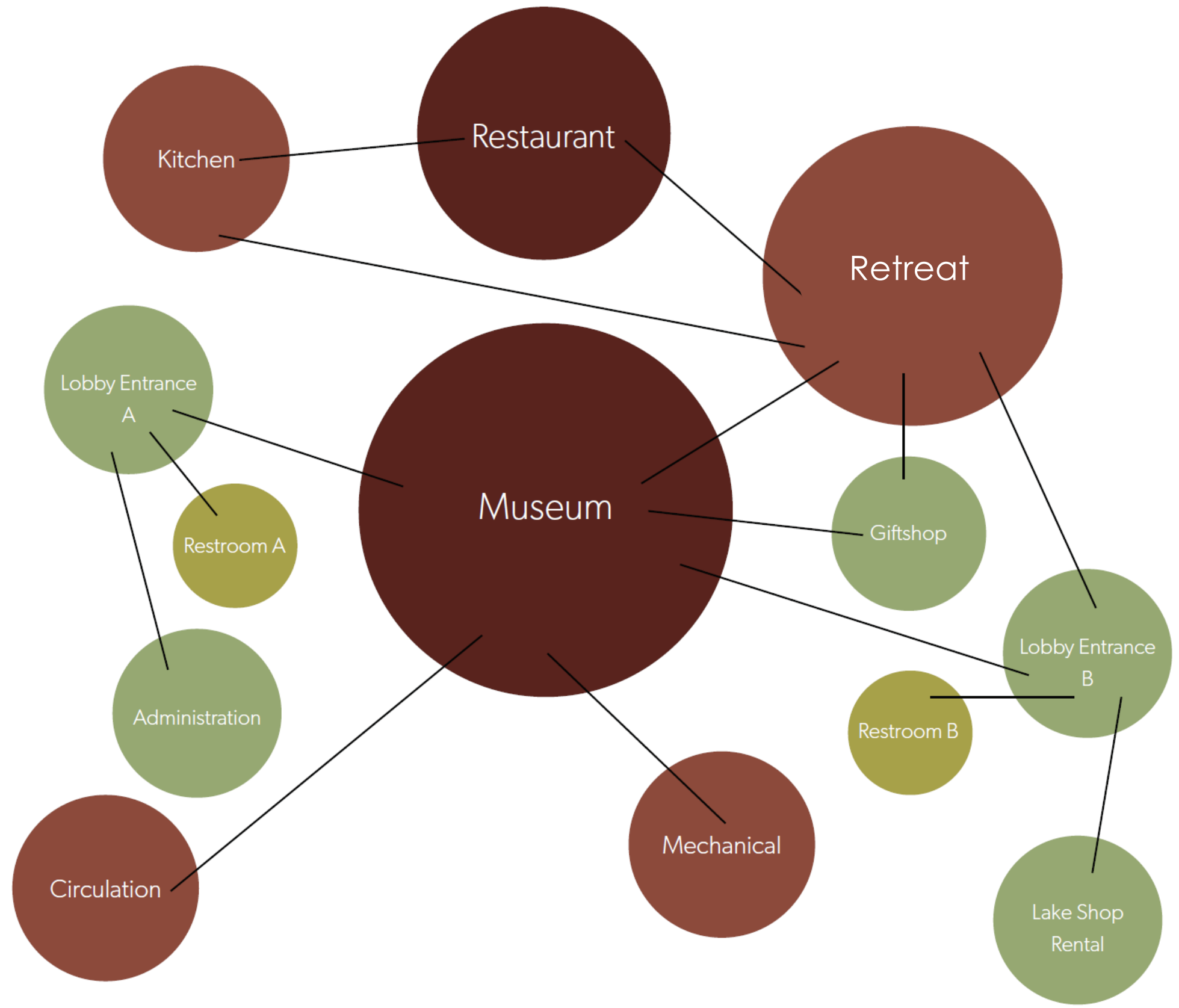

A BORDER..

- SEPARATES | DIVIDES | ORGANIZES
- EXCLUDES | INCLUDES
- IS CROSSABLE

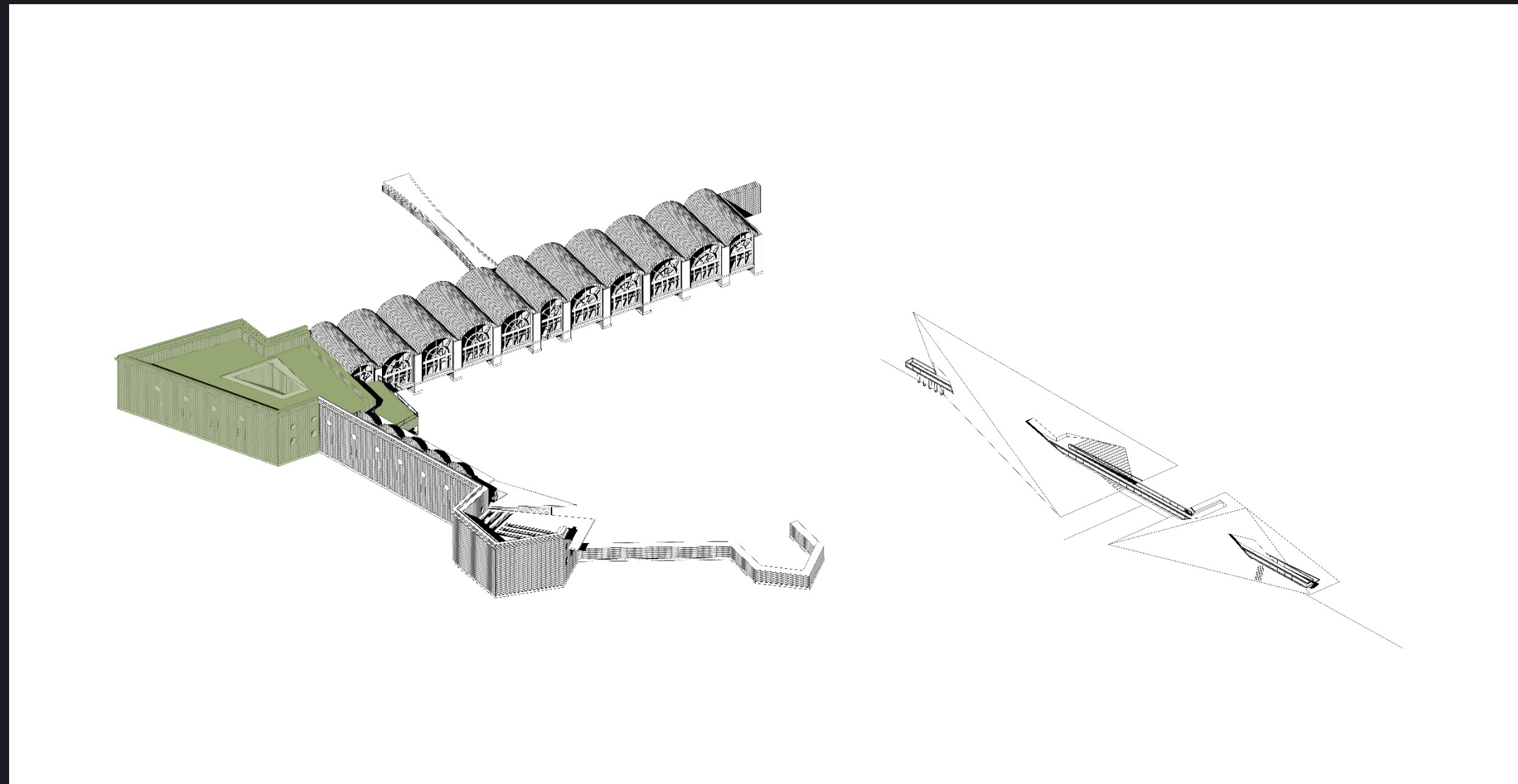
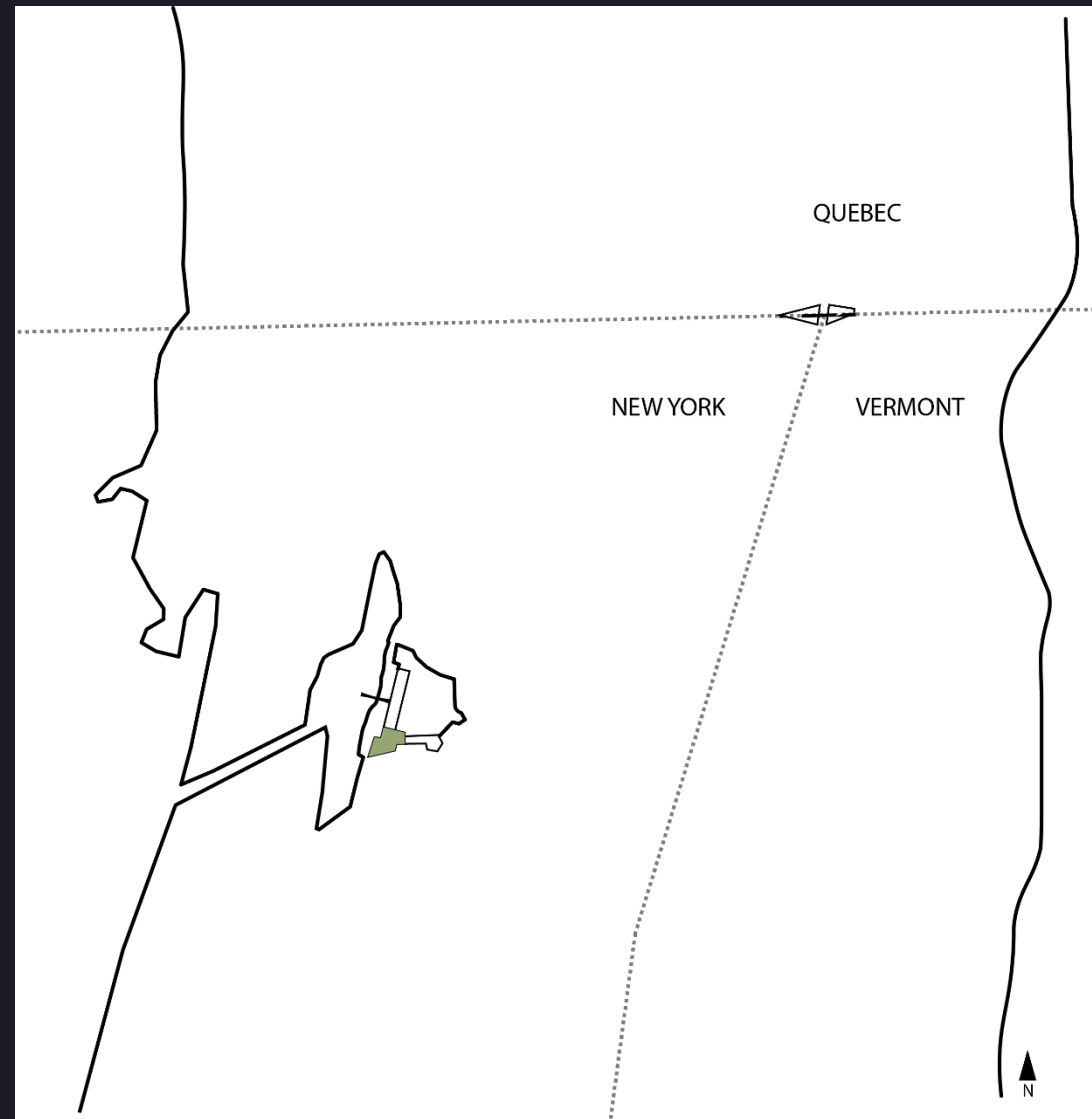

A BORDER..

- SEPARATES | DIVIDES | ORGANIZES
- EXCLUDES | INCLUDES
- IS CROSSABLE

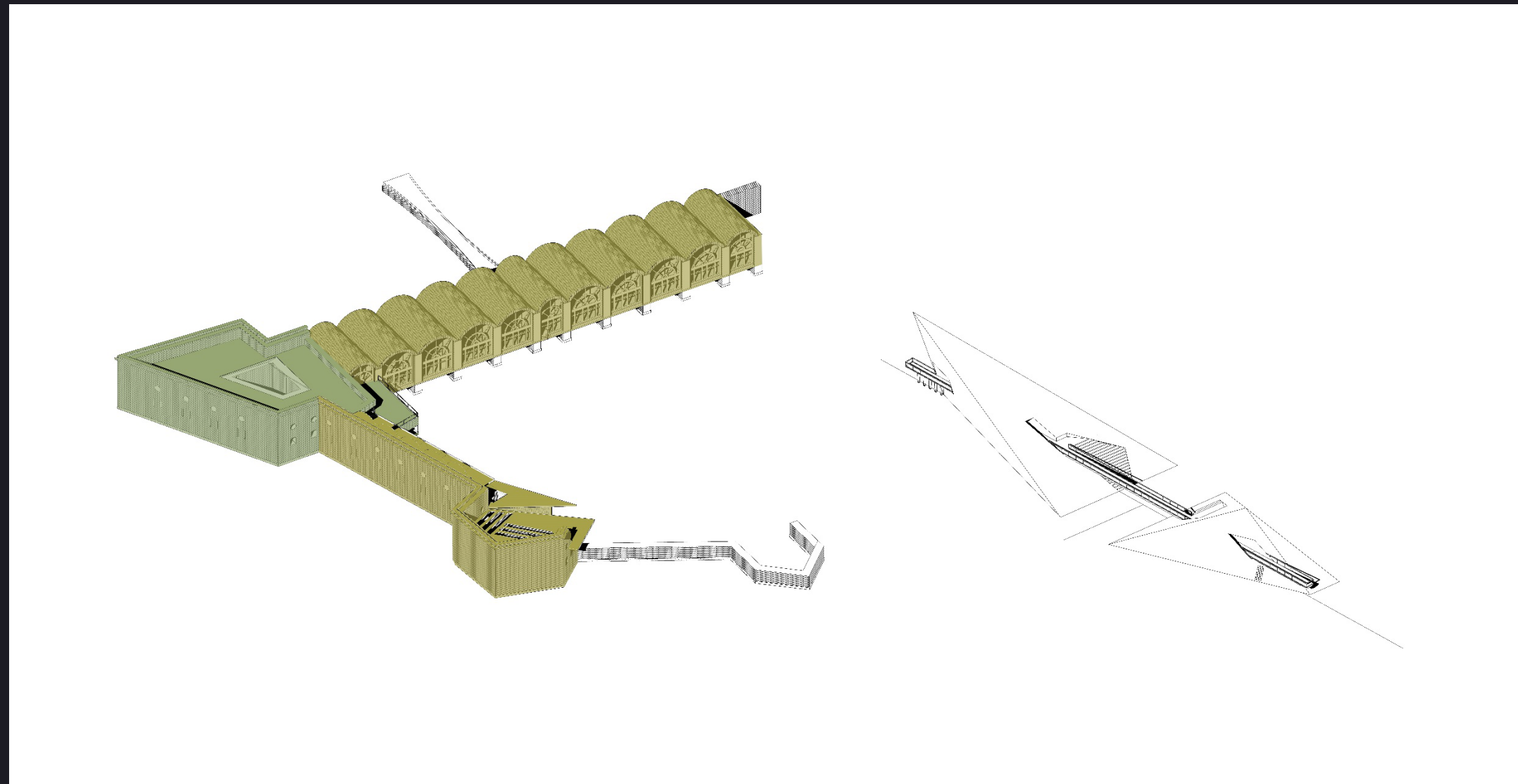
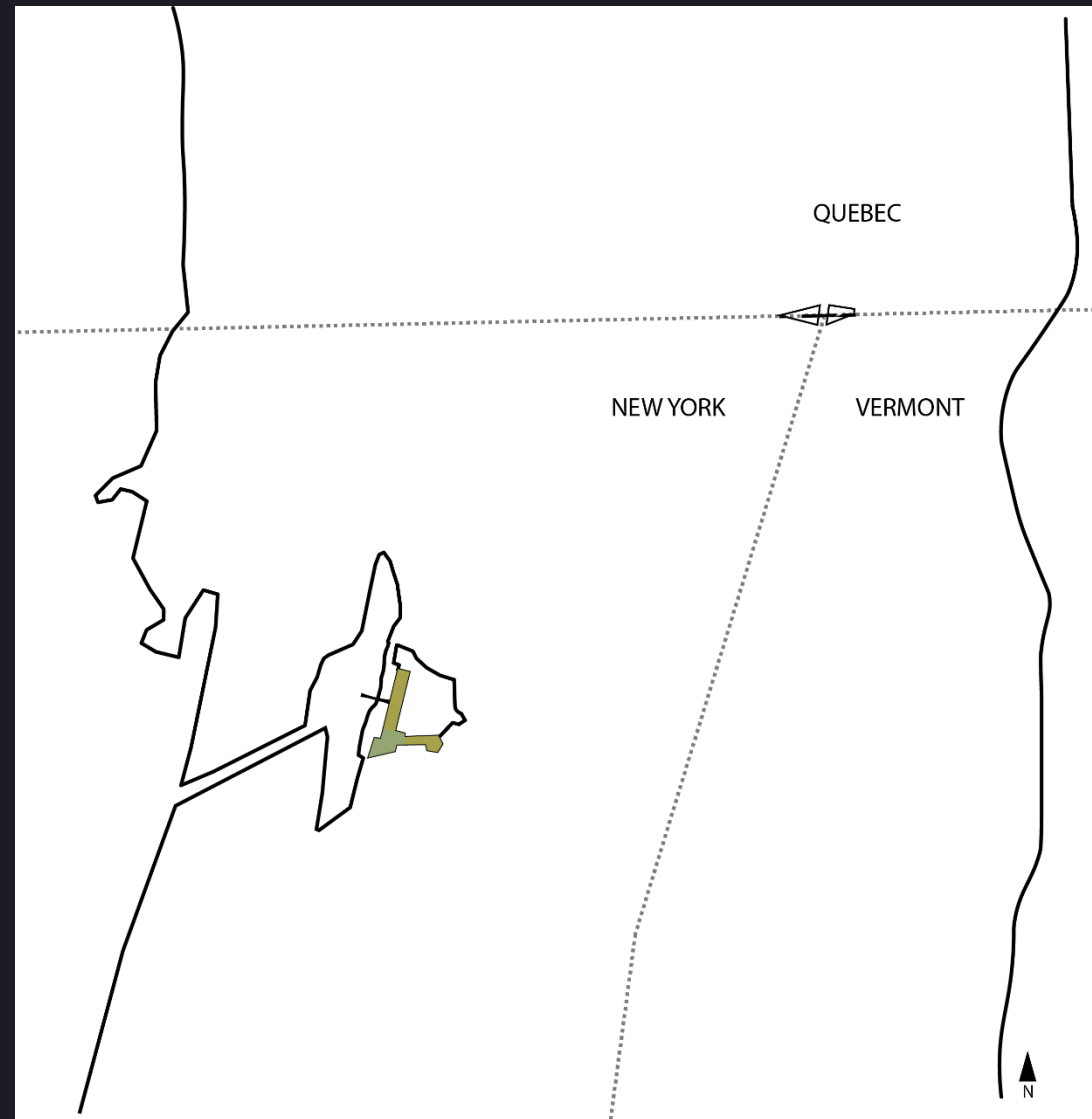

A BORDER..

- ✓ SEPARATES | DIVIDES | ORGANIZES
- ✓ EXCLUDES | INCLUDES
- ✓ IS CROSSABLE

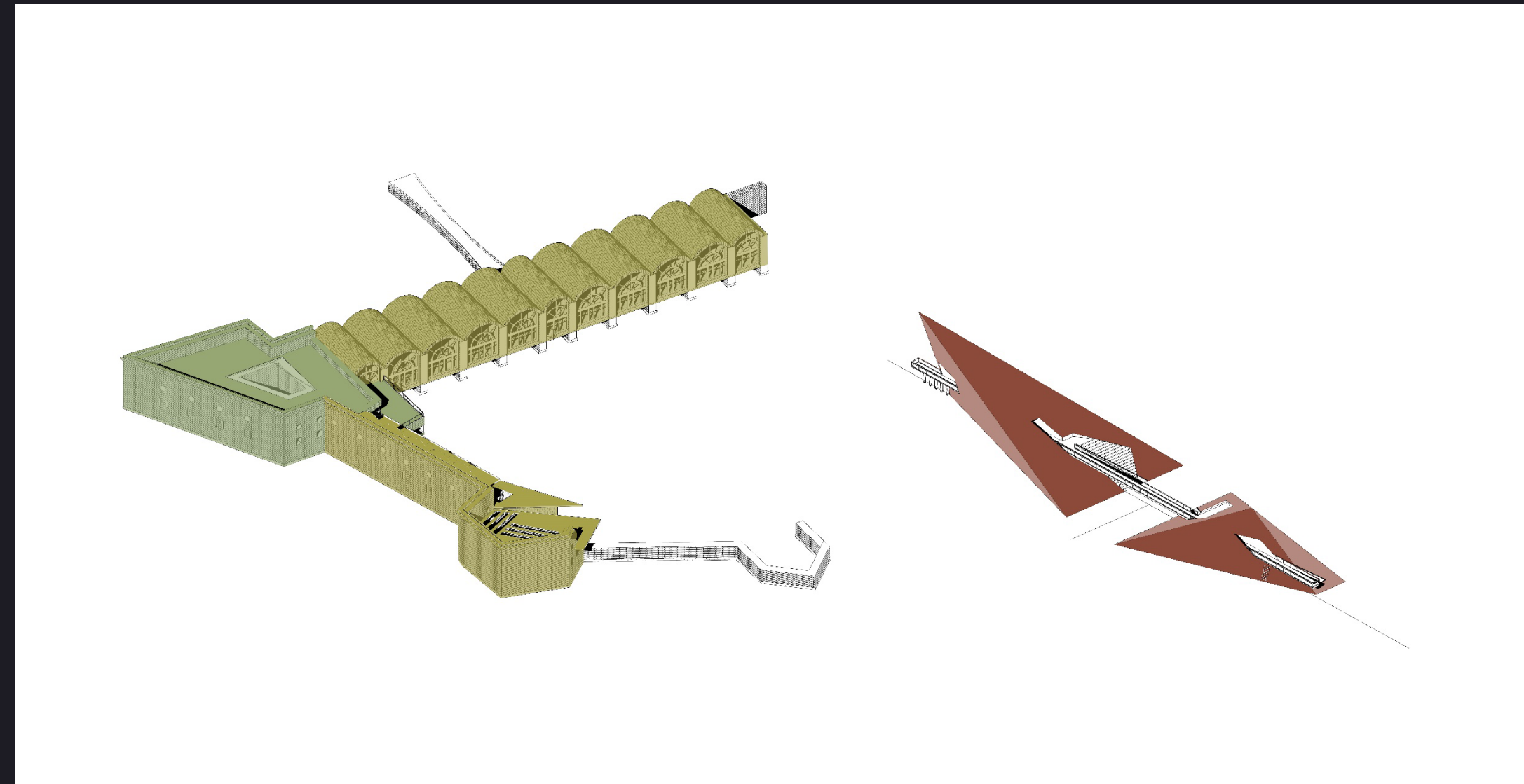
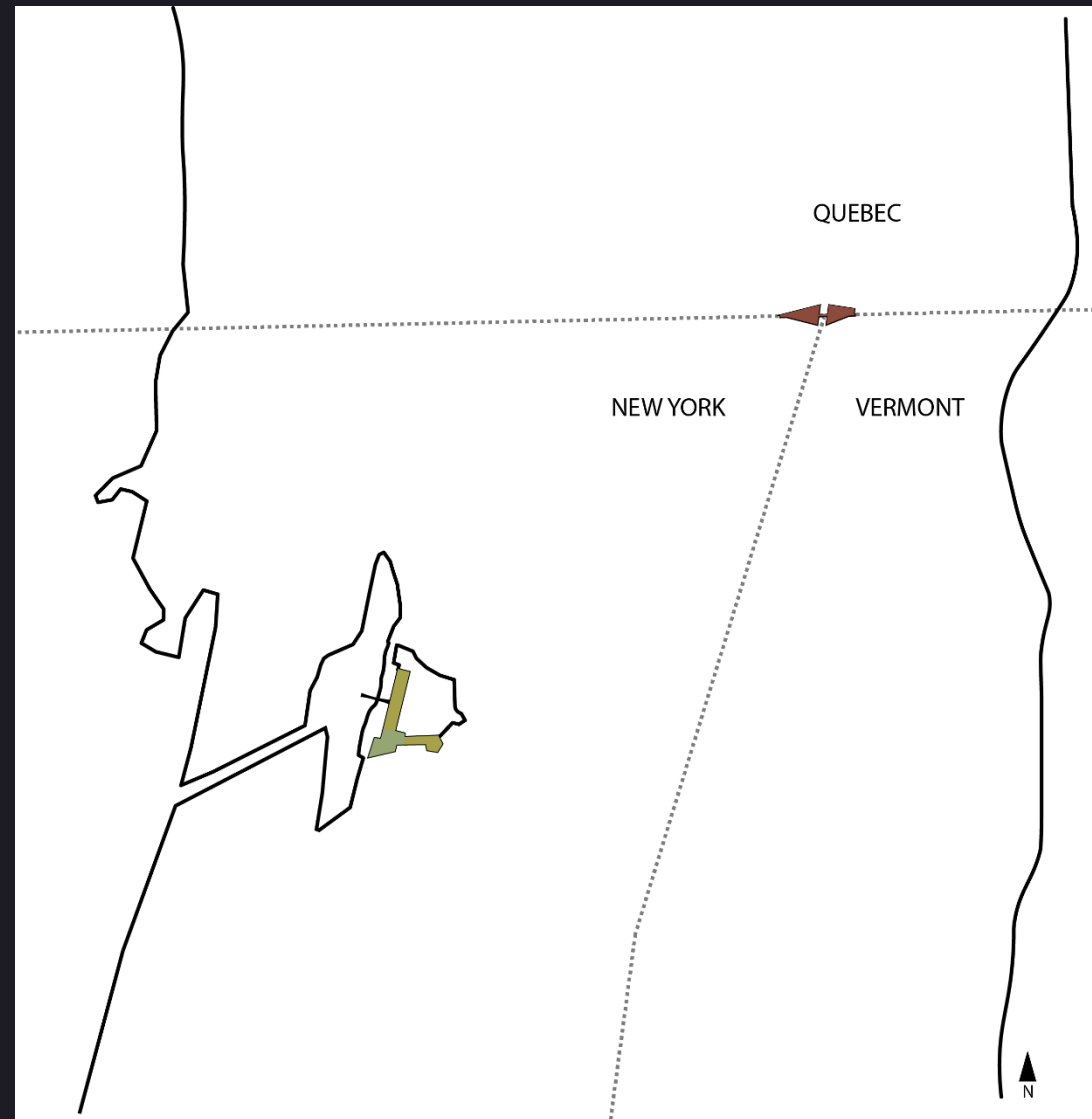

DESIGN RHYTHM

A design rhythm was investigated through the mapping of different intersections.

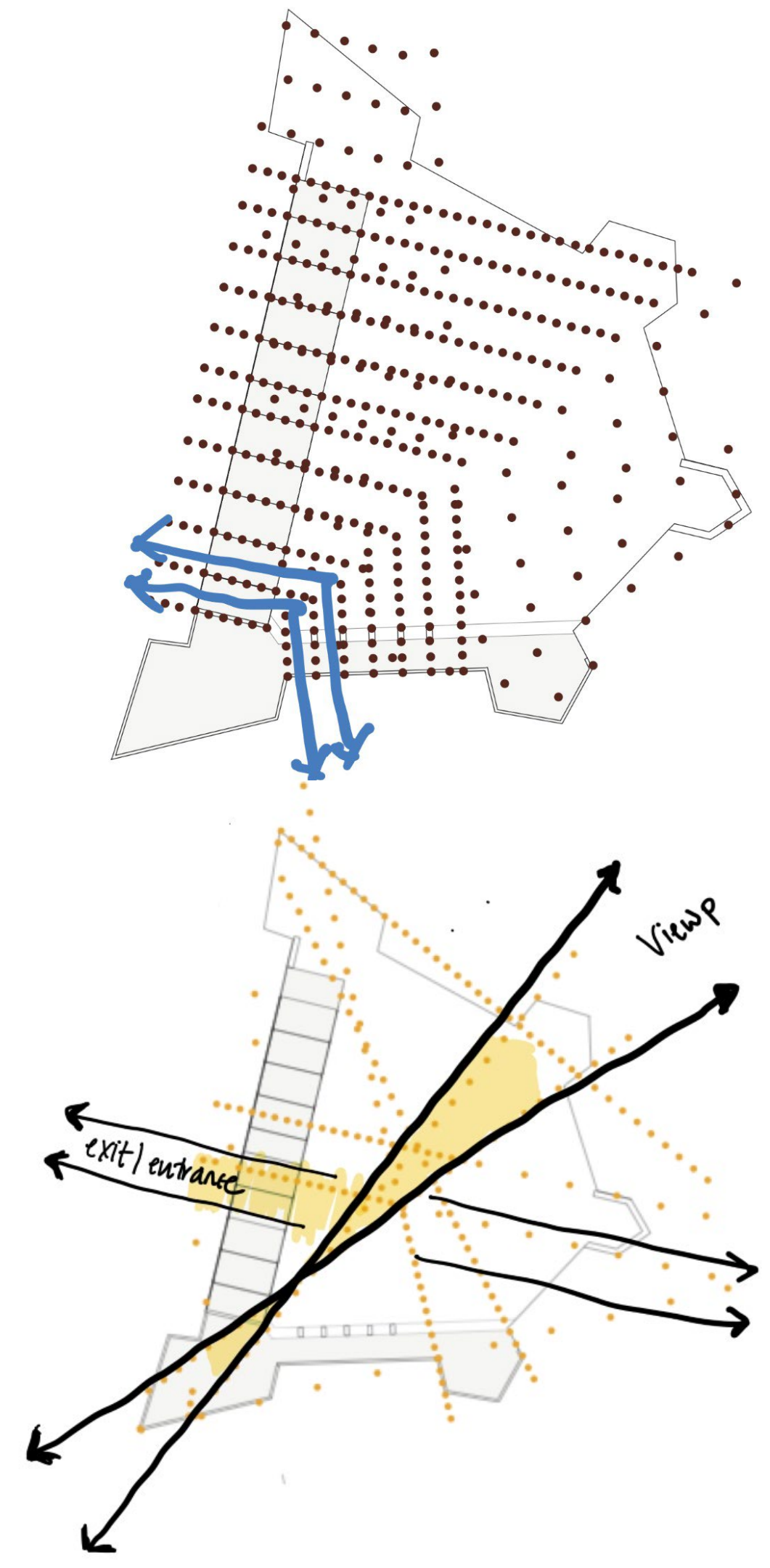
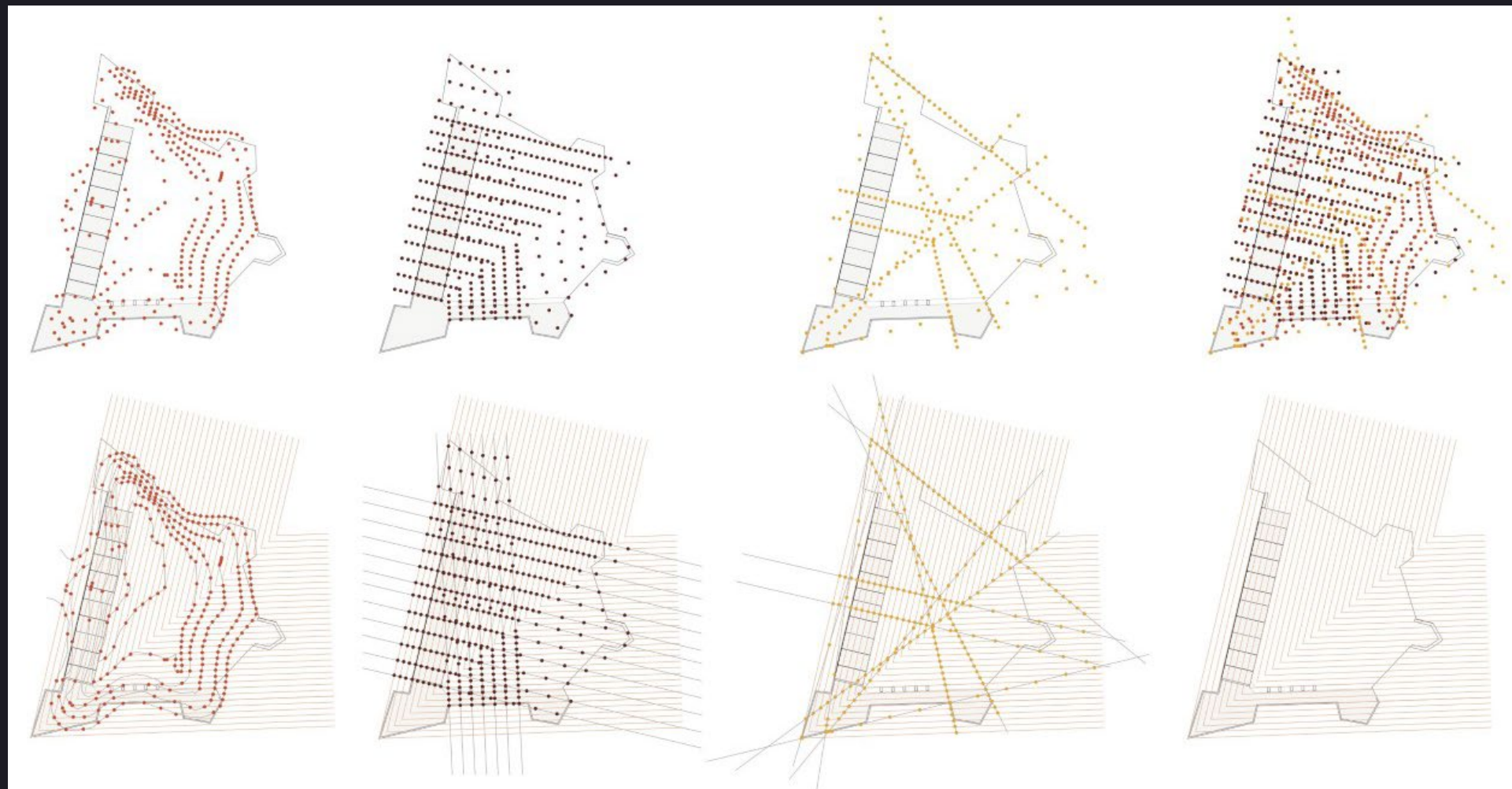

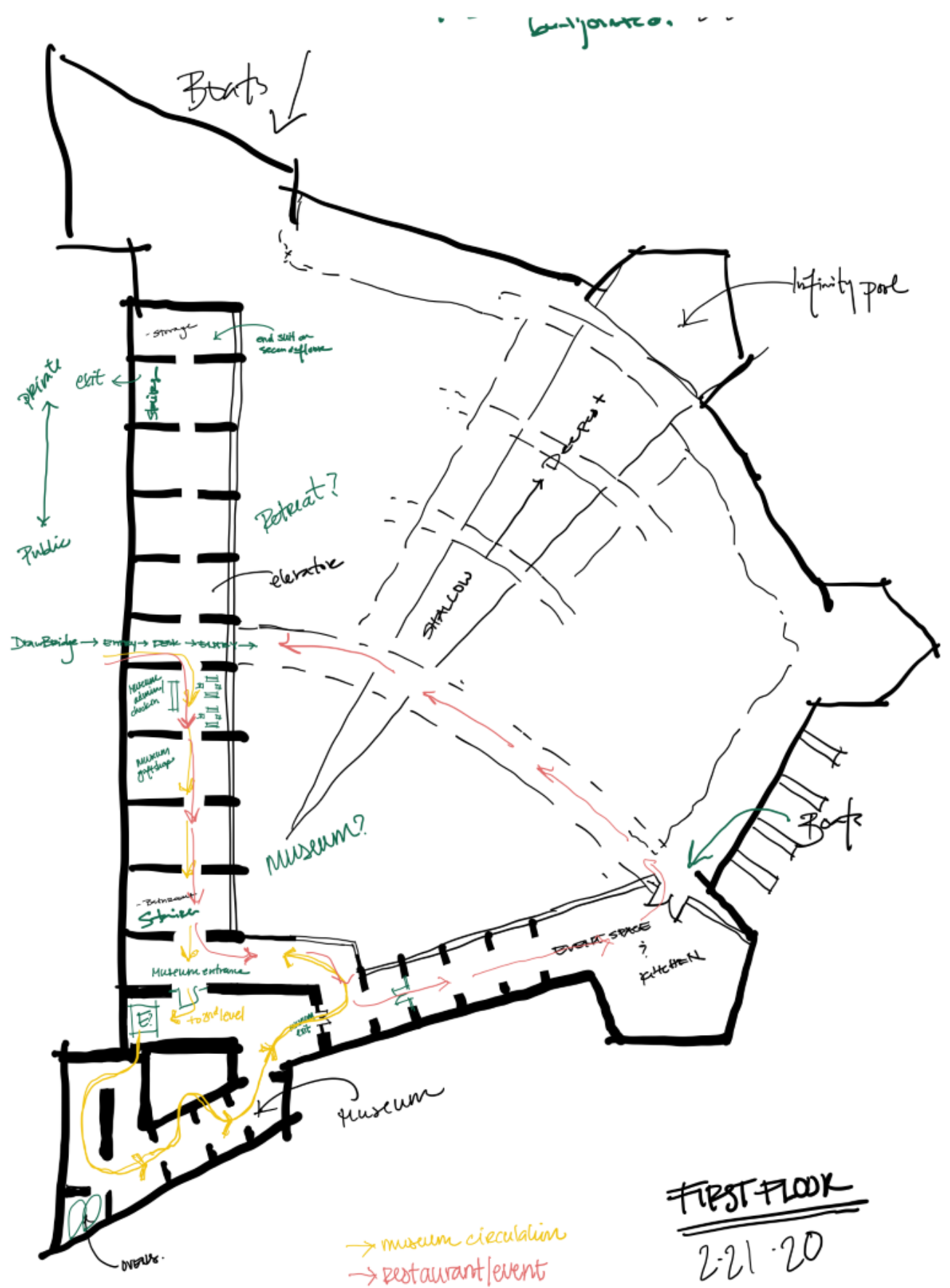

→ museum circulation
 → restaurant/event

FIRST FLOOR
 2-21-20

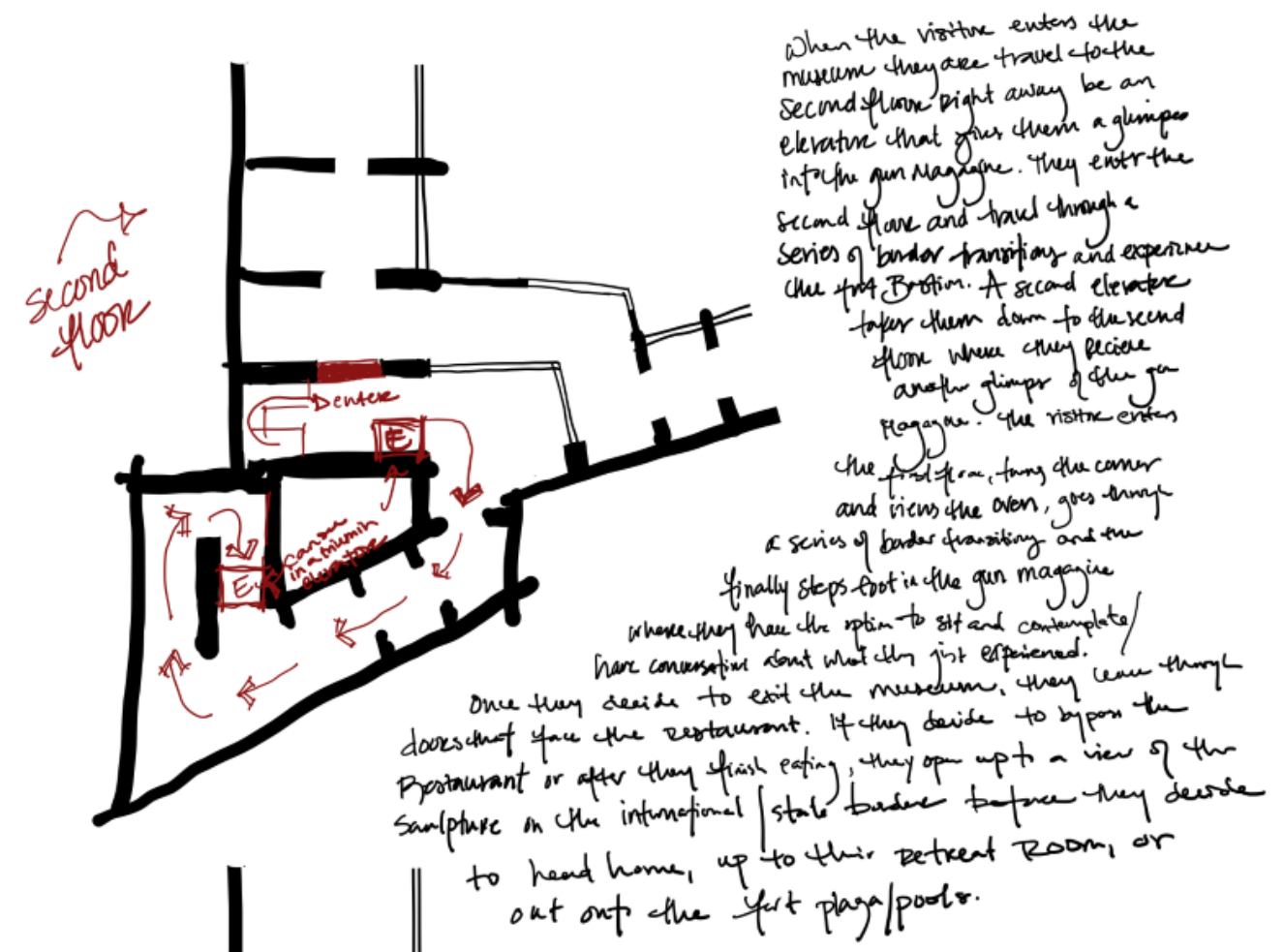

When the visitor enters the museum they are taken to the second floor right away by an elevator that gives them a glimpse into the gun magazine. They enter the second floor and travel through a series of border transitions and experience the first Boston. A second elevator takes them down to the second floor where they receive another glimpse of the gun magazine. The visitor enters the first floor, turns the corner and views the view, goes through a series of border transitions and finally steps foot in the gun magazine where they have the option to sit and contemplate/ have conversation about what they just experienced. Once they decide to exit the museum, they leave through the restaurant or after they finish eating, they open up to a view of the sculpture on the international state before they decide to head home, up to their retreat room, or out onto the first plaza/pools.

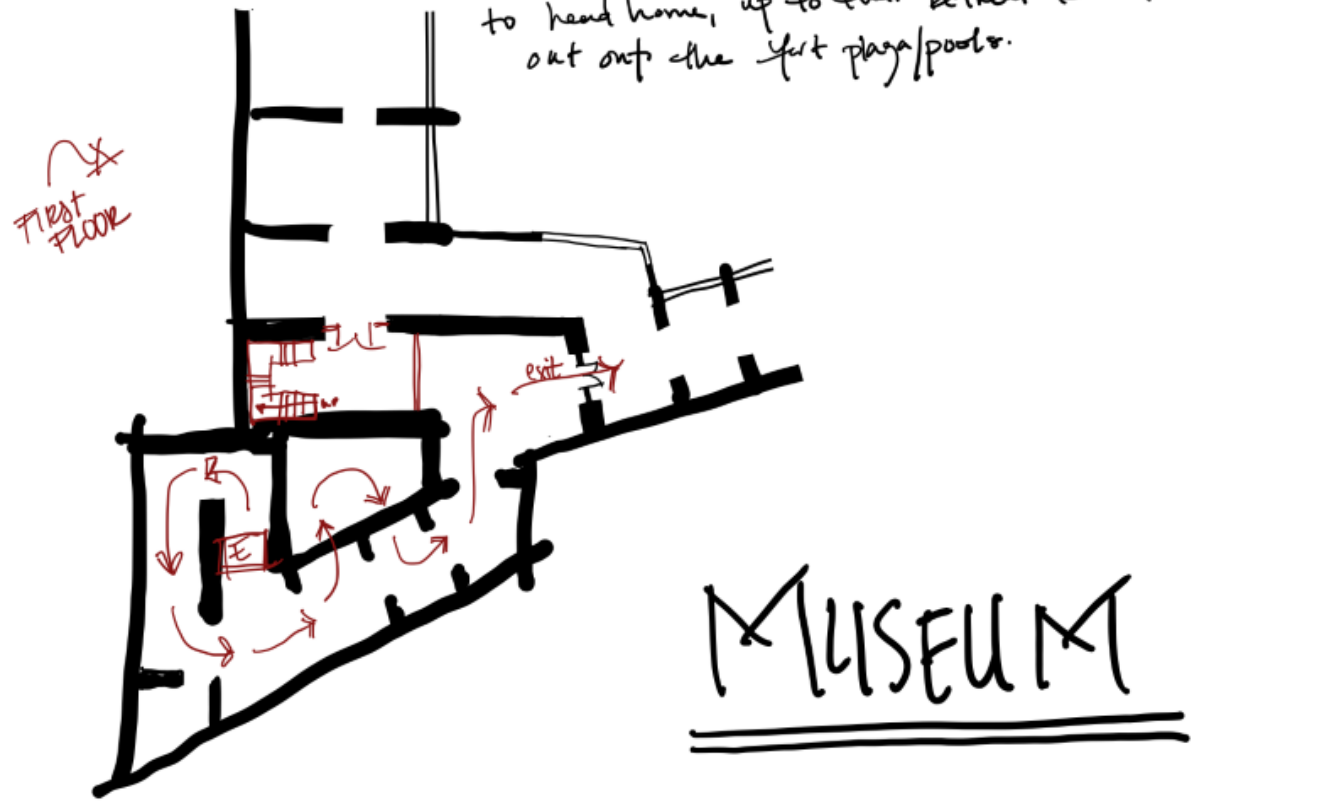



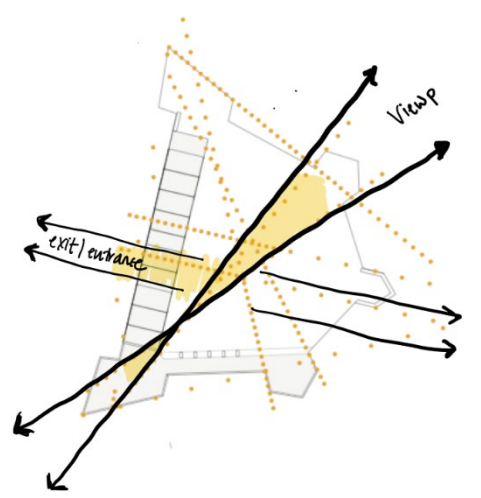
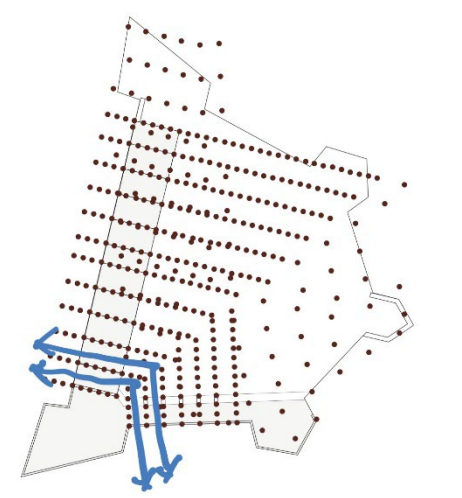

SITE PLAN



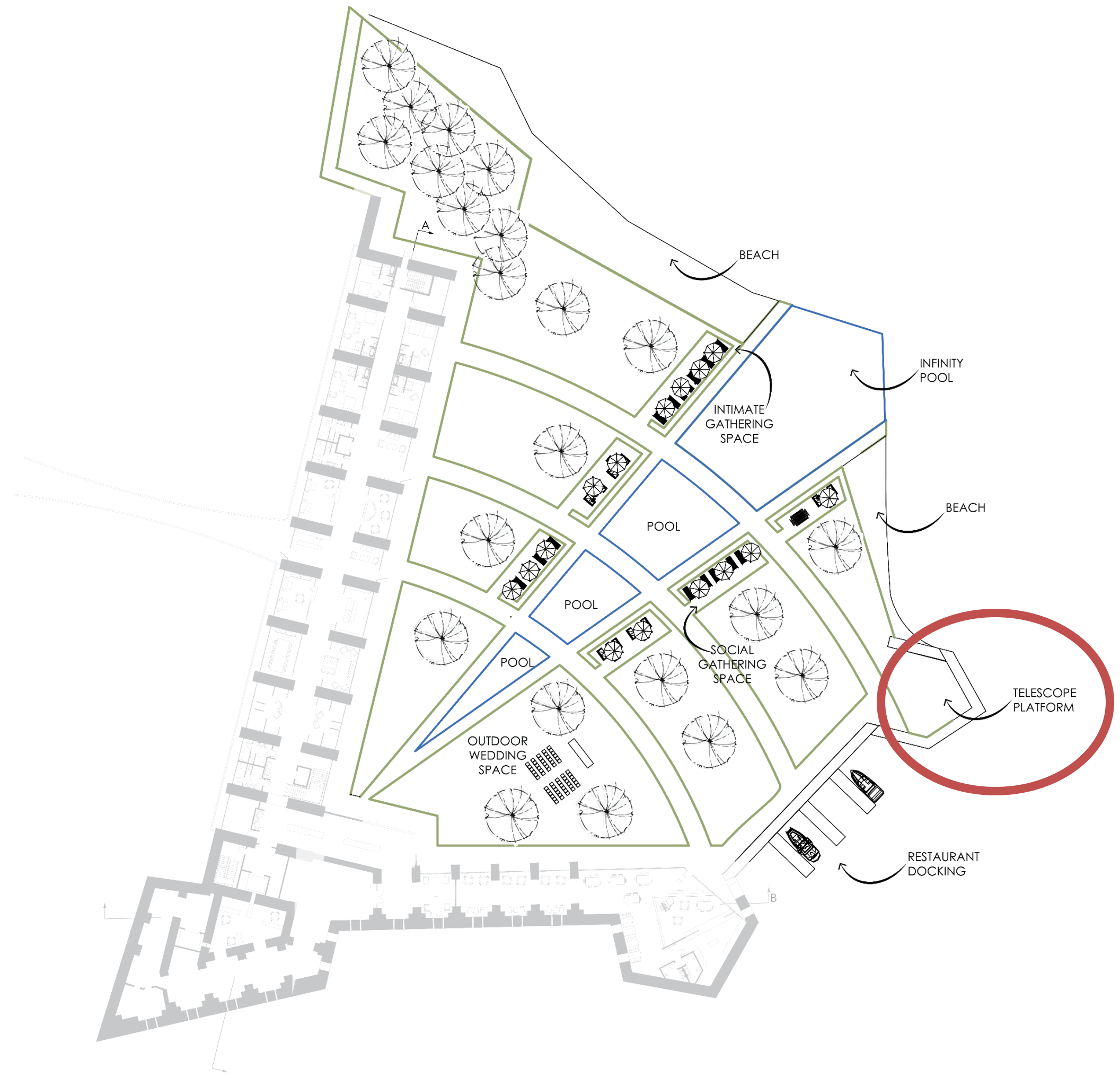



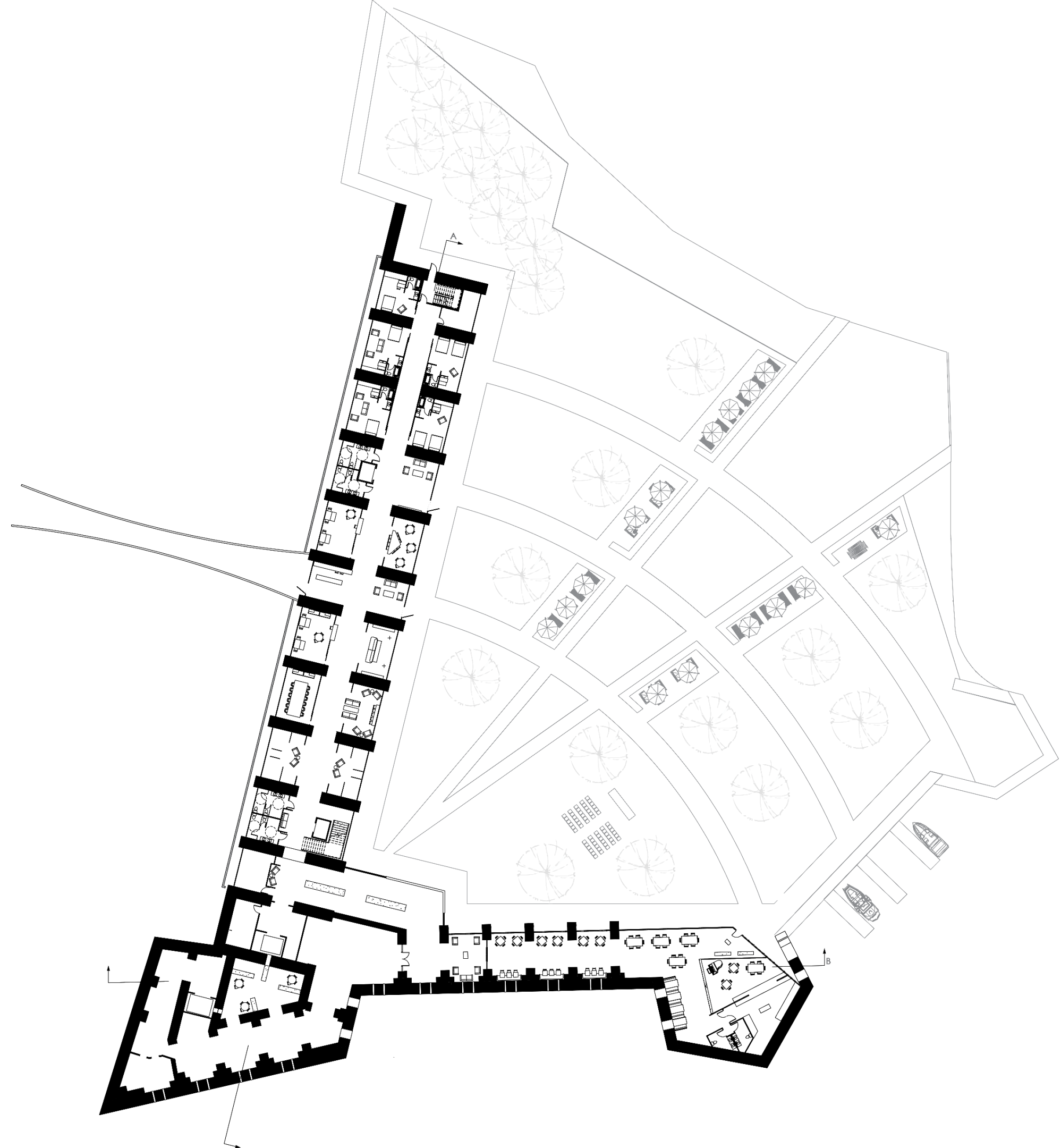

FIRST FLOOR PLAN



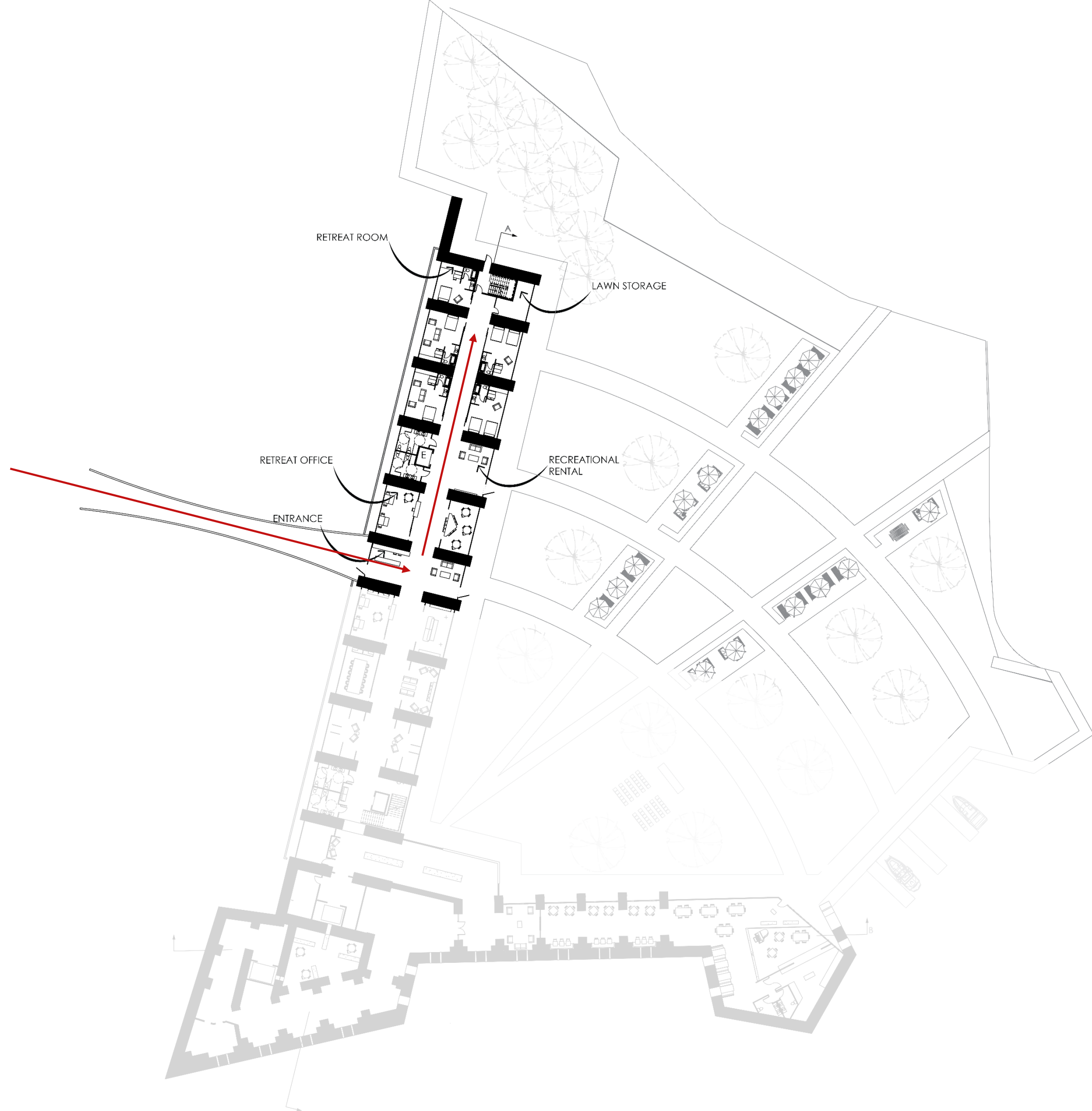

RETREAT- PRIVATE
FIRST FLOOR PLAN

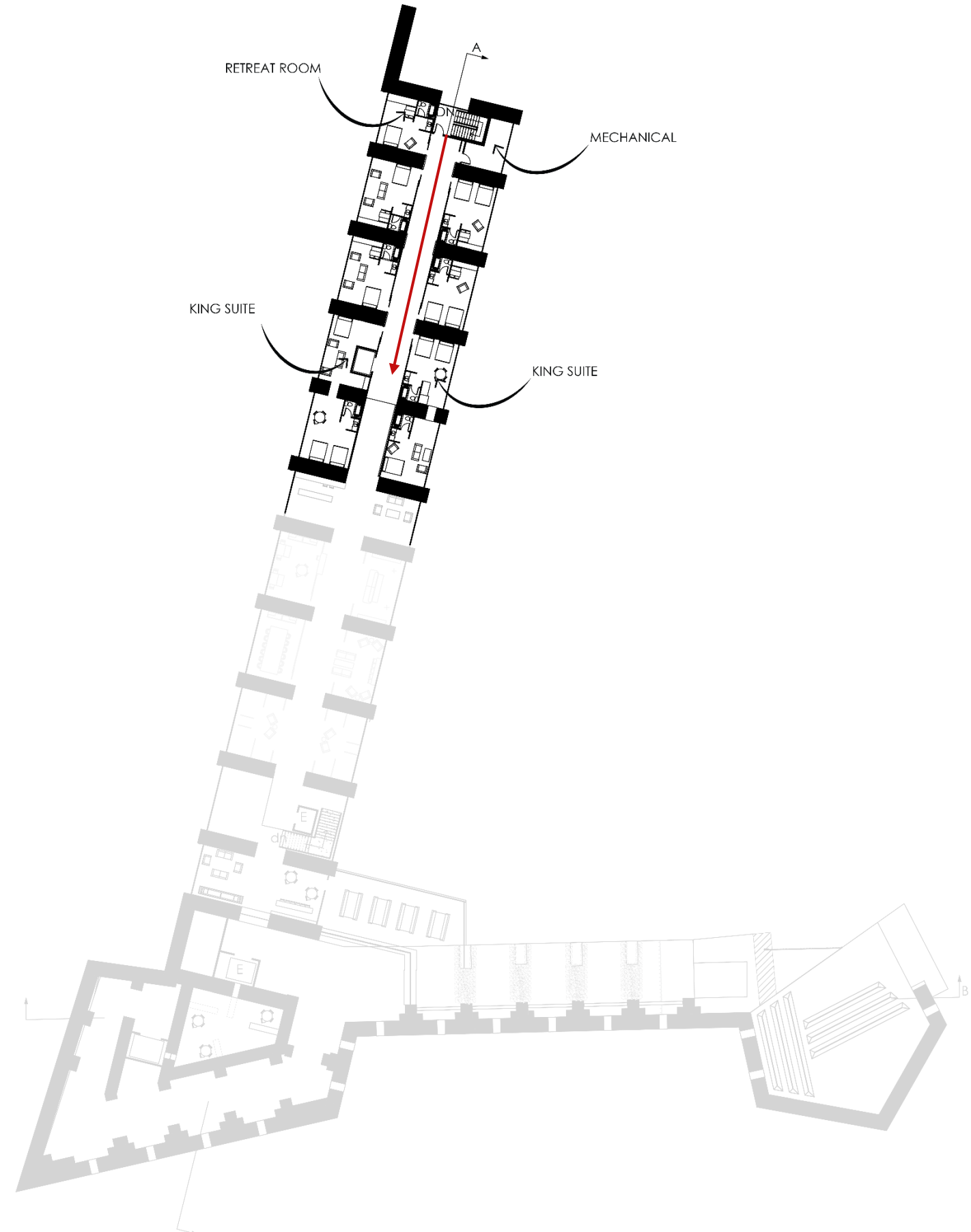

RETREAT- PRIVATE

SECOND FLOOR PLAN



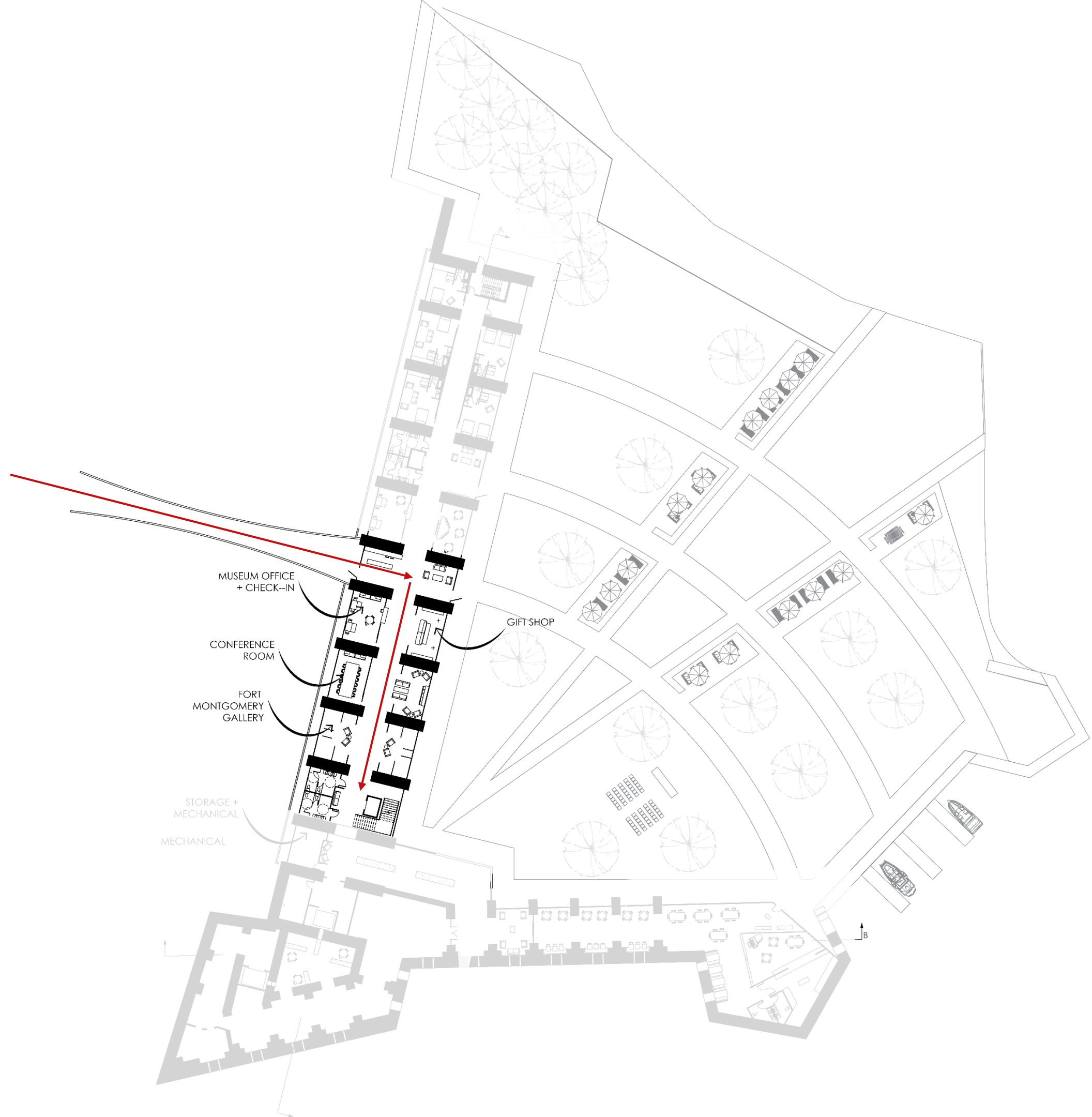

RETREAT- PUBLIC

FIRST FLOOR PLAN





MUSEUM

FIRST FLOOR PLAN



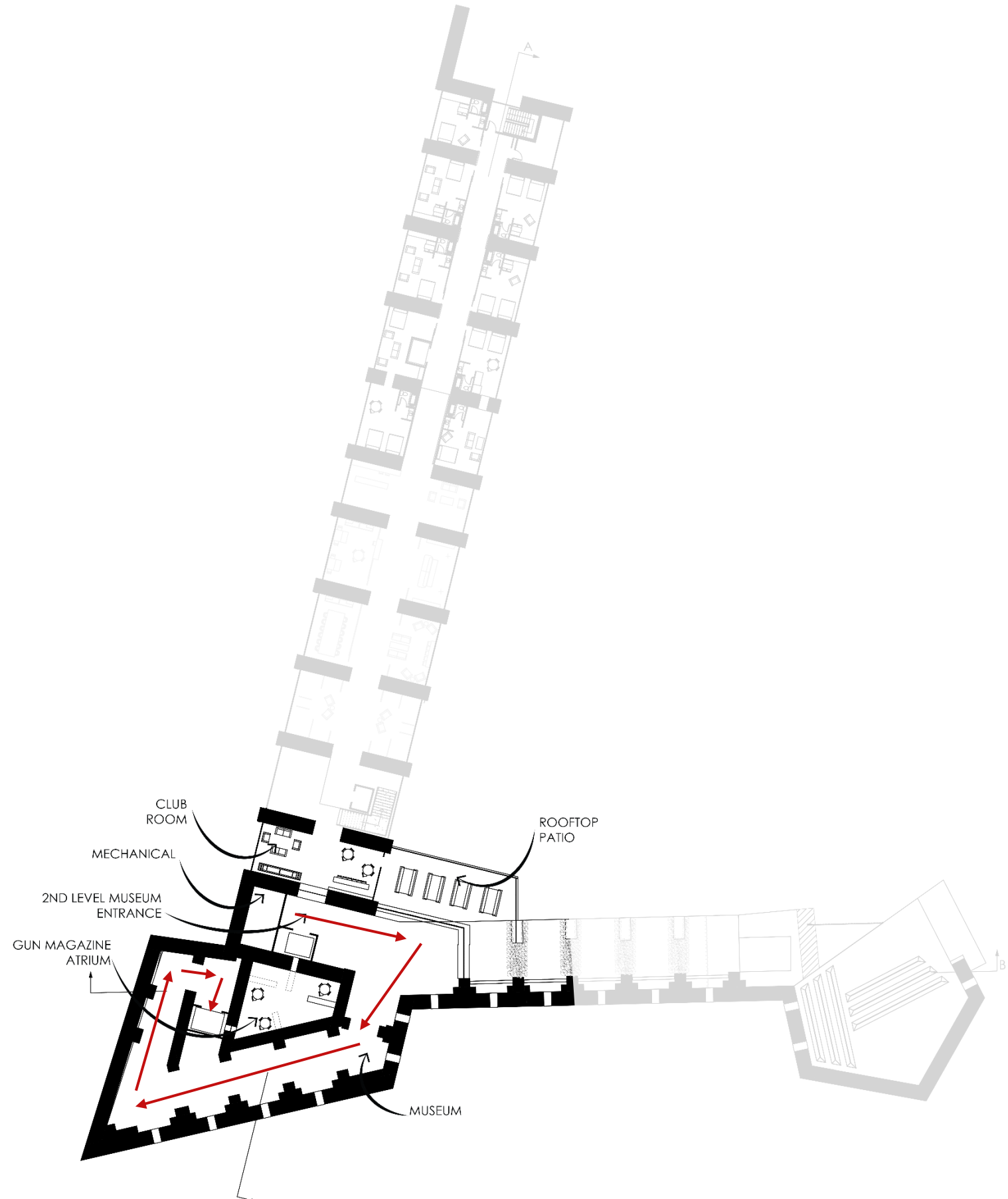

MUSEUM
SECOND FLOOR PLAN



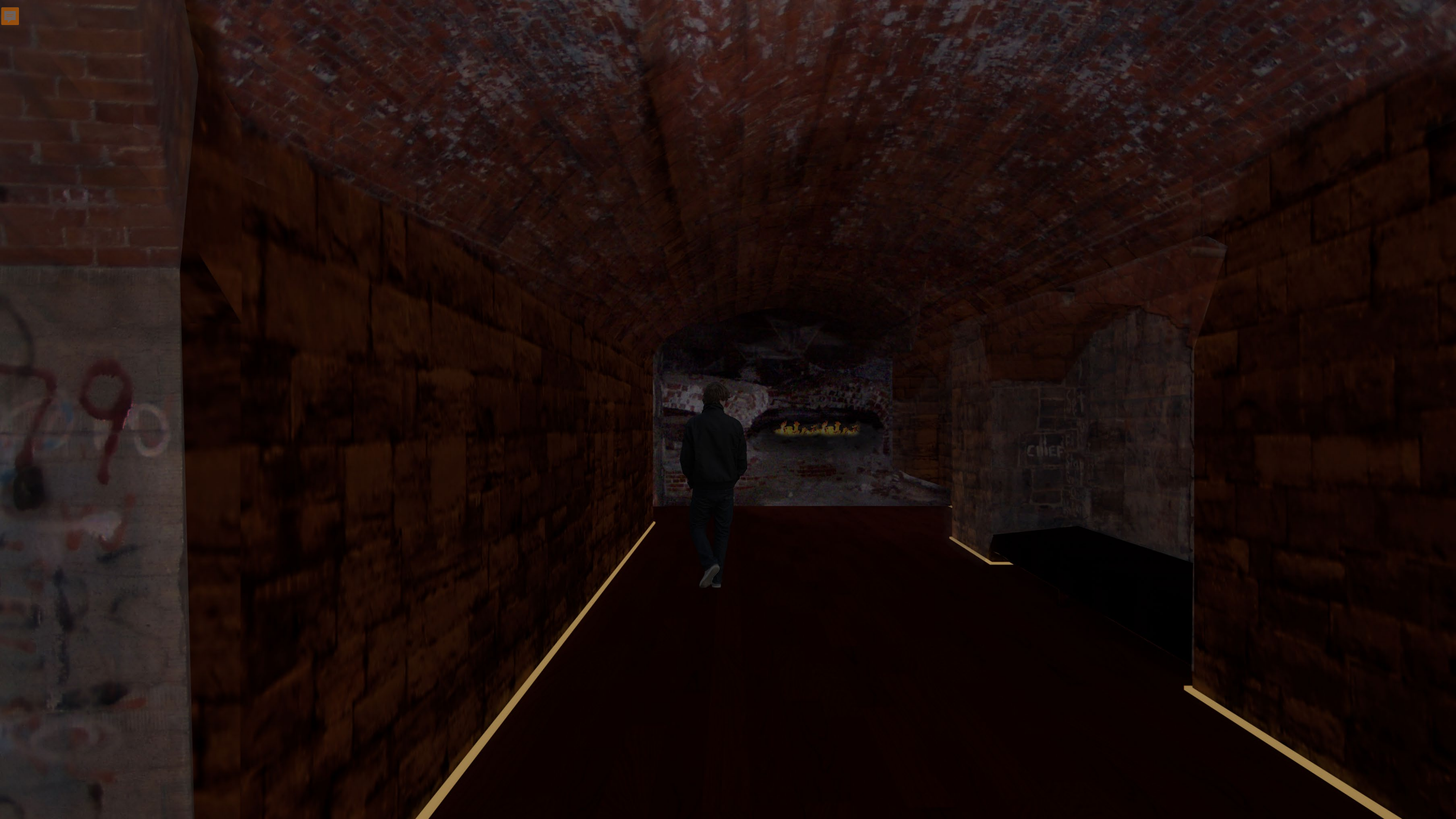

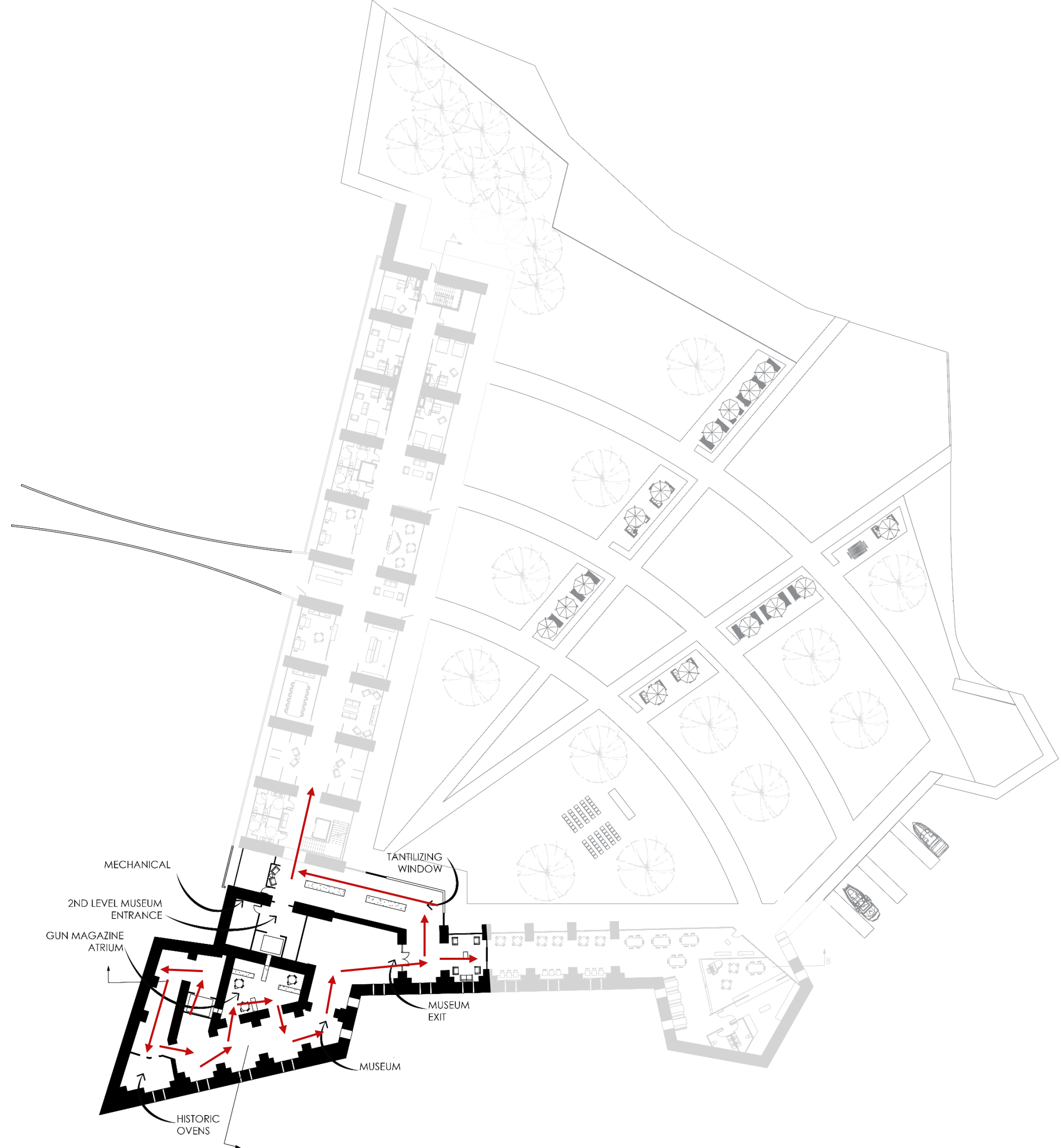

MUSEUM

FIRST FLOOR PLAN



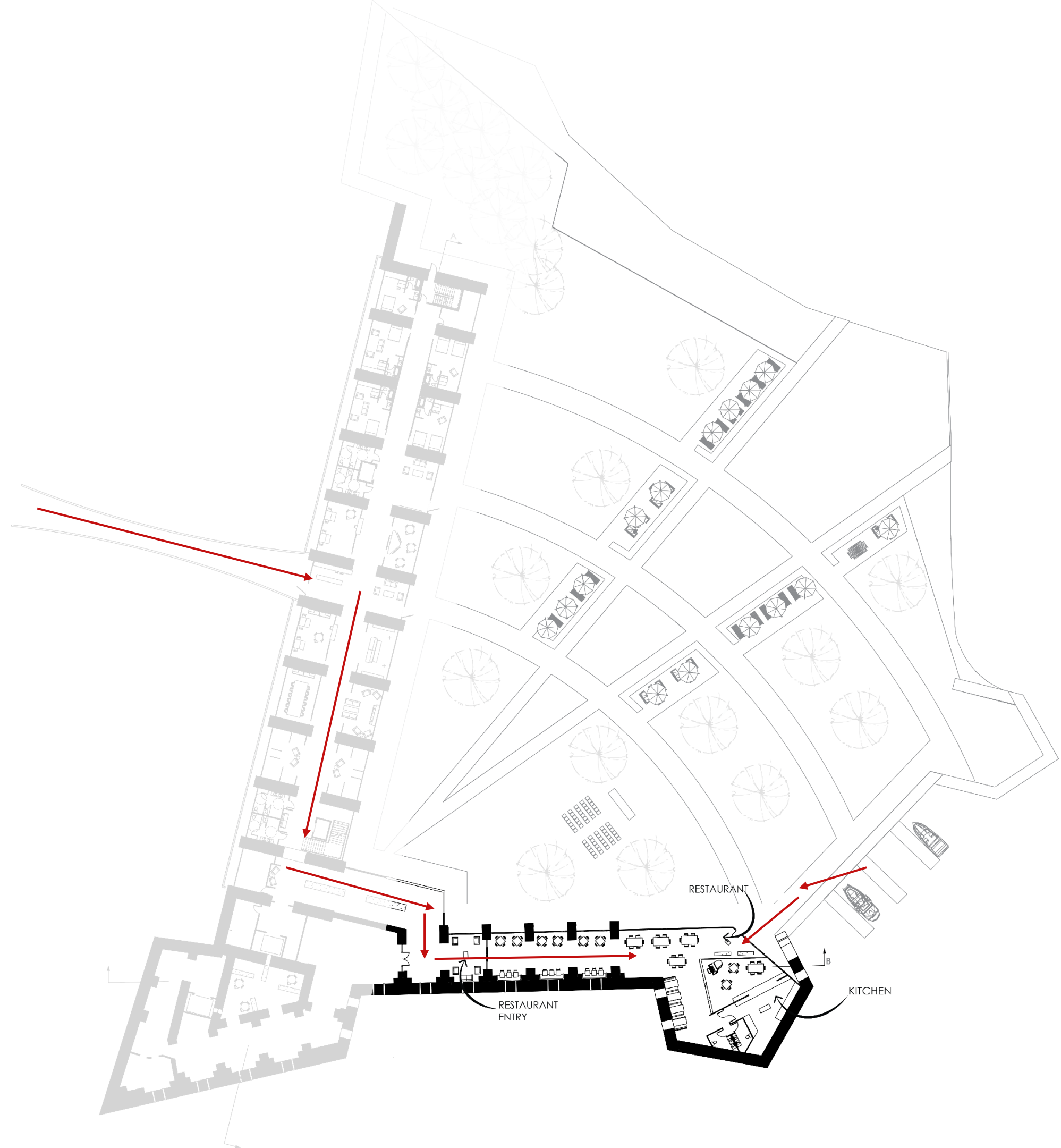

RESTAURANT
FIRST FLOOR PLAN



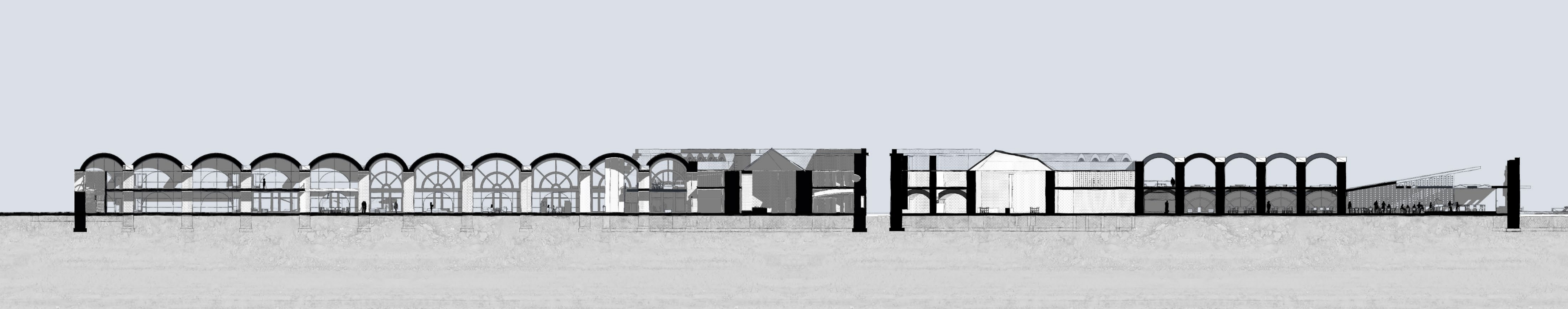

SECTION A

SECTION B

ZONE 1

ZONE 2

ZONE 3



SECTION A
MECHANICAL SECTION





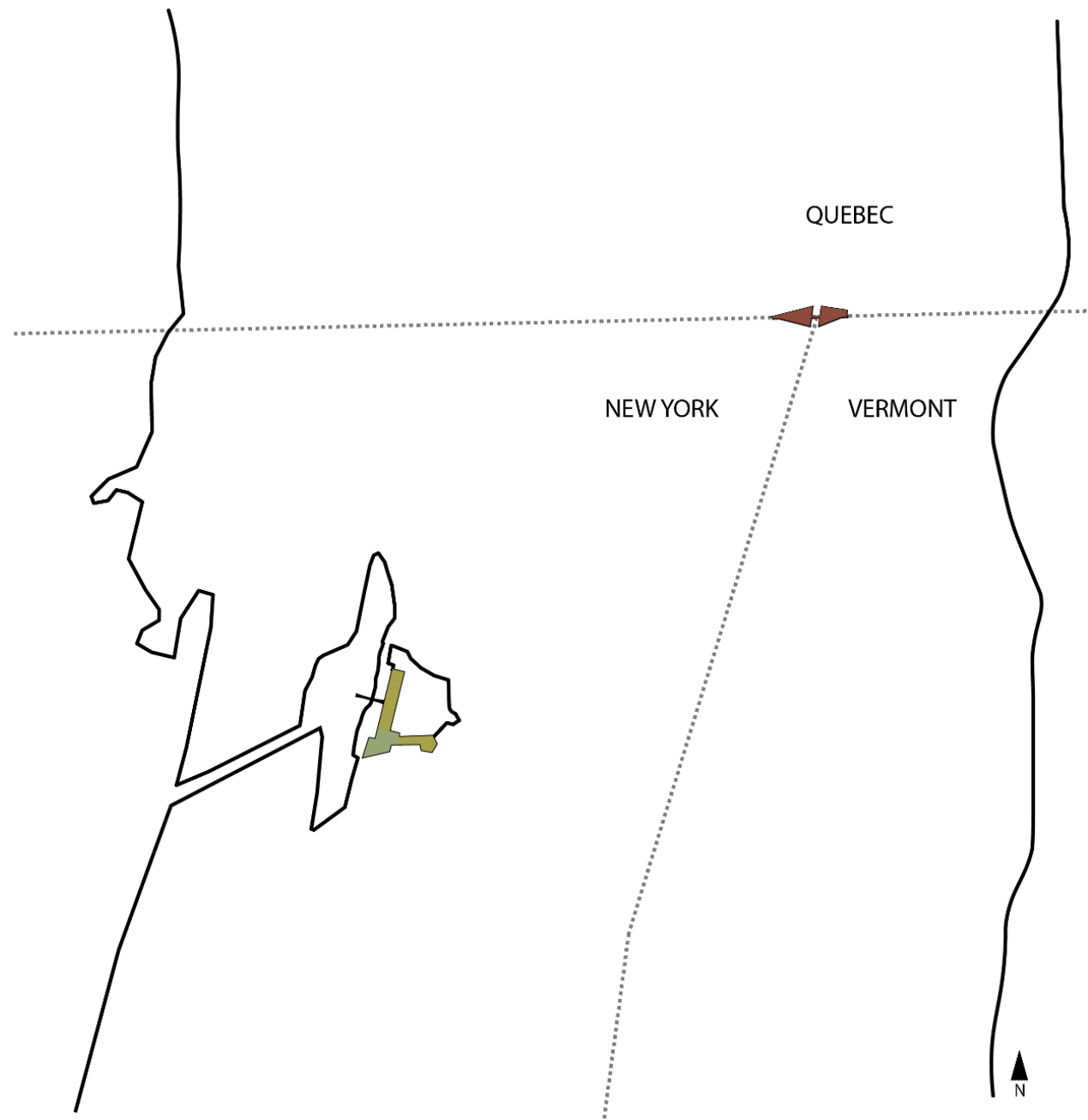



“I consider the monuments to be true hybrids, existing between art & architecture, they have a specific need or function, yet their function is purely symbolic.”

-Maya Lin



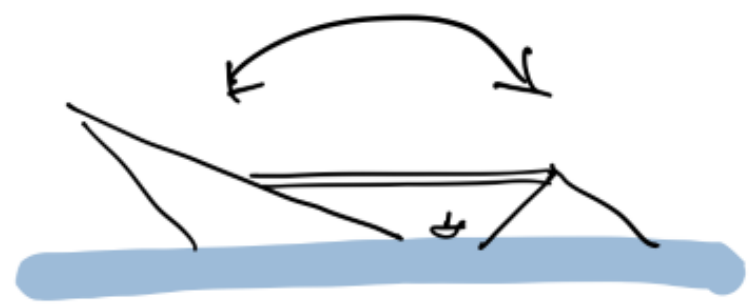
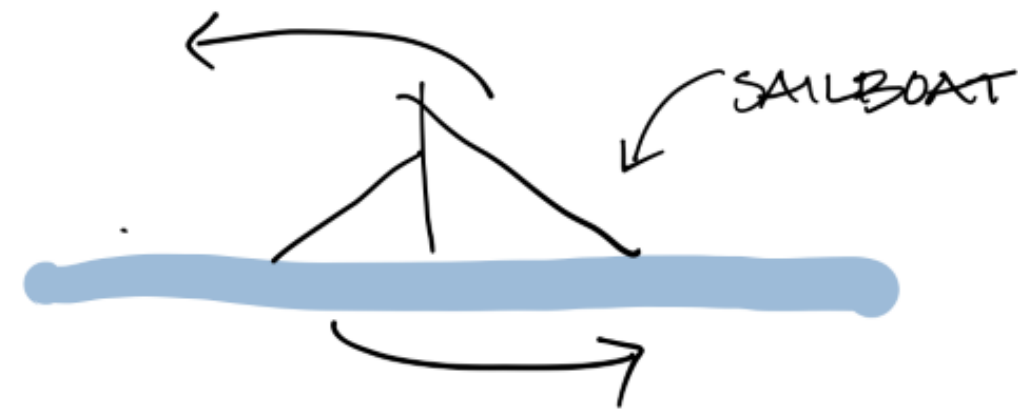
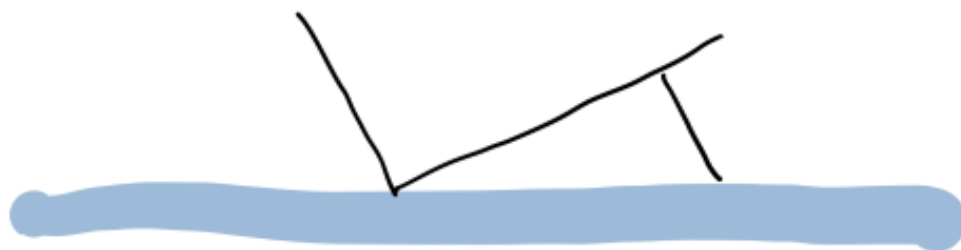

REFLECT SAILS

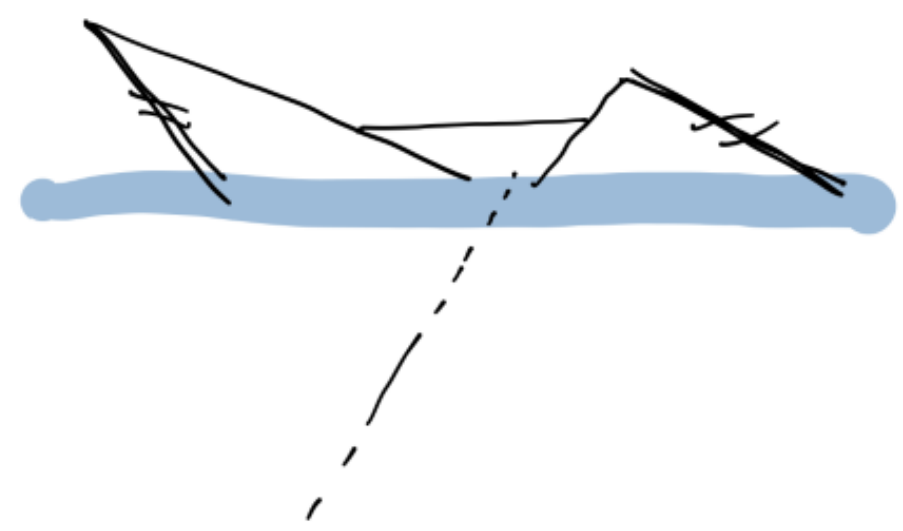

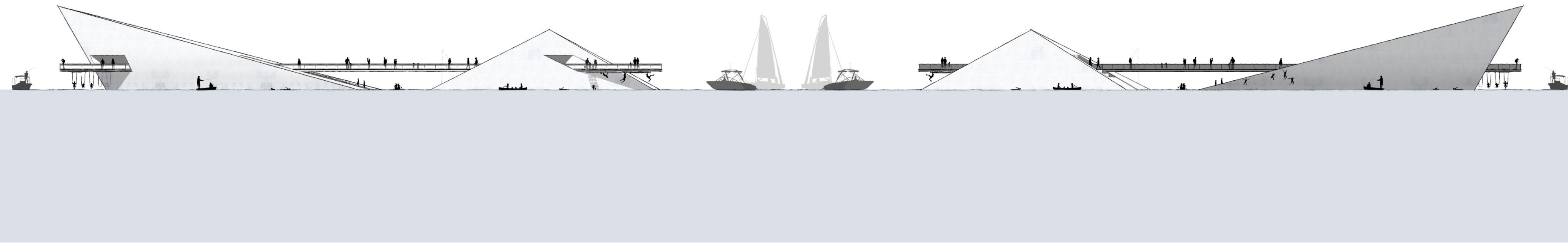

SOUTH ELEVATION

NORTH ELEVATION

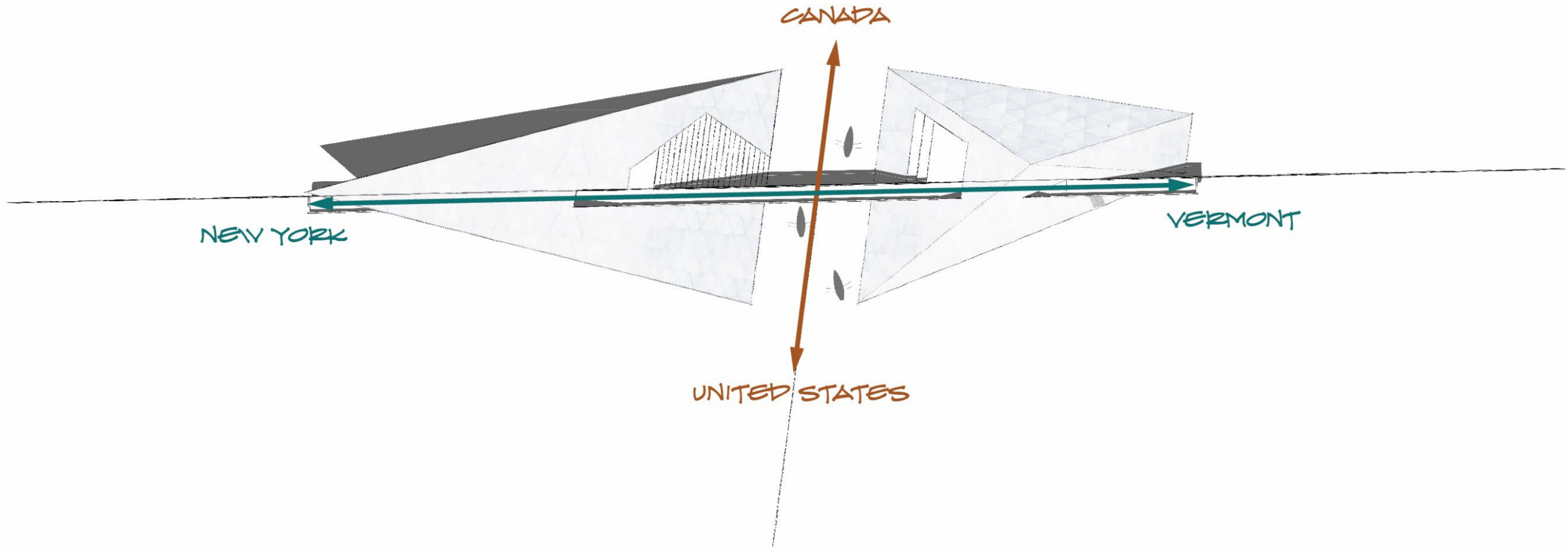

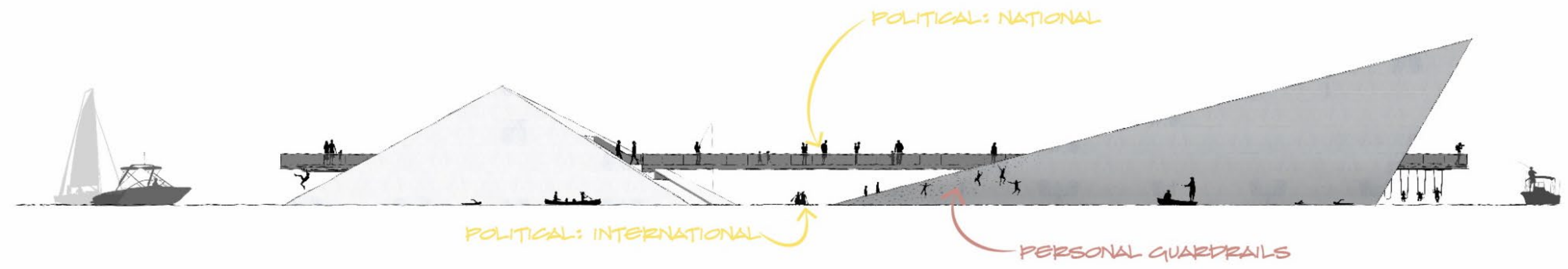
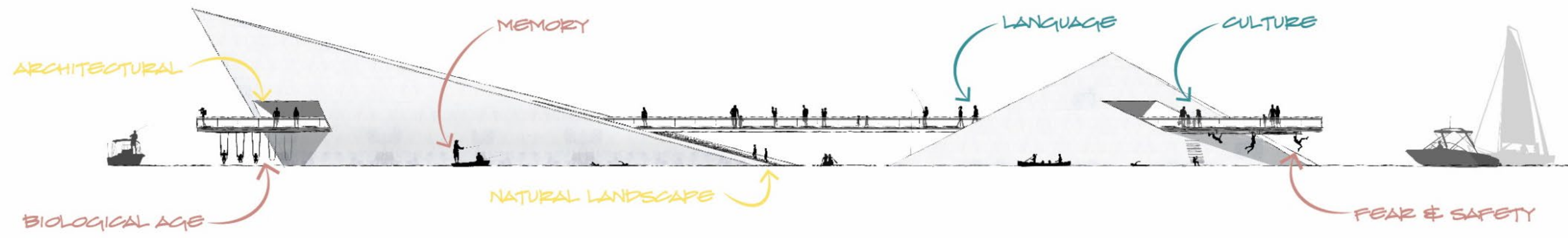

MONUMENT

BORDERS





Thank you!