

# CREATIVE SYNERGY

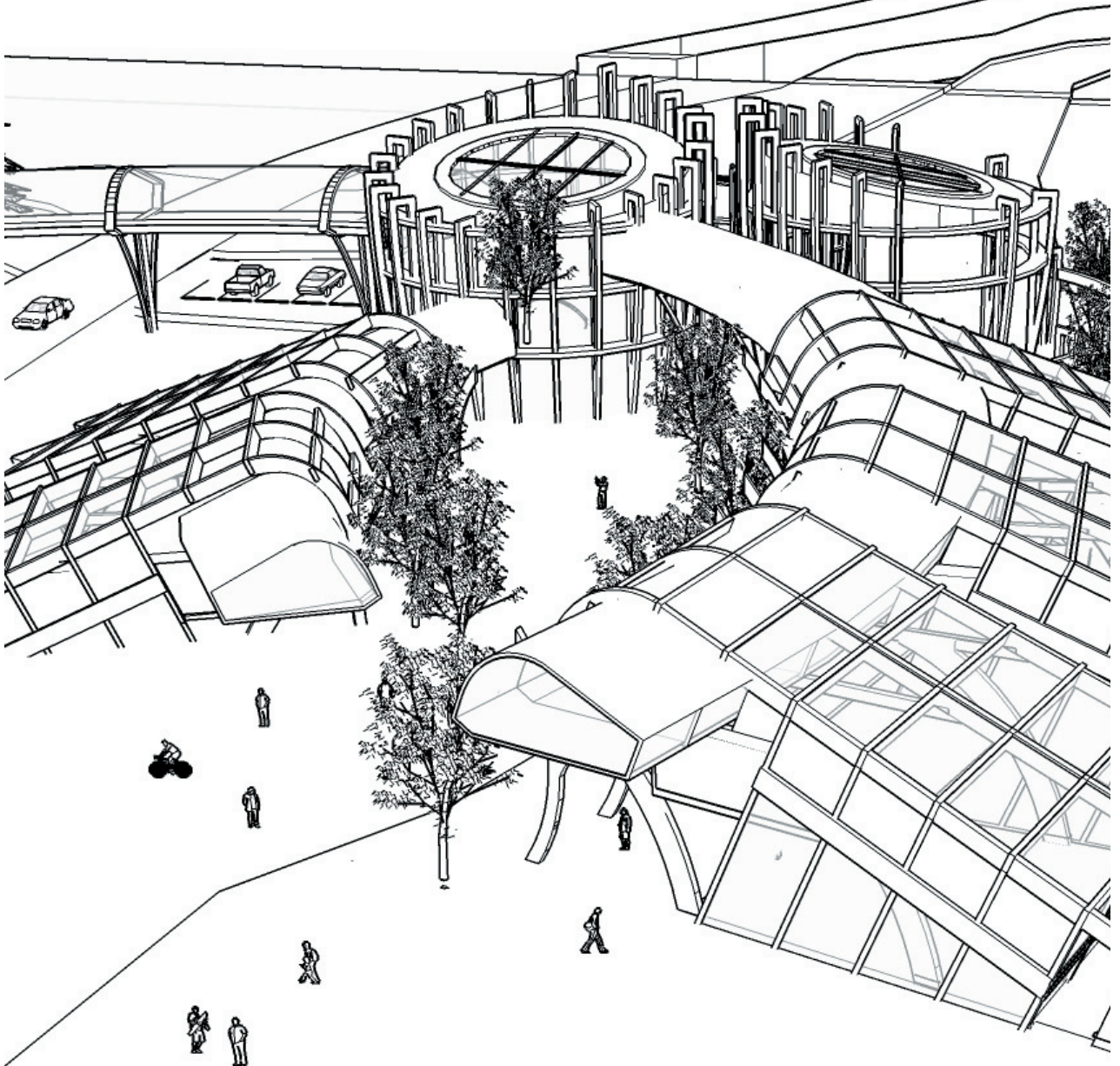

Megan Prescott

# CREATIVE SYNERGY

A design thesis submitted to the  
Department of Architecture and Landscape Architecture  
of North Dakota State University

By:

MEGAN LYNN PRESCOTT

In Partial Fulfillment of the Requirements  
for the Degree of  
Bachelor of Architecture

---

Primary Thesis Critic: Cindy Urness

---

Thesis Committee Chair: Don Faulkner

MAY 2006  
FARGO, NORTH DAKOTA



# CREATIVE SYNERGY

An art community in Alexandria, Minnesota for young people.

## STATEMENT OF INTENT

### THEORETICAL PREMISE:

This project will examine the benefits of a community centered on and around art making. The examination will look to the historical premise of art communities to establish an influence. It will also determine the influence such a community will have on the individual artist.

### PROJECT JUSTIFICATION:

This project will illustrate how a young person's awareness of civic culture can be influenced by a shared aesthetic design.

### THE PLAN:

To produce an environment filled with areas where the individuals in the art community itself and the surrounding area can come together. By providing such spaces the whole will become greater than the sum of the individual parts; synergy. This project examines the possibilities of a community setting to propel creation in individual artists, and the community as a whole.

By creating a mix of large public spaces the small private spaces, the built environment is not the only designed element. The small spaces between the buildings becomes just as important, if not more, than the built environment.

I want the spaces I create to be built inhabitable pieces of art themselves, architecture as art. When designing an art center the designer is given more freedom with form, therefore the forms I will create will reflect this. At the same time I want the materials for the structures to remain organic.

 Närrätive

Art is eternal; it can be viewed for years after its original creation and still be appreciated. I would like to create a center, a community of sorts, to support the arts. In this facility there would be an environment for people to experience arts of all kinds, visual, performance and literary. This center would provide students of the with an environment to pursue their artistic endeavors. This community would be self generating by providing art related services to the community. The students would be able to live, work and learn in one facility.

The center's master plan would a campus style arrangement. The site I've chosen is beautiful with natural elements nestled on a lake side in central Minnesota, broken into two sites separated by a road. The lake side would feature all the public elements that the students would use and provide, including the theater and various classrooms etc. The side opposite is more wooded and would provide the student's living environment. It would be my intention to keep as much of the natural vegetation as possible, therefore the living arrangements would be broken into small living quarters, sprinkled among the vegetation, elevated among the trees.

This institute would bloom in the community I have chosen. Alexandria, Minnesota's population triples in the summer months. It is heavily populated by vacationers from the metropolitan area that would be willing to experience art from the local art institute. The location I have selected is surrounded by lakes, and along these shorelines are cabins that are full through out the summer. The program would also be successful because the students would be able to support the program by selling their art to the public. In a country where school funding for the arts is decreasing, this community would not let art cease, but continue to thrive.

The visual arts students would be able to teach art classes to the youth to pass on their passion to the next generation. Performance arts would be able to generate funds while putting on plays, movie productions and teaching the

art of dance, theater and film study to all those interested in the community. Literary scholars would find fulfillment through discussion groups. The compound would also be a model for sustainability, by using as much naturally produced power as possible.

My goal for this project is to provide and environment for artists to explore a world surrounded by their artistic peers that support and push one another in a direction that is hard to achieve on one's own. I would like this community to be the beginning of something great, a new idea. I would hope these environments would spread throughout the country forming a network for new artists. My hope is to network theses environments to form a large international community

user and client



## user information

The individuals that would live in this community would be students of the arts. I want to encourage young people to chase the idea of being an artist, instead of giving in to the stereotype of starving artist. Every age type would be welcomed for the community classes.

## ownership

There are several options for the ownership of an art institute. An individual or group of art supporters could start the project and raise the funds and anything else needed to begin. Matched funding from the state of Minnesota, could also be an addition and would add to the funds from the art enthusiasts. Another option would involve the public school system, money could also be raised from this direction and add to the capital for the project.

## user groups

The user groups would consist of the individuals living at the center and those in the community and region that partake in the events held there.

This project is unique because of the possible switch in activities depending on the season. In the summer months I envision the institute as a place for young individuals that want to expand their skills and pass them on to others.

In the winter the atmosphere could change, it will still be focused on art making, but for a different cliental. It could provide an environment for artists later in their career to get away and get back to their art making,

which could be painting, writing, etc. These individuals could include college professors on sabbatical, any artists that needs to get away to pursue their passion, or elder hostel travelers.

The number of individuals living at the institute will range from 30 to 50. This is my estimate at this time. This number may be adjusted after researching the area needed for the individual activities.

The peak usage will occur during the weekends in the summer or when there are shows or performances.



The major parking concerns are related to visitors from the community. They will need spaces that are easily accessible. The inhabitants of the community will also need parking but it will not need to be as convenient because they will not need to be coming and going as frequently.

The physical restrictions are the same as that of any other public area. The community side of the project will pay special attention to the needs of everyone. The living environment will have the appropriate number of units available to those with physical restrictions.

The only major medical aspects that need to be taken into account are general well being for all of the spaces. Proper ventilation, heating and cooling will need to be maintained in all of the work areas to ensure the health of its inhabitants.

# major project elements



## Living areas

Housing Side: 200 sq ft. Small Individual buildings: each unit is designed for two individuals. The two person units are combined into groups of three, to form six person units. These six person units can be grouped with other six person units to form larger communities.

South Community Building: 8400 sq ft. Where group meals could be eaten or gatherings for all the artists living within the community. The upper two floors in this space are converted from lounge space in the summer to sleeping space in the winter when there are less inhabitants in the center.

3 bathhouses: 865 sq ft. These buildings are spaced among the residential units to provide access to showers, bathrooms and laundry facilities. I concentrated the plumbing in these units due to the fact that the small residential units would be closed half of the year.

Pavilions: 1335 sq ft and 865 sq ft. 2 large open air pavilions are placed on the residential side to allow further community development through interaction and gathering for meals and social events.

The bridge: Extending from the South Community building to the North Community Building, the bridge allows for safe transit from one side of the site to the other. This connection space also acts as a defining element for the center.

## community area

Theatre: 2500 sq ft. Outdoor open air stage that could be used for theater performance or an area to project films made at the institute, with landscaped outdoor seating.

The theater students could use the theatre or any of the indoor gathering spaces to practice and produce their plays.

North Community Building: 8400 sq ft. Acts much like the South Community Building, as a gathering space for the artists.

Studios: 2200sq ft All studios must contain sinks, good lighting and views and plenty of storage. These spaces must remain open to different art forms and events that will need to take place in them in the future. There are no permanent walls within the studio spaces, except for the rest room walls. This allows the spaces to be configured, through moveable walls, to the activity that the space is being used for.

Gallery/Connection Spaces: These areas connect the studio spaces with the community building. As visitors enter the community building they are directed to these spaces, once inside they can not only experience the artwork created by the artists but also the spaces in which the art is created. This interaction is illustrated through windows running the whole length of the gallery where it meets the studios.

Community Classrooms: 1800 sq ft. These areas are smaller versions of the studios. Placed on the north side of the community area they are closest to the road, and are therefore more public which is ideal for the purpose. They provide the space needed for the community education programs.

Offices: 3435 sq ft. The office space is where the organization happens at the center. Here the scheduling of speakers, bookkeeping etc happens.

# ■ site INFORMATION

## Location

West Central Minnesota  
Alexandria, MN  
Along the shore of Lake L'Homme Dieu

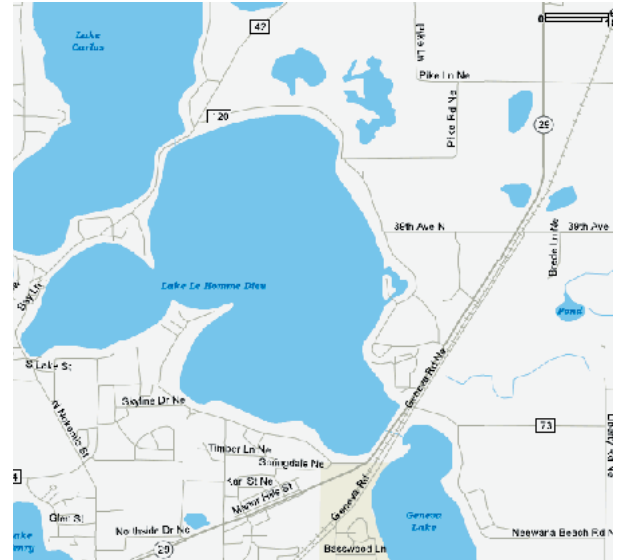

## Living areas

The site I have chosen is important because of its natural beauty. This will allow the artists to be inspired. It also provides a beautiful setting to experience art in nature and to appreciate its forms. The part I find most special about this site is hard to explain in words. Growing up in the area we would go for drives to look at the beautiful houses along the lake. This part of the area was always the most special for me. I often wondered who lived in the houses, and how they were lucky enough to live in such a special place; it's beautiful and would be a never ending environment for creative stimulant.

I choose this site not only for its aesthetic qualities but also for its functionality. The lake side of the road that divides the site is nice and flat, a clear view straight to the lake. This area would be ideal for the community end of the institute, because of its accessibility to people of all physical abilities.

About a quarter to a half mile from my site there is a public water access, I thought this

would be an excellent way for people to launch their boats and come over to enjoy one of the outdoor shows. The lake my site is on is nestled in a large chain of lakes that includes other options similar to this, a restaurant and a resort offer the same drive up service. An individual could make a whole day just boating around to different attractions in the area.

In the other direction on the same road there is another community of the same nature, Theatre L'homme Dieu. This theatre houses students from St. Cloud State University. These students live and produce plays on site. My hope is that my community along with the current Theatre L'homme Dieu could come together and draw a bigger crowd that either one could alone.

The area directly across the road, is a hilly, wooded terrain. I felt this area would be best suited to be the living area for the artists.



# site INVENTORY

## views





Due to the site's location along the shore of Lake L'Homme Dieu, the integrity of the shoreline must be kept. I would like to keep the shoreline as is, not cutting away any soil. My goal will be to preserve and maintain the natural shoreline, water quality and to protect the watershed. Careful attention must be paid to the hydrology of the site and in what direction waste water will flow, keeping it from contaminating the beautiful lake.

Alexandria lies in the Deciduous Forest region in Minnesota, near the Prairie Grassland area. Sugar Maple, Basswood, various Oak types, Ironwood, Elm, Hickory, Butternut, Birch and Aspen are present in the Deciduous Forest region of Minnesota. My site has has a beautiful old growth of these deciduous trees, that would be maintained and cherished in my project.

The landforms and lakes in the Alexandria area were created from glaciers, these glaciers also played an important role in shaping Minnesota's soil type today. The Wisconsin Glacier was the most recent, 75,000 years ago, it's lobes (tongues of ice) formed the lakes that we see today. The Wadena Lobe in it's last movement created the Alexandria moraine. A moraine is an accumulation of boulders, stones, or other debris carried and deposited by a glacier (dictionary.com). This lobe was also responsible for creating the Itasca moraine, and the drumlin fields spanning Otter Tail, Wadena and Todd counties.

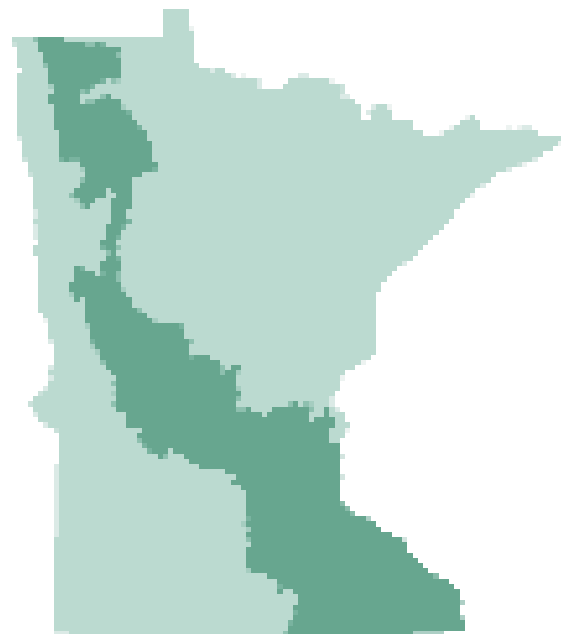
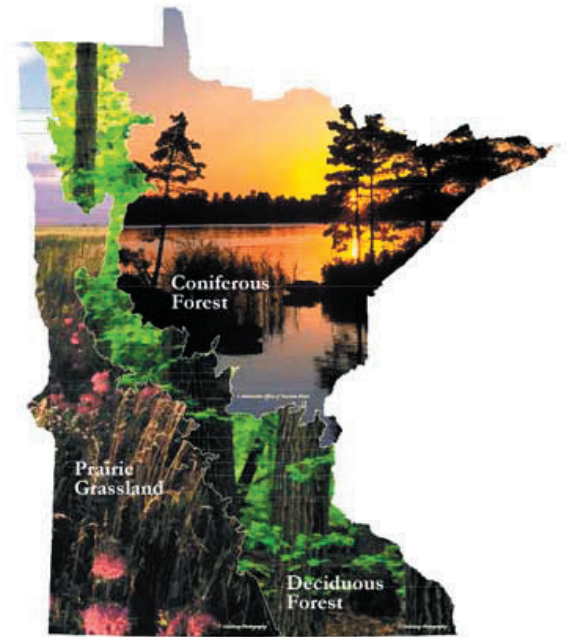

■ project emphasis

## Theoretical premises emphasized

My emphasis for this project will be based on my examination into the historical premise of art communities centered on and around art making. I hope to fully discover all the benefits that an individual receives living in a community centered on and around art making. During this examination I hope to discover all the connections art communities have made in the past, so that the community I create can do the same. From these discoveries I hope to extrapolate art metaphors that will aid in my design.

 a plan for proceeding



## DEFINITION OF RESEARCH DIRECTION

Research and analysis will be Mixed Method, combining Quantitative and Qualitative approach. The Theoretical Premise will guide the concurrent transformative strategy. Both qualitative and quantitative data will be collected simultaneously. Priority will be set by the theoretical premises which includes historic case studies. These case studies will illustrate design principles to be analyzed. Integration of the research will occur through the research and design implementing throughout. Analyzing and interpreting will also occur through the design process, ensuring the most useful knowledge is maintained.

The Qualitative data will come from statistical data, and other reliable sources. These may be obtained directly in the field working with individuals related to the subject or collected from archives. Scientific data will also be collected using instruments or through archival searches.

The Quantitative data will be collected from direct observation of the site, area and other communities of the same nature. This data will also be collected through direct contact with people in the area around the site, or those related to the field of interest, through interviews. Archival searches will also handle some of the research for quantitative data.



Two types of design Methodology:

**Graphic Analysis:** This will be explored heavily using software, i.e. Adobe Photoshop and Illustrator.

Through the use of these programs the relations between the spaces will be discovered by using such design analysis techniques like Venn Diagrams. This will make it possible to determine where each activity is to take place in relation to another.

**Language Based:**

Philosophical knowledge will be used to examine inductive and deductive reasoning. From these methods knowledge will be brought forward as an argument or drawn from previous conclusions.

Logic and a keen common sense of the environment will also be implemented in the development of the design and its process.

**Documentation of the Design Process:**

Regular records of the design process will be made through use of sketches and electronic models. These images will be either scanned or digital drawn for further use and examination.



# schedule of work

## Fall Semester 2005

- R 27 Oct Last Day of AR 561
- T Nov 1 Portfolio InDesign Project Due
- W Nov 2 Christine's 10th B-Day
- Sat Nov 5 St. Cloud with Mom
- \*Revisit Site \*Site Analysis
- F 11 Nov Veteran's Holiday
- \*Case Studies \* Program Req
- Sat 12 Nov Thanksgiving/Mark's B-Day
- T 15 Nov Mark's 25th B-day
- R 17 Nov Community Volunteer Paper
- M-F 14-18 Nov Final Week 571
- W 23 Nov Draft Thesis Program Due
- R-F 24-25 Nov Thanksgiving
- W Nov 30 Mythology Report
- R Dec 1 Ethics Paper Due- Pro Prac
- R 8 Dec Final Thesis Program Due
- F 9 Dec Last Day Classes
- M-F 12-16 Dec Final Exams
- T 13 Dec Mythology Final
- Christmas Break
- \*Schematic Sketches \*Information Gathering
- Sun Dec 19 Christmas with Schmidts
- \*Site Model
- T-F Jan 3-6 Ski Trip Lutzen

## Spring Semester 2006

- T 10 Jan Classes Begin
- \*Plans \*3D Modeling
- M 16 Jan Martin Luther King, Jr. Day
- \*Perspectives \*Models
- M 30 Jan Graduation Application Due
- \*Gather info for Reviews
- M 20 Feb President's Day
- \*Board Layouts
- M-F 6-10 Mar Mid Sem Thesis Reviews
- \*Finalizing
- M-F 13-17 Mar Spring Break
- F 24 Mar Carrie's B-day
- \*Start Placing in Boards
- Sun 26 Mar Alicia's B-day
- F-M 14-17 Apr Easter Holiday
- \*Boards
- F 21 Apr Bud's B-Day
- \*Plot
- M 24 Apr Thesis Projects Due at 4:30 5th Floor Downtown
- T-W 25-26 Apr Thesis Exhibit
- R-R 27 Apr - Final Thesis Reviews 4 May
- F 28 Apr Draft of Thesis Program Due
- F 5 May Last Day of Classes
- M-F 8-12 May Final Exams
- R 11 May Final Thesis Document 4:30 in the Dept Office
- F 12 May Commencement at 5pm Fargo Dome

previous studio experience

## 2ND YEAR

Fall Semester:

Professor Milt Yergens:

Our studies were centered around making space. We developed spaces within walls, pavilions and bistros.

Spring Semester:

Professor Bakr Alyahmmed

In this studio we produced a project made out of alternative building materials, straw bails, for a Habitat for Humanity Project.

I also developed a 12 story, hotel and commercial use project for the NDSU campus.

## 3RD YEAR

Fall Semester:

Professor Steve Martens

Form developed around structure was the emphasis for this studio. We developed a Inuit school and a community center.

Spring Semester:

Professor Vince Hatlen

This studio continued on with structural aspects of design. In this studio I design a residential structure and a Montessori school.

## 4th year

Fall Semester:

Professor Jankinson

This studio was centered around Urban design we developed many urban spaces and researched some existing. Our final project consisted of a joint effort with the Landscape Architecture Students.

Spring Semester:

Professor Mark Barnhouse

This studio was mainly devoted to a high rise project in San Francisco. We spent a large part of the semester on this rewarding project. We finished the semester with a smaller project very near to our downtown campus. This school project involved an addition to a historical building.

## 5th year

Fall Semester:

Professor Ganpat Mahalingham

Digital media is the emphasis of this design studio. We are encouraged to use all forms of digital representation in form making. This studio also looks at form making from different aspects rather than just aesthetics. Forms are generated through the structure, acoustic and cones of vision along with other methods.

Theoretical premise research



Sociology is a "social science on the study of the social lives of people, groups, and societies, sometimes defined as the study of social interactions ("Sociology".)"

Sociology is heavily related to my project. The social interactions that will take place within my art center are the keystone that will make my project successful. This interaction plays an important role in the community nature of art production, one of the main ideas in my theoretical premise. By examining how groups relate to one another I am able to determine the positive affects such a group learning environment will produce.

My living art center will fall under the category of social organization or social institute. These terms refer to an organized group of individuals. It will fall more closely under the category of social organizations, which are social entities that have members, resources, structures etc. An institution, on the other hand, is more closely related to ideas about the correctness of an activity to regard that activity as correct or legitimate ([http://en.wikipedia.org/wiki/Social\\_institution](http://en.wikipedia.org/wiki/Social_institution).) To a certain degree my center will be an institute, in that certain techniques in art production will be taught. But I would like to avoid all issues of "correctness" because, in art, there is no right and wrong answers.

My art center will be a place where artists will be free to explore all that the art world has to offer. I would like the environment to be free of all preconceived notions towards one another, so that the experience will create an environment full of process and progress, free of harsh judgments. Such a free interaction between fellow artists will indeed produce great works that stretch the boundaries of traditional art while being transmittable to many. The sociology of the society that will be created will truly be the work of art for the center.

Anthropology is defined as the study of humankind. Its emphasis lies with all humans across the globe at all times within our existence. Anthropology deals with all the dimensions that humanity possesses ("Anthropology".)

The study of Anthropology relates to the affects such an art community could potentially have on the world, if I could so bold. The community nature that I intend to create will not be static; I plan to spread the idea not just of art communities but of an art society. Such communities already exist within our world, so if we could just find a way to connect these communities in a way that allows the free sharing of ideas, the communities as individuals would be even more successful.

Art has an ability to reach people from all over the globe. Art doesn't need to be translated, because it speaks a language of its own. Therefore people from every corner of the world are able to be affected by a good piece of art. With this potential ability to reach people everywhere, an art center that has a good network, can potentially change the way the world experiences art. This is a global look at the relationship between Anthropology and the potential of a networked art community.

The art community I intend to create will not only create a global study of Anthropology. This is another smaller scale that can be examined, cultural anthropology. My art community will not only be an open site for art creation but also a mini-culture. This culture will be beneficial in its ability to submerge the artist in an environment centered on the creation of arts.

Determinism is the philosophical idea that every situation or event, including human mental processes and action, is causally determined by an unbroken chain of prior occurrences ("Determinism"). I think it relates to ones destiny that they are brought to because of what they have done to bring them there. With determinism there is no belief in random occurrences or miracles, everything happens for a reason. Although I am new to the term determinism, the concept is quite relevant and understandable to me, although I still believe in miracles.

I think determinism can relate to art and art making. If everything happens for a reason because of the prior events that brought us here, couldn't we look at everyday as fulfilling a piece of our destiny? Therefore the individuals that come to my art center are destined to be there, and everything they create or do there they have been working up to until that point. And what they accomplish there will eventually lead to what they will accomplish. This is exactly what I want my center to be.

Determinism is an amazing revelation, it makes me feel much more important, that everyday is a piece of my destiny. It's also a little bit daunting, what I'm doing right now is leading to my future destiny? Although I just learned the term there has definitely been a sense of determinism within myself for many years, I call it fate. I have faith that I will be led where I'm suppose to be, in a way it's a comfort that I don't have to know everything about everything in this crazy world.

All human knowledge comes from the senses and from experience this is the philosophical idea known as Empiricism. This idea denies that humans are born with a certain set of ideas that will determine how they perceive the world ("Empiricism".)

Artists' experience of the world is what leads them to their art making style. Everything they have experience in their lives adds to their pool of abilities. This pooling of ideas into one community will be beneficial to all involved.

Empiricism believes in human knowledge coming from the senses which lead to our experiences. Art making of all kinds deals with the senses. Isn't a good writer one that can describe these very senses so that the reader can experience them? A potter must touch and feel the clay between their fingers and know when the thickness is just right. A painter and drawer must experience the shape of everything around them if they want to full recreate it upon a canvas or paper. A dancer or performance artist must hear the music or rhythm to make it come to life.

These are senses that we are not fully born with. They must be honed and tuned to make each individual artist the best that they can be. My center will be a place where these individuals can refine their senses and expand their experiences so when they leave they are a more holistic artist.

Semiotics is known as the study of signs, both individually and grouped in sign systems it also includes the study of how meaning is made and understood ("Semiotics.")

To me, semiotics is the definition of art. Is art not a representation of something else? Art imitating life or life imitating art? This is a fairly common saying debating a fairly common argument. In either scenario the art in question contains some sign or message that is debatable. This very argument is what makes art so interesting.

As viewers and producers of art we are always trying to see the deeper meaning within a piece of work, we are studying the signs. This is what makes good art better, the hidden meaning, the deeper thought involved within it. One can speculate time and again what a piece of art means, but only the artist can truly tell you what their intentions were.

Hopefully architecturally my complex will invoke such debates, will life be imitating art or art imitating life? I hope the piece of architecture I create will be a piece of art in and of itself. Therefore not only the works being created within the complex, but the complex itself, will be art full of hidden meaning and contexts.

Economics is a social science that studies the production, distribution, trade and consumption of goods and services ("Economics.")

Economics is an important element in the success of art center. One of my main ideas for the center is self sufficiency, through business practices and sustainable architecture. I would like the complex to generate funds through its art production and educational programs within the community.

By generating funds within the Alexandria area the art community not only benefits itself, but also the community at large. The interaction would not only be good for the complex but also the economy of Alexandria, MN.

It would provide the community with quality goods and services, jobs and the all important tourism. Alexandria's economy, like many lake areas, is largely centered on and around tourism. There are a large number of resorts and activities that bring in tourists, and keep them coming back from year to year. My art complex would definitely add to the attractions in the area.

By producing quality art products the drive to come and see would be heightened, therefore heightening the economy of Alexandria. It may also serve as inspiration for other related companies and investors to come to the area, producing a constant economic cycle of commerce.

Physics is the science of the natural world dealing with the fundamental constituents of the universe, the forces they exert on one another, and the results produced by these forces ("Physics.")

Physics is definitely important in the spaces I create. I will have to take into account forces and how they relate to one another. These forces will include sound, loads and floor vibration. Physics relates to all the mechanical and structural aspects of my structure.

Acoustics is a branch of Physics that could definitely be of service to my project. It is important that sound does not generate from one space to another. An acoustic system like that of the STUK institute would be good to incorporate. The STUK is broken into individual theatres and within these theatres is an independent form of acoustics and also climate control. These theatres also have their own structural system entitled a "box-in-a-box." This system further enhances, along with special glass in the windows, a non-reverberating acoustical system.

Psychology is the study of the mind and behavior. I am currently enrolled in classical mythology and I can't think about psychology without thinking of the myth of Cupid and Psyche. Psyche was a beautiful young woman at the prime age for marriage, but she continued to be without a husband. Because Cupid had fallen in love with her and made it so no other man desired her. The tale goes on eventually Cupid and Psyche end up together. Their names are synonymous with Heart (Cupid) and Soul (Psyche). These two end up together because they belong together you can't have one without the other. How does this relate to architecture? Every architect that has produced fine architecture has put their heart and soul into the project to make it special. This is what I hope to develop in my complex, a sense of individualism; a piece of architecture that has never before been encountered; a piece of architecture with a sense of feeling.

On the other side of the psychological spectrum are the psychological effects of an environment on a person. In a complex where art is to be produced it's important that spaces be sensitive to a person's individuality. In every art class I've been in I've always wished I had more privacy while I'm working. And I know I'm not the only one, everyone crowds their easels to the very boundaries of the room to lessen the chance that someone will go behind and sneak a peek. I know why I do it, I don't like people to look at my work until it's finished because I don't want to be judged prematurely. It sounds strange now as I'm writing it but it's true, and that's what the psychology of spaces is about. Being an art student I have an idea how people feel within space where art is being developed. Hopefully with this knowledge a better psychological solution will be met.



# TRANSCENDENTALISM

Transcendentalism is the idea that there is an idea spiritual state that 'transcends' the physical and empirical and is only realized through a knowledgeable intuitive awareness that is conditional upon the individual ("Transcendentalism.")

I have definitely felt the feeling of Transcendentalism in my life. I've been transcended to another place, and the times I've gone to this wonderful place it has been while painting, drawing, sewing or designing in some fashion. There's someplace special and peaceful where the mind goes when it's completely being used, I love this place. It is such a retreat from my everyday hectic run around. I could see where it would be addicting and if I could I'd spent all my time there.

To be able to live in a place that helps in individual transform to this realm would be very powerful. This is what I intend to create; an environment that not only gives an individual the necessities needed to create, but a space that can actual transcend a person to a whole new level of thinking, now that enormously rewarding.

I hope that my architecture as a whole becomes transcending. But this cannot be created through concrete and steel, the import spaces are the intimate ones. The nooks and hidden spaces in our individual worlds is what allow us to be transcended. This is what I hope to establish, small pieces of design; big in impact. Art is transcending and I hope the architecture I create can assist in the magic and allow it to be discovered by individuals that haven't yet.

# ■ case studies

## de Young Art Center San Francisco, California

Located in San Francisco California the de Young Art Center, designed by Lawson Willard, takes inventive interiors to the next level. The size of the de Young Art Center is modest in comparison to other centers of the same sort, but there is nothing modest about the impact of the interior spaces.

Willard has taken an old space and reinvented it for a whole new purpose. Once a antique store, the de Young has transformed into some elegant and very useful.

As you can see from the above picture, the space was filled to the brim with old salvaged items, it took someone truly gifted to turn this space into the one you see below. The space has been changed into a beautifully lit, open, artistic space. The true ingenious in this space lies in the interior.

The space is designed in an open manner, flow from space to space is encouraged. Due to the changing nature of the program the interior spaces must be able to flow and change with the needs of the individual using the space.

The panel system that's incorporated within this space allows for such an ease of movement. This panel system abandons all notion of "wall" as permanent and unchanging. This system allows the division to move.

These "walls" hang on tracks that allow them to slide and rotate easily as the interior division of space needs to be changed. Like Japanese paper art these walls unfold, shift and transform the space.

The panel system is perfect for an art center because of the many different uses it requires. Exhibits require an open and spatially less active space, whereas performing arts and lectures require a more active use of space. Panels unfold to accommodate both large and small groups as well as activities.





## de young art center san francisco, california

These panels not only move to accommodate the needs of the space, they can also become space. Individual sliding partitions can be used for various activities as they come up. Within these panels are fold down sections to be used as work spaces and shelves stored within them ("Lawson Willard Architecture").

Pictures taken from: [www.lawsonwillard.com/deyoung.html](http://www.lawsonwillard.com/deyoung.html)

The element that I love the most about the de Young Art Center is the ingenious and adaptable use of space. By allowing the division of space to be mobile you allow the program of the structure to be flexible. As the center changes the structure can change right along with it.

I also appreciate the use of the space within the panel and tower system. A picture of the tower is shown to the right on the bottom. By allowing the "walls" to perform double duty the space becomes even more plentiful and unique. This is important if your space is limited like it is in the de Young.

One concern I would have would be the easibility. I would want the panels to move easily along the track. Maintenance would have to also be concerned with in the long run. But the benefits would definitely be worth the amount you may possibly spend on maintenance.

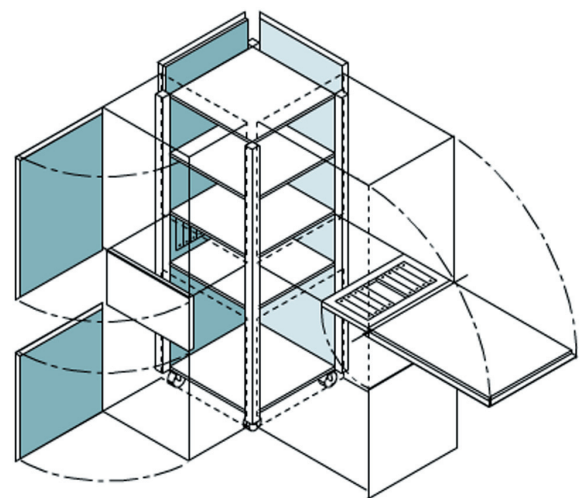

Tower Exploded Axonometric

DE YOUNG ART CENTER SAN FRANCISCO, CALIFORNIA

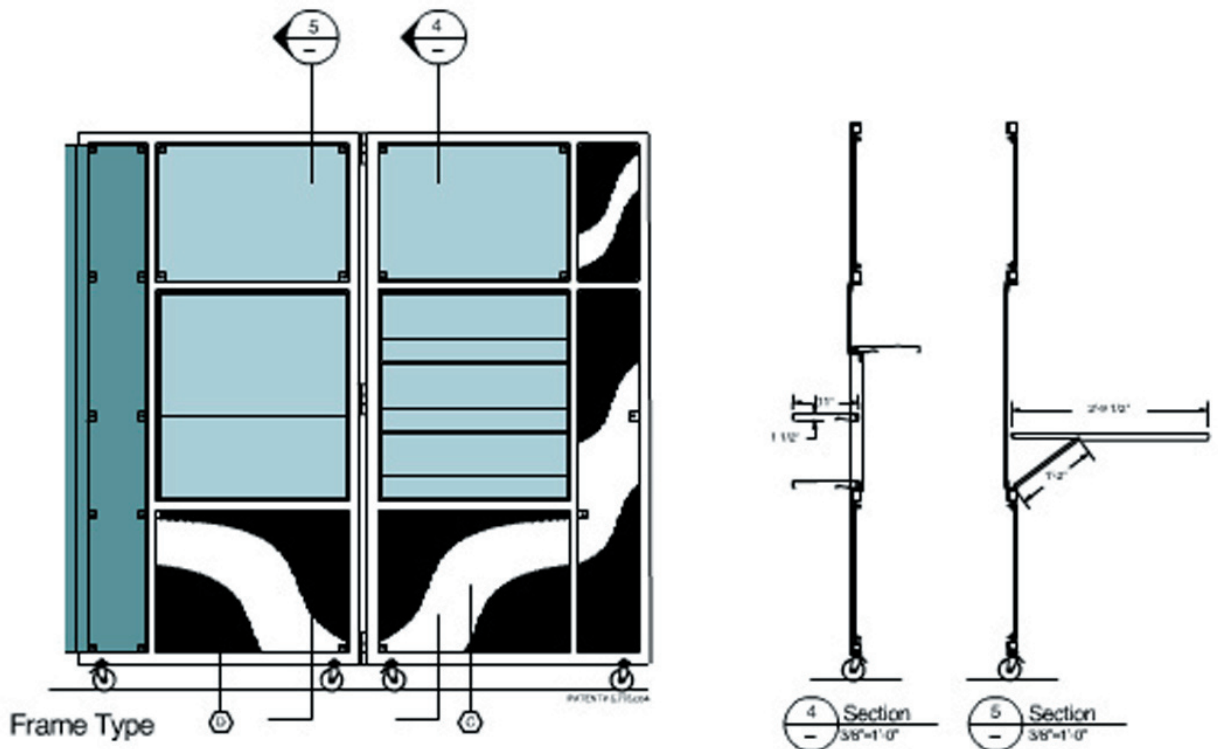
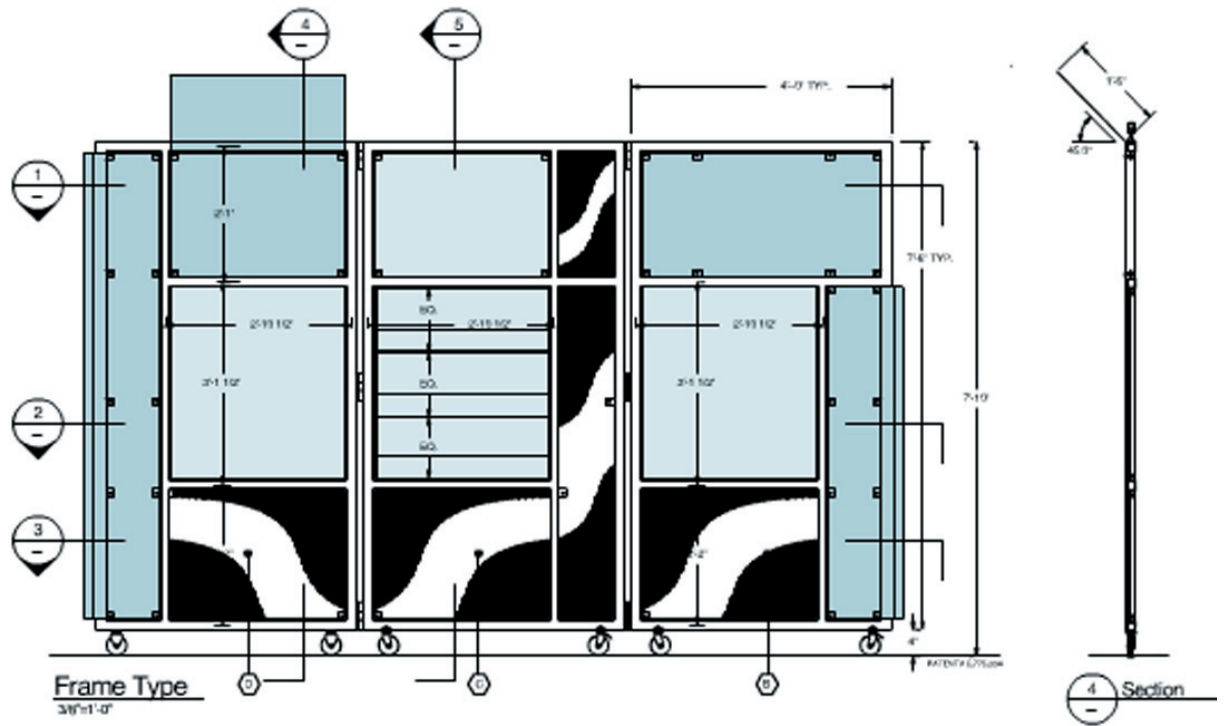



de young art center san francisco, california

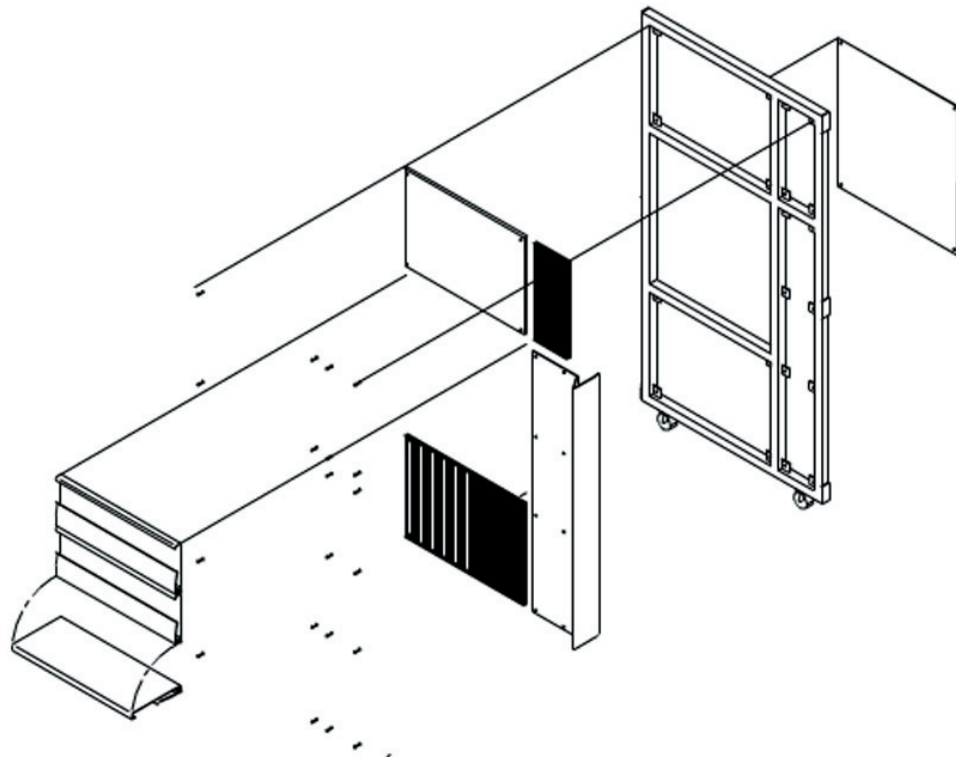
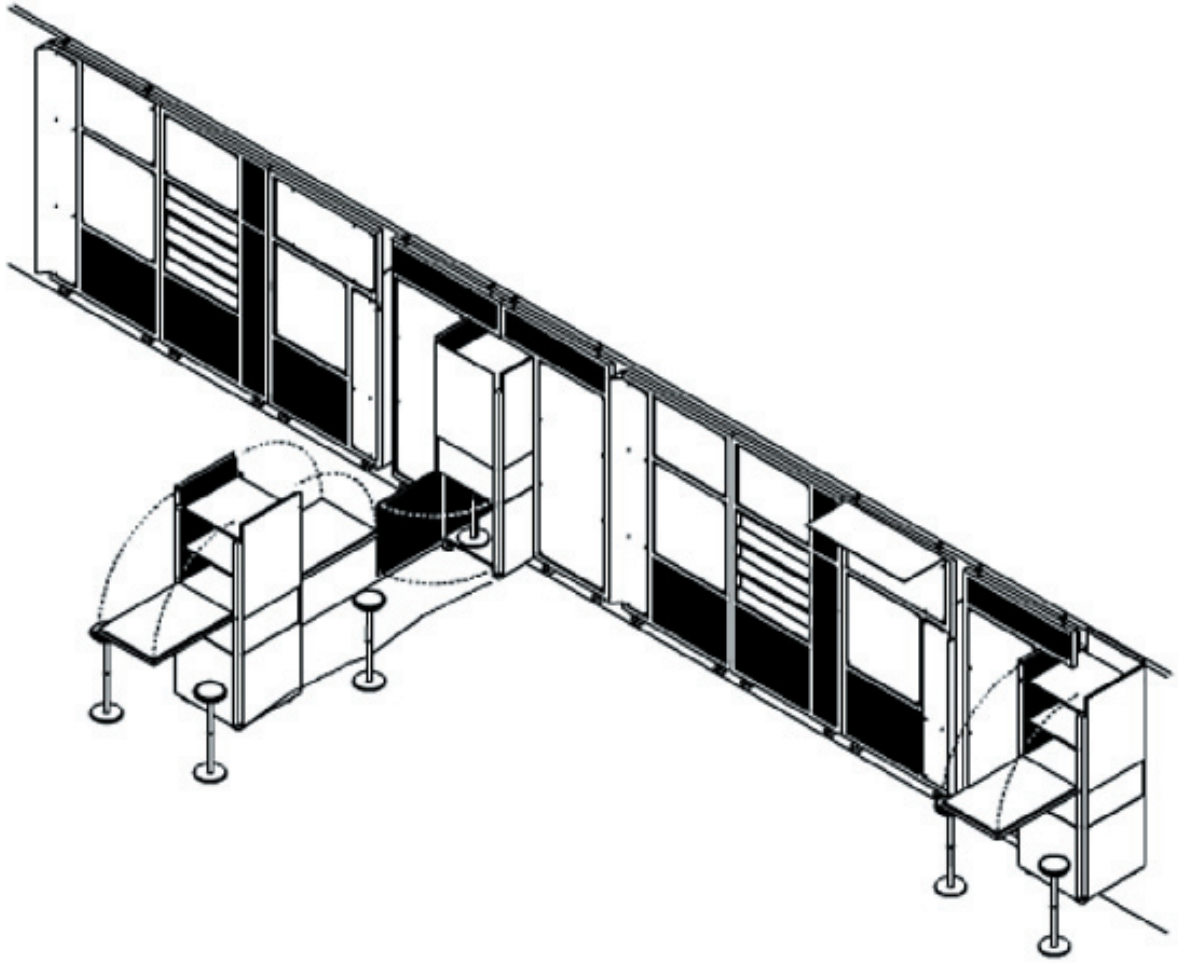

de young art center san francisco, california

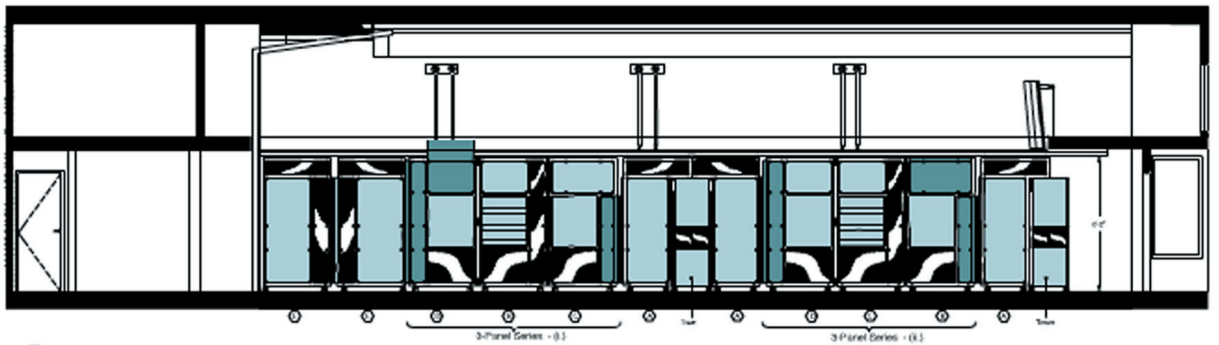
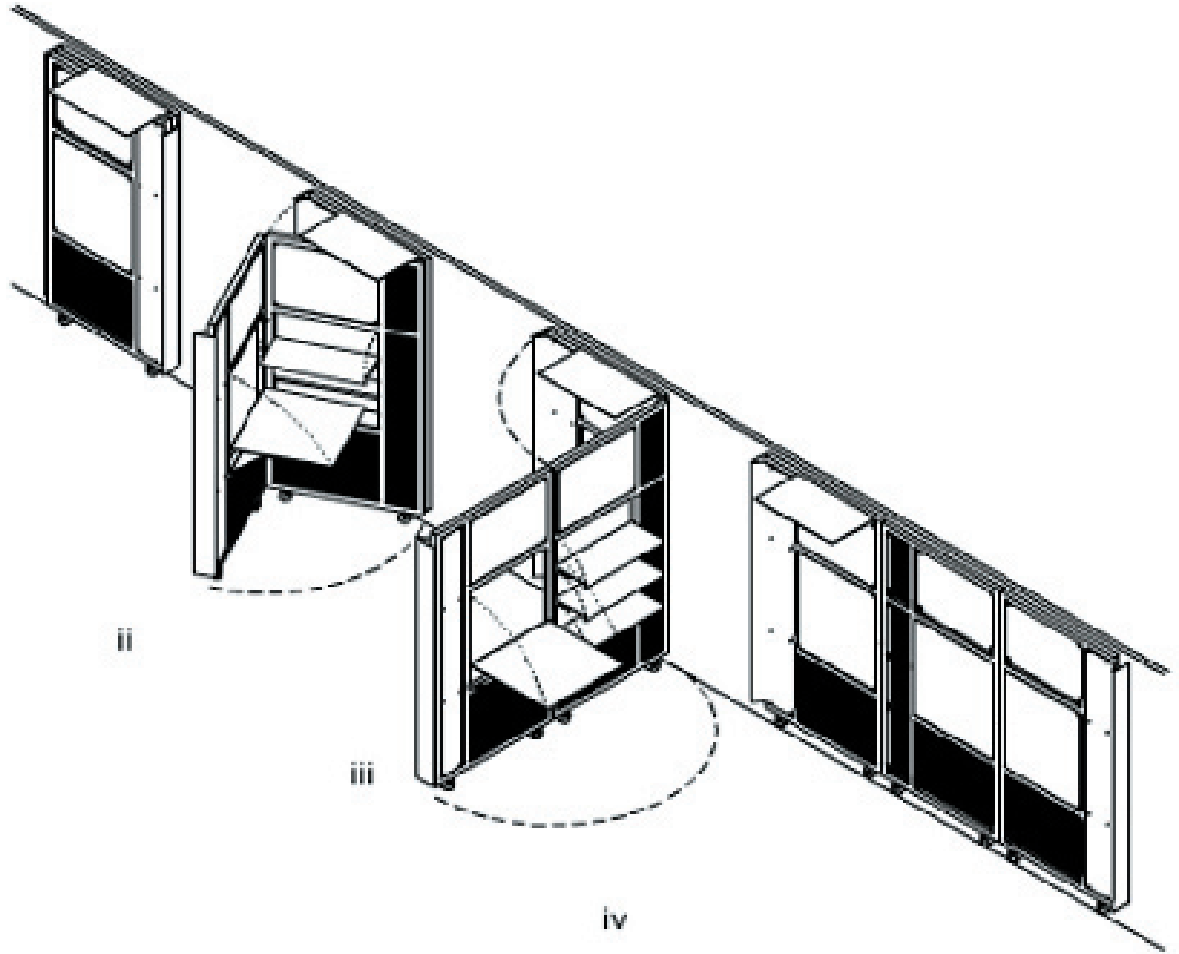

2 ELEVATION

1/8" = 1'-0"





## STUK art center Leuven, Belgium

Constructed in Leuven, Belgium, by Neutelings Riedijk Architecten the STUK Art Center is definitely one piece of Architecture that must be mentioned.

The STUK Art Center was originally part of the Arenberg Institute which housed University's Chemistry Department up until the 1970s. Only part of the institute had still be in use by the university in the past few decades.

Before taking over the Arenberg Institute entirely the STUK had been spread over all parts of Leuven. In the late 90s STUK completely took over the Arenberg Institute and began it's remodel with the help of Neutelings Riedijk.

The Arenberg institute had been made up of a string of buildings centered around an inner court. Due the vacancy of part of the Institute for some period of time many of the buildings were in need of repair.

In the beginning stages the architectures decided to deal with each wing of the complex individually, this would allow for as much of the original structure to be saved as possible. After careful consideration they decided that two wings were unusable and to be torn down and replaced by new buildings, these were to be called the middle blocks. Another two were to be given a radical make-over these were the front block and rear block. And the final two were to be given a slight face lift, the lateral wing and the auditorium. The exterior space completely revamped. On completion the art center would total 10,000 m<sup>2</sup> in area.

An entirely new special composition and internal routing were also to be put into place. The ending result of the project is a multi use space with room for the performing arts, music and the visual arts. The best part about the center is it's completely new public attraction embedded into the city's infrastructure.



# STUK ART CENTER LEUVEN, BELGIUM

## Spatial Concept:

A city with many houses.

A “variegated mosaic of different locations for performances, productions, rehearsals reception areas, courses and organization.”

Each space within the complex has character of its own. Ambience, finish, light, view and spatiality are important characteristics that the architects and planners on this project wanted to incorporate into every space. This space also has the import tie between historic spaces, new spaces and refurbishes spaces. It was important that each space was respected for it's individual character. A neutral, multifunctional complex was to be avoided. A “kaleidoscopic labyrinth of distinctive locations” was to be the goal each with its own specific possibilities for use.

## Program Elements:

10 large public theatres: Each with a specific function.

‘Soete’ theatre (dance and theatrical performances): This theatre is completely new and the heart of the complex. It has Flat-floor with a seating capacity of 220 in a fixed auditorium space. The acting area measures 14x12m and 7m high. The sidestage is 12x8m and the second sidestage has a 2m deep window which is 10m wide by 6m high. It looks like patio that can be fully opened and make it possible to perform in the theatre in daylight. This element can also be included in performance because it can be viewed from all sides of complex.

The atmosphere is futher enhanced because of the flow between the audience and the stage, not distinction is made between these two areas. The interior is punched with architectural elements like bays, balconies, loggias, gateways and windows, which adds to the view.

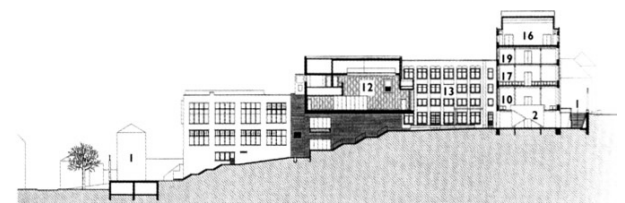
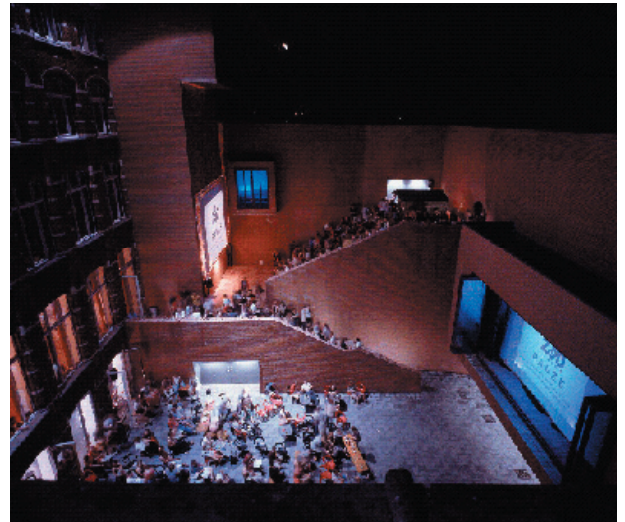

west-east long s1

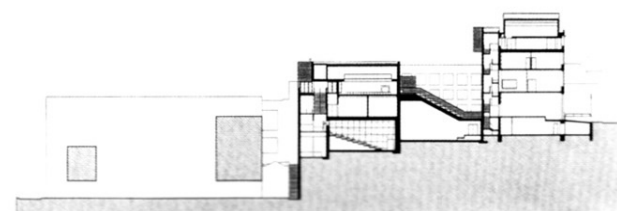



## STUK ART CENTER Leuven, Belgium

The architectural elements are further enhanced by the interior finishes. The walls are an oiled concrete zigzag pattern in bas relief accentuated with gold-colored rosettes. The floors are grey oiled ash parquet strip like "living room and an old machine factory." The chairs are a dark brown rough fabric with folding armrests that allows for conversion into sofa seating. The ceiling is made from concrete bridges, this system forms a complete roof storey, for technical equipment. Adjoining the spare are dressing rooms, technical room, various storage spaces for scenery and theatre technique.

'Labo' theatre (dance and theatrical performances)

This theatre seats 100 and 200 people, with a floor area of 20 x 15 metres. There is no fixed auditorium; layouts can be made with partitions as desired. The theatre has a fixed grid system for stage equipment at a height of approximately 5 metres.

The Studio (dance and theatrical productions)

This space is 25 x 11 metres and with its special sprung timber floor is suitable as a rehearsal space for dance and theatre productions. Try-outs and small performances can also take place here.

The Film theatre (film performances)

The film theatre is a new theatre, specifically designed for film performances. It can seat 100 people. The theatre has a steeply ascending auditorium, with fixed, large seats, considerable leg room and good sight lines.

The Ensemble theatre

(ensemble music rehearsal and small concerts)

The Ensemble theatre is a new theatre, intended for rehearsals and small concerts by the university's ensembles. The theatre measures approximately 20 x 12 metres, with a roof which ascends obliquely to a height of 8 metres. On one side the theatre is stepped, giving rise to informal seating for the audience.



# STUK ART CENTER LEUVEN, BELGIUM

The 'Paviljoenen' room

(individual music rehearsal and photography)

The Paviljoenen ('pavilions') room is a former laboratory which has been converted into a rehearsal room for individual musicians and darkrooms for photographers, for the university's use. There are five wooden pavilions for individual musicians or small groups of musicians. These rooms are sound proof; with double walls built on rubber blocks, external lights indicate whether they are in use. In between pavilions are chairs for relaxing. Towards the rear of the theater are four large darkrooms for individual or photography courses.

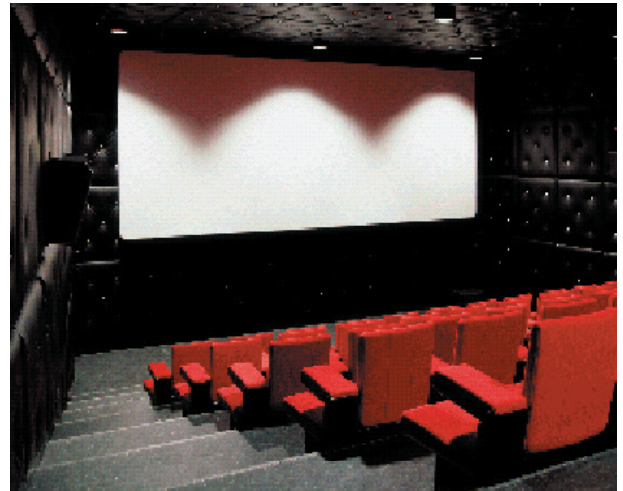

The Auditorium (lectures, talks, conferences)

The Auditorium is a relatively standard, and seats approximately 200 people

'Zuilen' room I (visual arts exhibitions),

The 'columns' is an exhibition space for visual arts, adjoined by a number of storage spaces and meeting rooms.

'Zuilen' room II (practice space cultural studies)

This room is intended for the University of Leuven's Cultural Studies course. It is also adjoined by storage and meeting spaces.

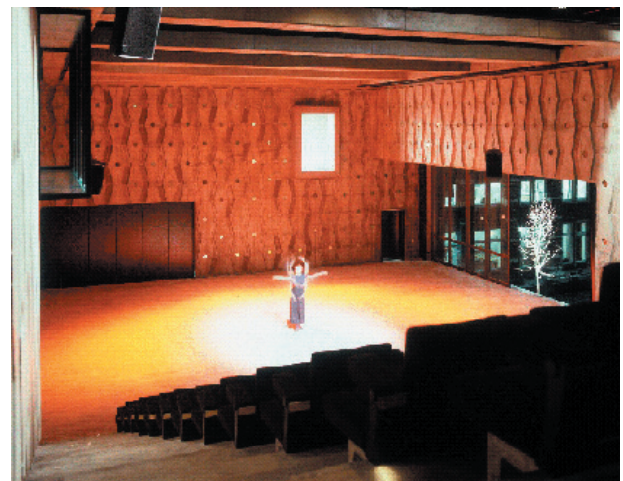

'Buiten' theatre (open-air theatre)

This outdoor theatre is on the roof of the ensemble theatre and overlooks patio. It contains an ascending auditorium that can seat 150. Evening film performances, lunch-time concerts, summer festivals and so on take place here. It also connects directly with the café's outdoor terrace. The performance area measures 5 x 10 metres and has a tall lookout tower, from where backcloths and actors can be lowered.

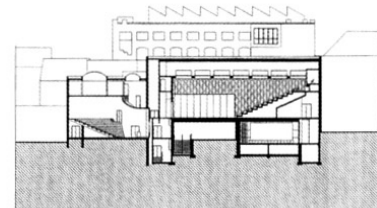

north-south cross section

In addition to the theatres:

- café restaurant
- foyer/public entrance
- rehearsal spaces- 10 x 10 x 4m high
- Offices

Green Room

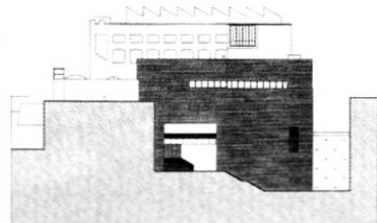



# STUK ART CENTER Leuven, Belgium

Centrally situated in the complex, under the offices and on the same level as the patio. It has a kitchen and living room for all guests, performers and assistants

## Technical Circuit

All of the rooms in the complex are connected by a technical circulation route for logistics and stage systems.

## A Public Route

Series of diverse exterior spaces.

## Parking, Bicycles, Public Transportation

## The Patio and Circulation

Intimate inner court which forms the complex's "heart and point of orientation." All the public theatres stem from this location. It is also the center for the system of public spaces that runs through the complex. These public spaces form a networks of routes that criss-cross. This encourages informal meetings between performers, audiences, students and residents of the city. There is another circuit that connects the theatre's technical spaces without crossing the public routes.

## Architectural Concept

The architects on the STUK wanted a weaving of the old and new form something new and exciting but also looked to what existed. The contrast between old and new is celebrated through a distinct set of sculptures. The rich spatial system is made up of a series of bays, lookout towers, balconies, stairways, subways, vistas, courtyards, alleyways and terraces. And most importantly a new public exterior space which has become part of city's urban fabric.

Red brick was used on the exterior of new-build the blend with the old to keep the two generations connected. Visual additions to exterior of existing are minimal, but striking providing new landmarks on each side of the complex. materials for interior, wide range: oiled concrete The rich array of materials also added to the complex and

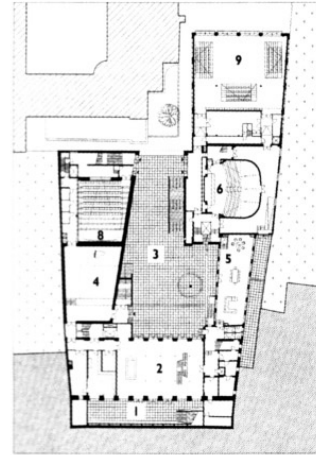

level -1 plan

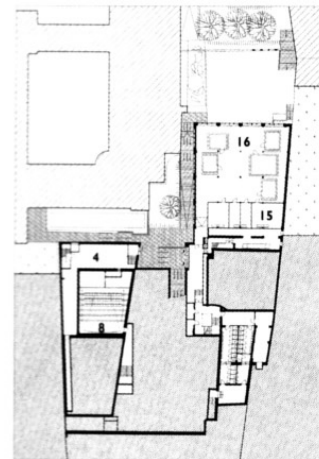

level -2 plan

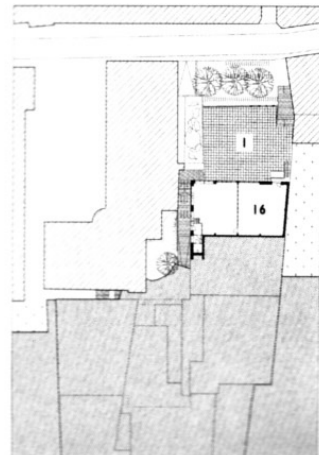

64 | level -3 plan

# STUK ART CENTER Leuven, Belgium

made each space its own. These materials included oiled concrete with zigzag pattern in bas relief, capped with brass rosettes, padded black leather walls fastened with shiny button-headed nuts, translucent slatted walls of rusty iron, masonry gold bars, black perforated shutters with red velvet filling, crates of rough wood...

The overall theme for the complex was the use of daylight, view and perspective.

Distinguishing Characteristics:

Great lengths were taken in acoustic design. The STUK uses the "box-in-box" design principle each theater has independent construction and shell foundations situated on rubber blocks, to prevent transmission of sound through the ground. Therefore all the theaters can be used at the same time. The structures are substantial so there is no noise escaping outdoors either. Windows are special heavy insulating glass so noise levels remain in legal limit. Interior acoustics are examined and measured in order to obtain from reverberation within the spaces.

Climate control was also an important issue for the STUK. Each individual theatre has its own set of climate controls with optimum ventilation and heating with the minimum amount of noise (Europaconcorsi.)

There are many aspects of the STUK that are found to be very helpful. I loved their technique for creation of a multi-use structure, allowing each space to be its own individual identity. This allowed for a wide range of material usage, and was also beneficial in the control of reverberation.

Another important factor in the STUK is the exterior spaces. These are essential for the flow of foot traffic, and beautiful in the way they connect the whole complex. This sort of system eases a person through the space and takes a large area like the STUK and makes it feel intimate. A sense of place is developed through these outdoor spaces. It also seemed important that the technical spaces been unseen, there are hidden in their outdoor transport, and in the interior spaces as well.

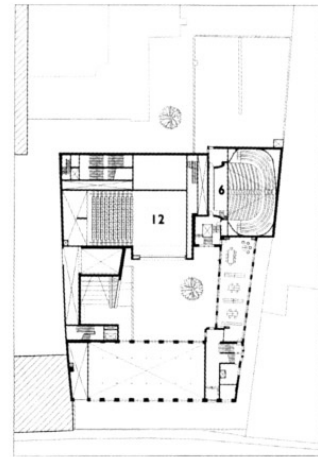

level +1 plan

- 1 forecourt
- 2 foyer
- 3 courtyard
- 4 Ensemble music studio
- 5 artistes' foyer
- 6 auditorium
- 7 outdoor foyer
- 8 film theatre
- 9 small (Kleine) theatre
- 10 café
- 11 offices
- 12 Grôte theatre
- 13 dressing rooms
- 14 technical services
- 15 photolab
- 16 rehearsal rooms/dance studio
- 17 gallery
- 18 outdoor (Buitenzaal) theatre
- 19 cultural studies room (for university)

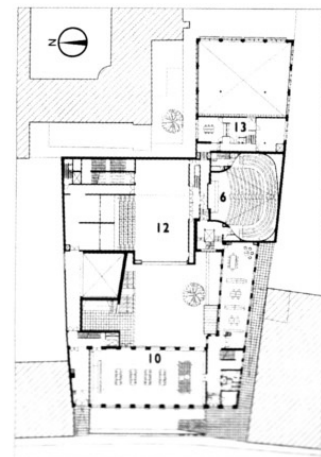

level 0 plan (scale approx. 1:1400)

# STUK ART CENTER Leuven, Belgium

I also enjoyed the play between indoor and outdoor spaces. There seems to be a nice overlap that allows inhabitants to feel outside while inside. This is accomplished through the use of lighting and views along with the beautiful outdoor spaces.

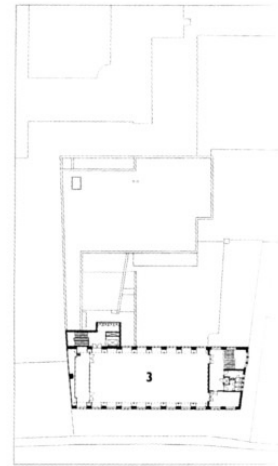

level +4 plan

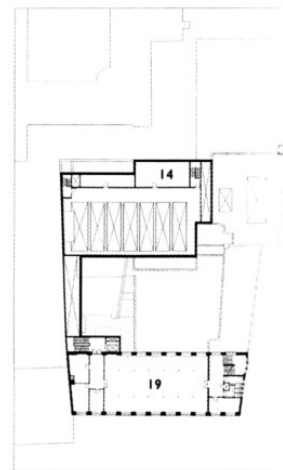

level +3 plan

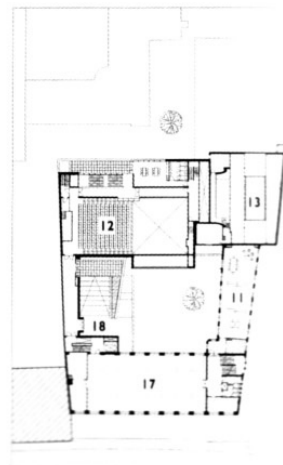

level +2 plan





# ZENTRUM PAUL KLEE

# BERNE, SWITZERLAND

Located in Berne Switzerland; Zentrum Paul Klee, an art museum dedicated to the work of Paul Klee was designed by Renzo Piano.

This museum was sponsored by Professor Maurice Muller, a surgeon who invented the artificial hip, and his wife Martha, who selected the location and the architect, and insisted that the building be a center for all the arts and for people of all ages.

This site is entered through all forms of travel: from footpaths, to city buses and motorways. This site was shifted to address the sunken motorway, mirroring its gentle curve in the glass façade and even in the lines of the vents cut into the floors of the galleries. By doing so a metaphoric bond is created between the modern world and the city.

The hilly landscape inspired the profile of the steel beams, that define this beautifully elegant piece of architecture. Each vault encloses a set of spaces that are linked at the front by a 150m glazed concourse which contains a café, ticketing area, gift shop, and a reference area.

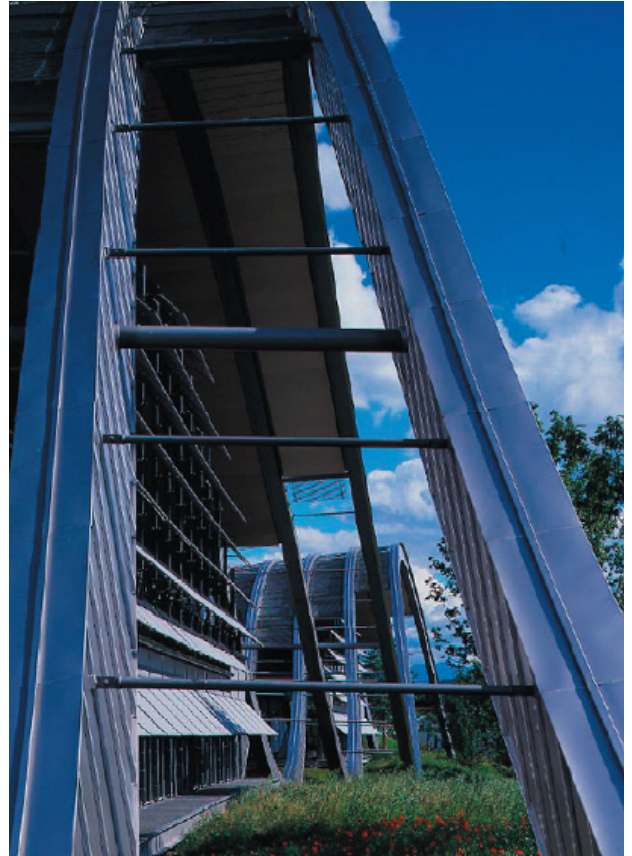



# ZENTRUM PAUL KLEE

# BERNE, SWITZERLAND

The central pavilion houses a changing selection from the permanent collection, with a exhibition gallery below. To the north are meeting and restoration areas. Included with this is a creative workshop for children below, and a subterranean auditorium behind which seats 300 people. Regular performances of chamber music, dance, and theatre take place here along with lectures and readings.

The South Pavilion houses the administrative offices, archives, and seminar rooms all on the main level.

A total 4.2 km of steel girders were cut and shaped by computer controlled machines and then the 40 km of seams were hand welded, because each section has a different configuration. Each of the arches are slightly inclined at different angles, braced by compression struts and tied to the roof plate and floor slabs. The concrete floors were constructed as a single structure, with settlement joints.

The beautiful glass façade is divided into upper and lower sections, joined at the 4m roof level of the concourse and are suspended from girders to avert stress from thermal expansion on the steel roof.





# ZENTRUM PAUL KLEE

# BERNE, SWITZERLAND

The glass is shaded by exterior mesh blinds that auto-extend in response to light intensity. This element along with the high level of insulation minimizes energy consumption.

The galleries and archive's temperature and humidity must be maintained at constant levels to keep from damaging the art work.

The permanent collection is displayed in a 1700sqm room that is divided by suspended flats creating a sequence of spaces. Each of these white screen hovers a couple of a cm above the oak floor as do the up right walls. Low level lighting is achieved through indirect and filtered light sources. Spot lights are cast their light on the white-boarded vaulted ceiling and this is diffused by suspended square scrims.

Works are displayed so they can be appreciated as individual works and don't overwhelm the viewer. This is made possible by the floating platforms and the soft light ("Monument to a Miniaturist.")



zentrum paul klee      berne, schweiz

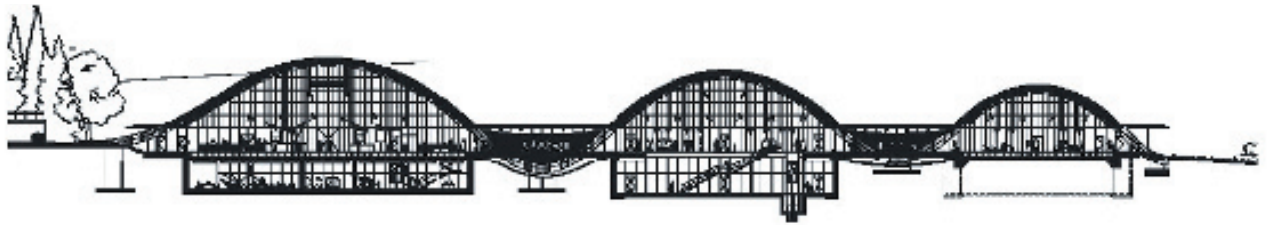
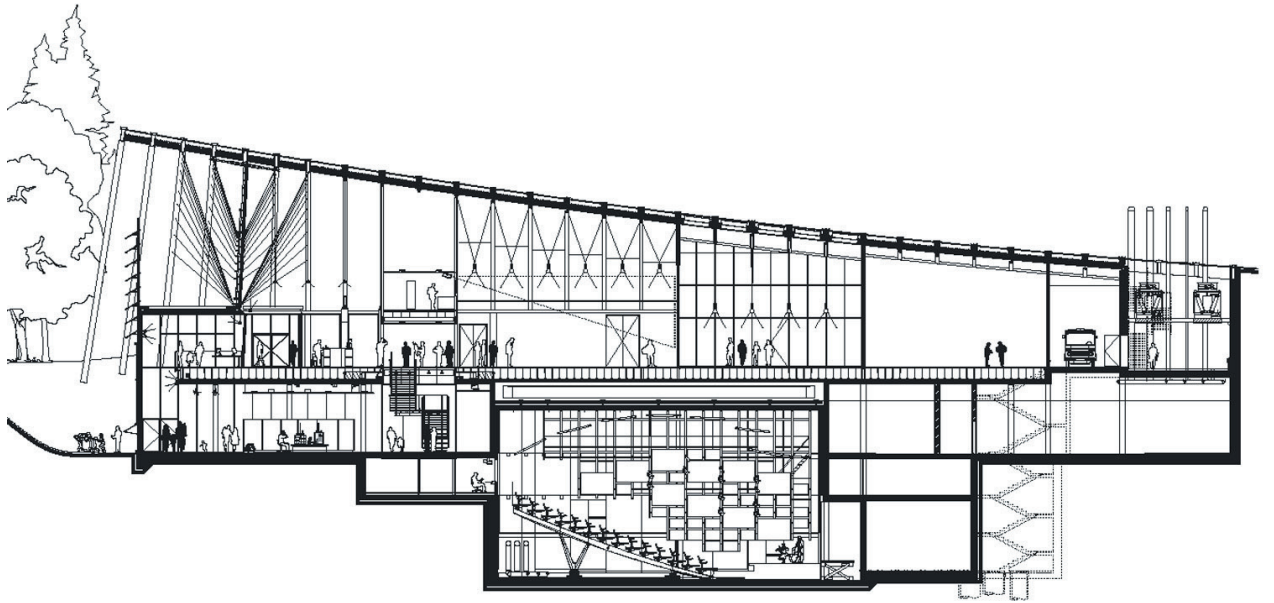

cross section

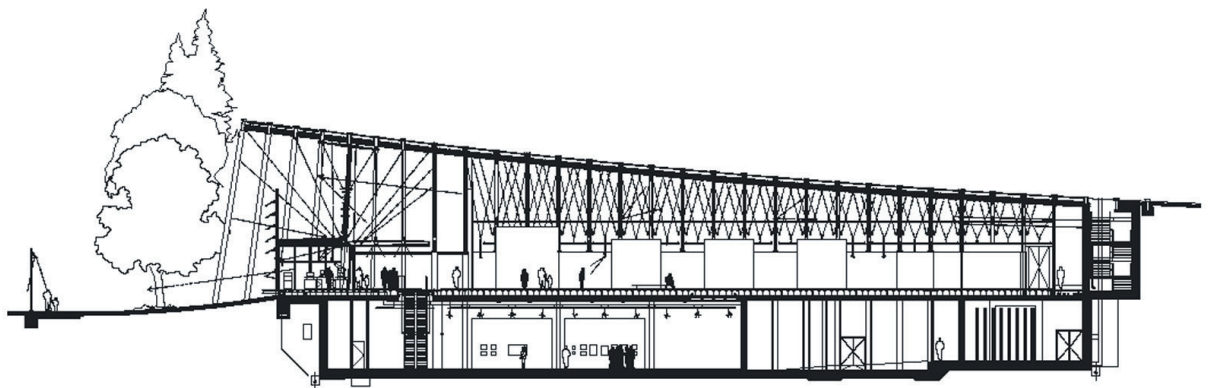

long section through middle pavilion (concourse, galleries)



# ZENTRUM PAUL KLEE

# BERNE, SWITZERLAND

There are many elements that speak to me in the Zentrum. The first and most stunning is the sweeping curves, they are beautiful and striking. They are also important because they are a response to the site's rolling hills. I also appreciate the connection between the pavilions and the concourse, the juxtaposition of the two elements not only provides aesthetic beauty, but functionality. The light glass paired with the strong steel is also a nice touch. I think this structure is a beautiful blend of metaphors and ingenious programming.

I also think this case study was also important because it cued me into some of the funding for the project, which occurred from an independent contributor.



site plan

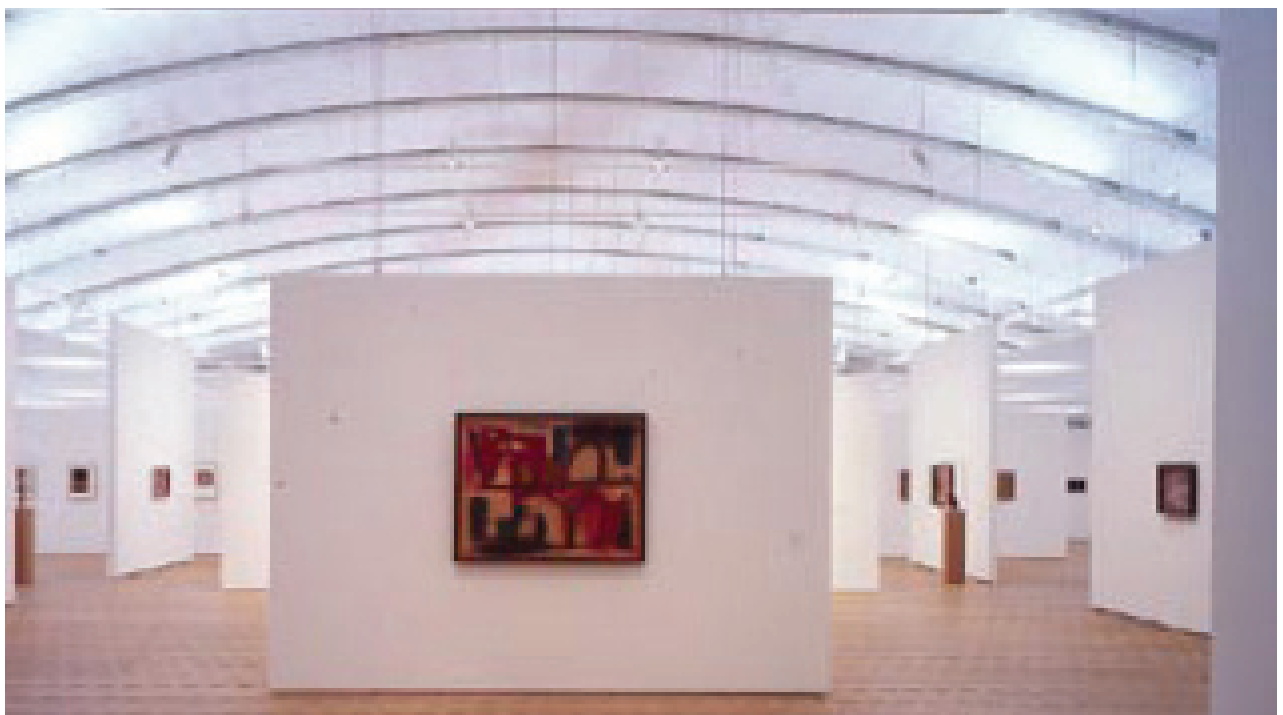

# ZENTRUM PAUL KLEE BERNE, SWITZERLAND

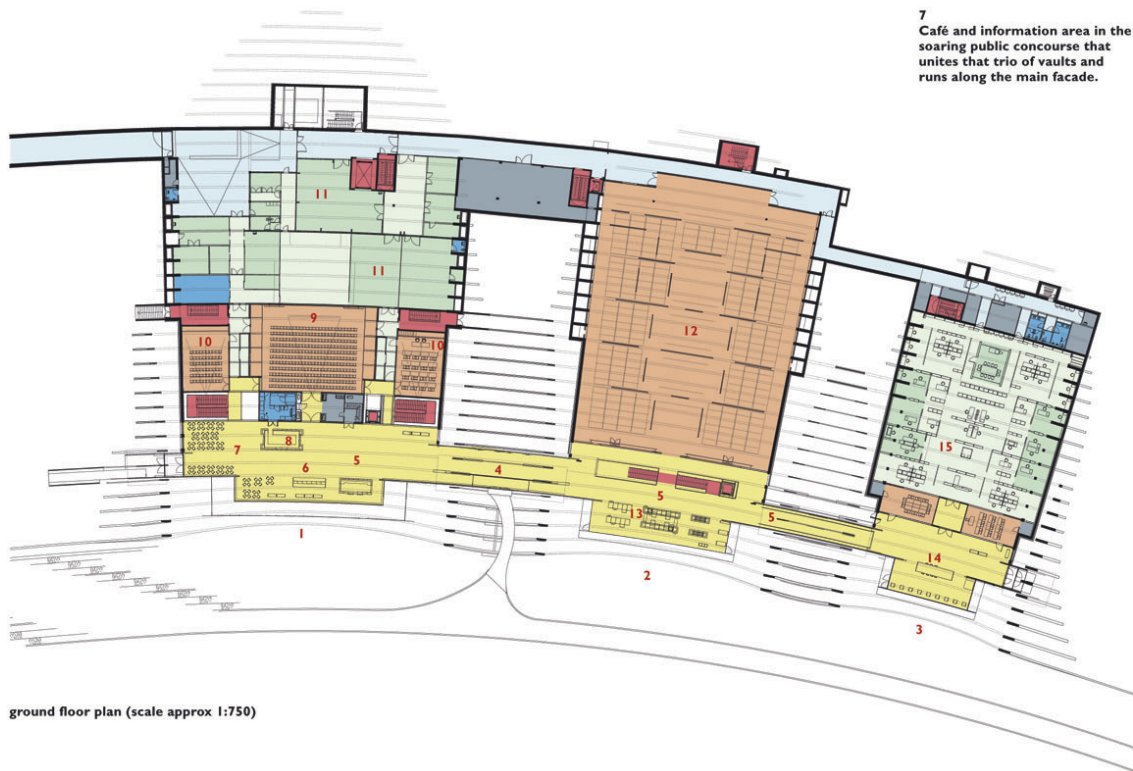

7  
Café and information area in the soaring public concourse that unites that trio of vaults and runs along the main facade.

ground floor plan (scale approx 1:750)

## ART MUSEUM, BERNE, SWITZERLAND

ARCHITECT  
RENZO PIANO

- 1 north pavilion
- 2 central pavilion
- 3 south pavilion
- 4 main entrance
- 5 concourse
- 6 information
- 7 café
- 8 servery
- 9 cinema
- 10 AV rooms
- 11 restoration workshops
- 12 permanent collection
- 13 shop
- 14 reference section
- 15 offices and administration
- 16 temporary galleries
- 17 auditorium
- 18 children's workshop

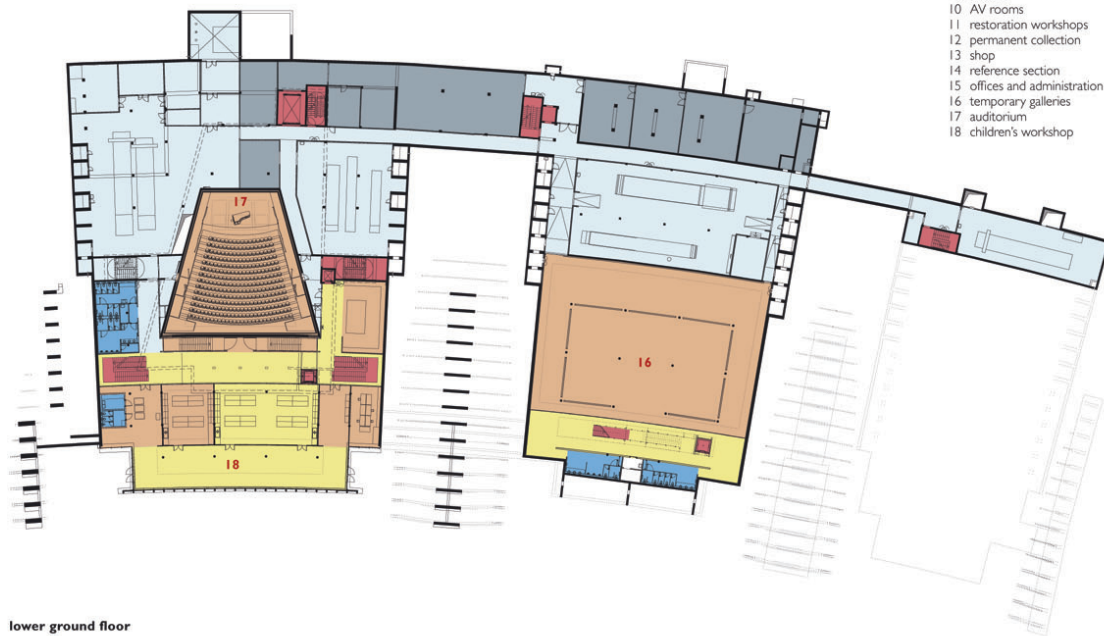



treehouses of the world, a book by pete nelson





## Treehouses of the World, a book by Pete Nelson

The North side of my site is a wooded region. I want to keep as much of that woods as possible. I think this area would be perfect for the housing end of my project. It would give the artists living there a sense of privacy and a surrounding beauty that could only benefit their artwork.

So I got to thinking what would allow this wood to remain as untouched as possible but would still allow for the housing? The answer seems to me a form of treehouse. This would allow the trees to remain, but also for structures to be built.

I stumbled upon Pete Nelson's book *Treehouses of the World* and knew these structures would be perfect for my site and program. Treehouses lend themselves to many options. They can range from the conventional, that just appear to be average structures set in the trees to whimsical like the one on the previous page. I think they would be perfect in an art community because they could all have a character of their own yet connected in their typology. There are so many options that go along with them, and who hasn't wanted to live like Ewoks from Star Wars or Swiss Family Robinson.

To the right you will see two interior shots from the treehouse shown on the previous page. As you can see they definitely have a personality of their own shaped by the natural element of the tree.



## Treehouses of the World, a book by Pete Nelson

The element I like most about this treehouse is the large deck. This would allow artist at my complex to come out and read, write, paint, draw, etc. in the clean outdoor air.





## Treehouses of the World, a book by Pete Nelson



The element in these two treehouses that I think is valuable is the entry sequence. It gives the tree houses an extra twist and that added outdoor space that would well used.

The treehouse on the left is also beautiful because of its use of traditional elements like the gable roof, mimicked by the two large windows.

The picture on the left illustrates the versatility of the treehouse as a two story structure. Pictures taken from (Nelson.)



## PERFORMING ARTS CENTRE ANNADALE ON HUDSON

The Performing Arts Centre by Frank Gehry was originally intended to be located on sacred grounds. Artist for centuries have been sketching on the banks of the Hudson near the site where this complex was to be built. After much scrutiny it was decided that the Performing Arts Centre would be built on the 540 acre campus of Bard College, located 90 miles north of New York City.

Being the first of Gehry's structures to built on a rural setting instead of the usual city site. But the structure works outside of the city as Gehry intended. As the light changes throughout the day the foil structure reflects and changes. It also serves to mirror the surroundings.

Leo Botstein wanted a complex that would reflect the university's commitment to the arts and make an ideal place for performances. This centre serves an annual summer music festival and solo performances all year round.

The program for this Performing Arts Centre is 10,760 sq meters. This includes large rehearsal rooms for drama and dance, a fully equipped black box theatre seating 250, and in addition there is a 930-seat Sosnoff Theatre which is used for orchestras, opera, dance and drama.

This complex was designed from the inside out. One problem that any designer encounters when designing performance spaces is the large amount of boxes spaces. This is the reason Gehry decided to use his "foil" system. By wrapping the boxes with the metal harshness of the rectilinear structure is covered with smooth flowing forms. These structures have made way for many designing metaphors, like the flowing of a skirt on a runway model.

This facade is not only decorative, it flows down to form the entrance space. Gehry's intention for this space was more than just an entrance, but also it would become a place where people could gather in

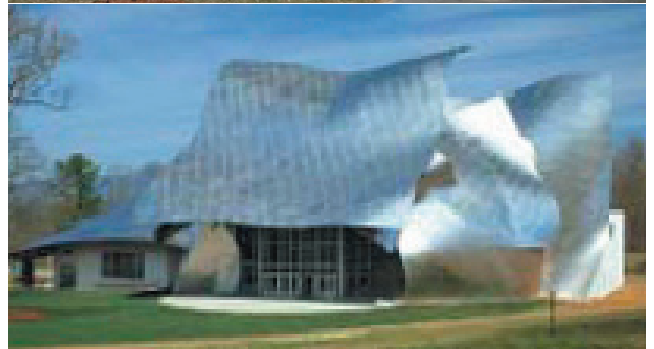

## performing arts centre annadale on hudson

anticipation for the performance they are about to see.

In the back of the centre the structural boxes are exposed, adding a further metaphor, the backstage.

Some, myself included, have issues of the architectural integrity of these foiled spaces. But be assured that there is no deception. The foil is "airborne and dynamic as a dancer on stage", and the supporting trusses and braces are left exposed.

In performing spaces, acoustics is key. Large spaces with tall open ceilings is necessary for large orchestra productions, but lowers smaller spaces is better for verbal presentations.

In Sosnoff the side walls are slightly bowed and the acid washed concrete is overlaid with spaghetti loops of fir battens to diffuse sound. Architectural elements like balconies are also used as sound reflectors. Acoustic shells and suspended ceiling panels are stored away in close proximity for use in orchestral productions. The stage is also mobile to allow for reconfiguration for different uses.

The Black Box is also able to be reconfigured and even more dramatically, with moveable seats and bleachers grouped around different types of stage.

The two main rehearsal rooms are lit naturally, but can be blacked out when needed. It was decided that the interiors would remain about the performance and the performers rather than strong architectural elements. Extra care was taken to keep the exterior architecture form inhibiting the show, extra insulation was used to muffle the sound of rain if it were to fall on the metal roof.

The Final cost for this unique structure was 62 million ("Foil to Nature.")

I think Gehry's Performing Arts Centre is definitely unique and definitely a Frank Gehry building. At first I

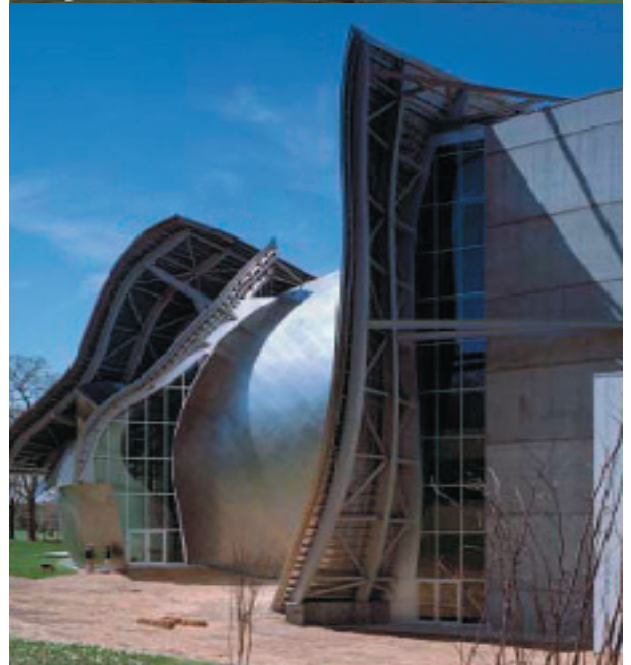
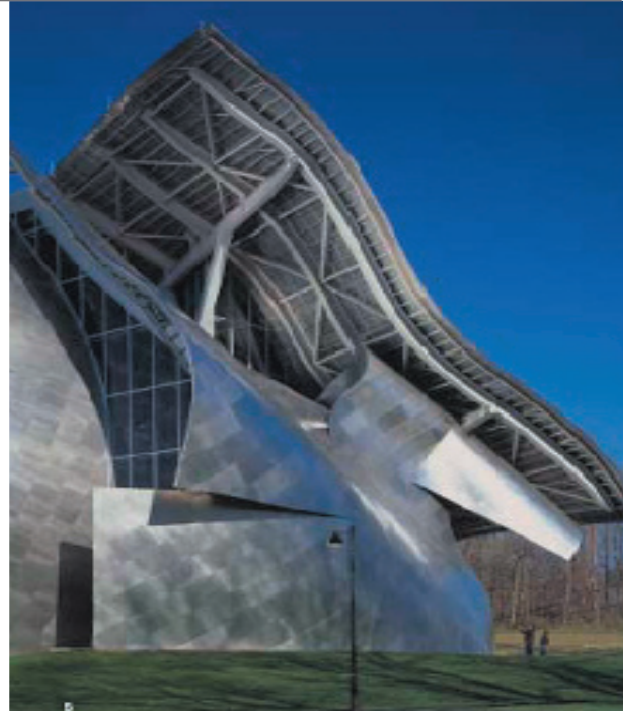

# PERFORMING ARTS CENTRE ANNAPOLIS ON HUDSON

was a little apprehensive of the foil structure, it seemed a little obtrusive to me. But one has to appreciate the way Gehry disguised what could have ended up being somewhat like a back-up at a box factory. I enjoy the way the foiling creates notches and outpoints on the facade that can be punched with glazing. The foiling definitely illustrates the university's commitment to the arts.

Another thing that was important about the project was the issues of site location. It was interesting how some land is just so sacred for the build environment to take over. I think it's good that people appreciate small pieces of history and are willing to work to maintain them.

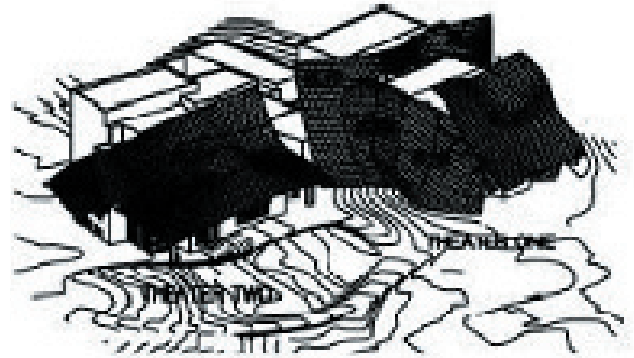

geometry of building elements in relation to landscape, north elevation

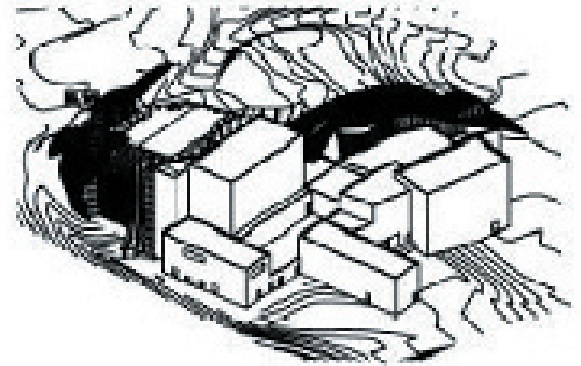

geometry of building elements in relation to landscape, north elevation





# performing arts centre annapale on hudson

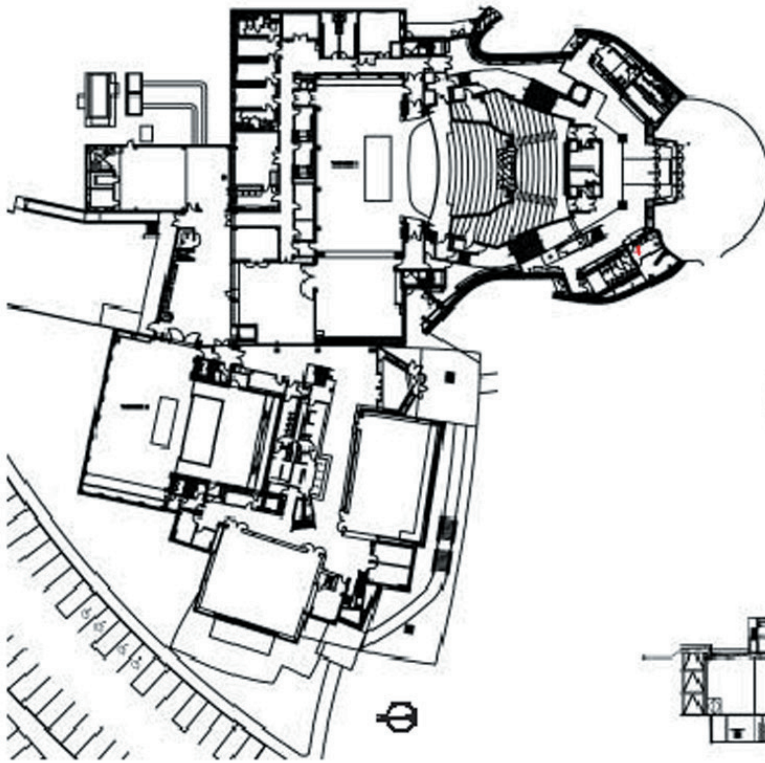

r composite stage level plan (scale approx 1:1000)

- |                   |                      |
|-------------------|----------------------|
| 1 entrance        | 11 stage manager     |
| 2 foyer           | 12 costume shop      |
| 3 concessions     | 13 instrument store  |
| 4 box office      | 14 store             |
| 5 wcs             | 15 scenery workshop  |
| 6 Sosnoff Theater | 16 loading dock      |
| 7 stage           | 17 black box theatre |
| 8 green room      | 18 offices           |
| 9 dressing rooms  | 19 drama studio      |
| 10 practice room  | 20 dance studio      |



long section through black box theatre

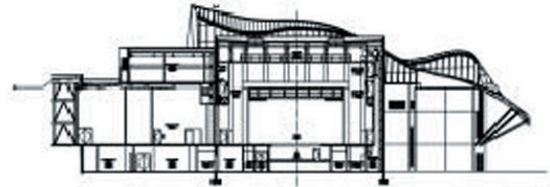

cross section through black box theatre

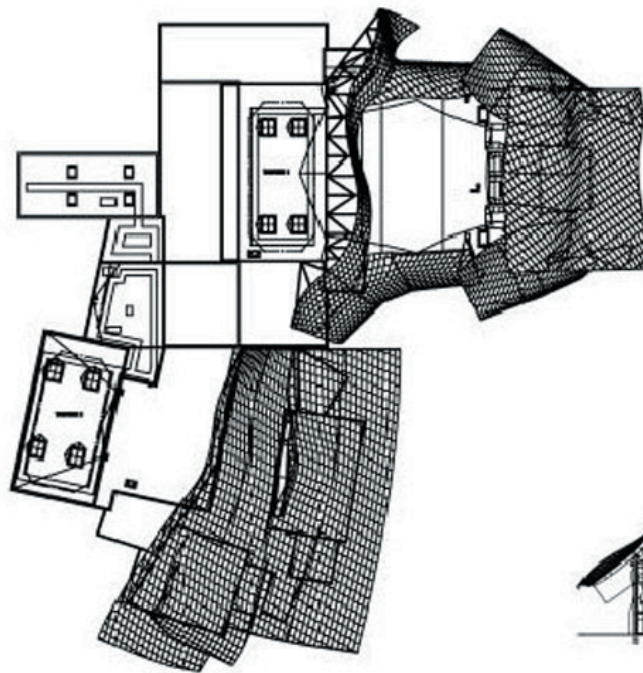

composite roof level plan

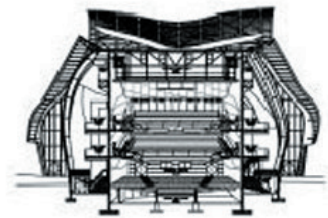

cross section through Sosnoff auditorium

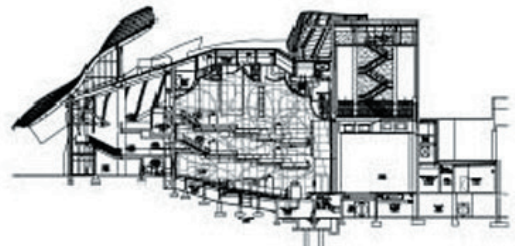

long section through Sosnoff auditorium

performing arts centre annapdale on hudson

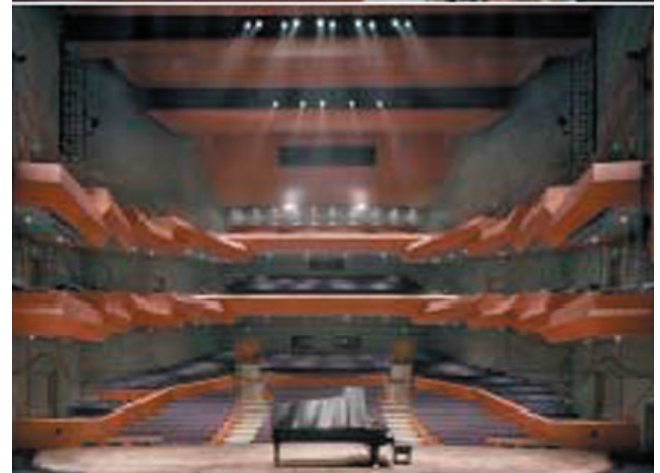
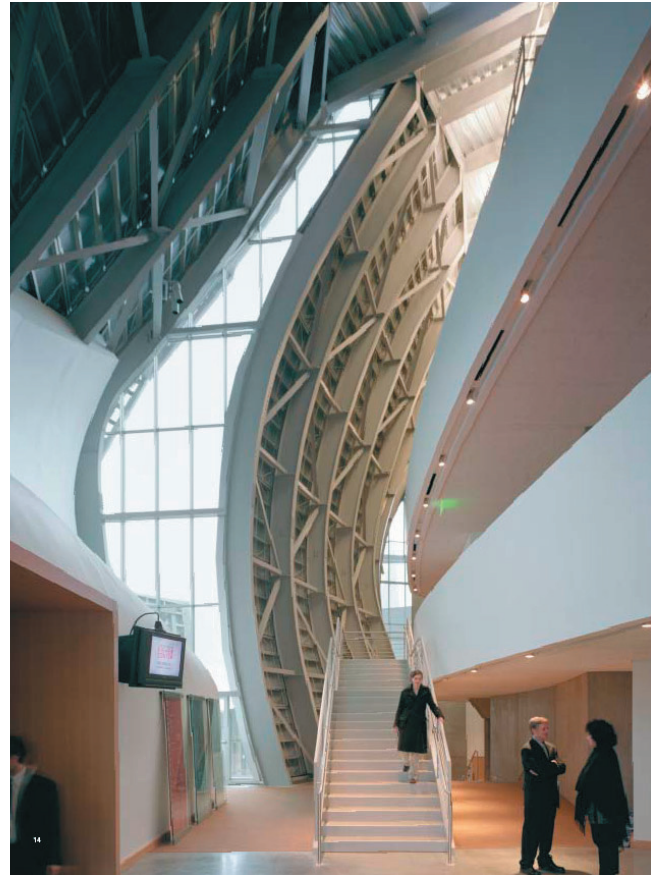





## SUSTAINABLE ECOLOGICAL SCHOOL CAUDRY, FRANCE

Designed by Lucien Kroll, the Ecological School in Caudry, France is designed to highest environmental standards. Part of a competition the school incorporates aspects in: running energy, embodied energy, lighting environmental quality, rainwater, sustainability, toxicity of materials, long and short term pollution, potential re-use and recycling, even waste management on the building site.

The HQE (Haute Qualite Environnementale) laid out 67 performance criteria, those participating in the competition had to bid on who could achieve the minimum environmental load. If this amount was overdrawn they financial penalties were used. Performance was to be measured on site after completion so the predictions had to be accurate.

The buildings were to be on East-West alignment. This allowed for the sunny south side to gain solar exposure, but is also managed with shading devices.

Ecological design was also visible in the treatment of the landscape. Green roofs, new ponds to the east and a hillside to the west. The green roofs were

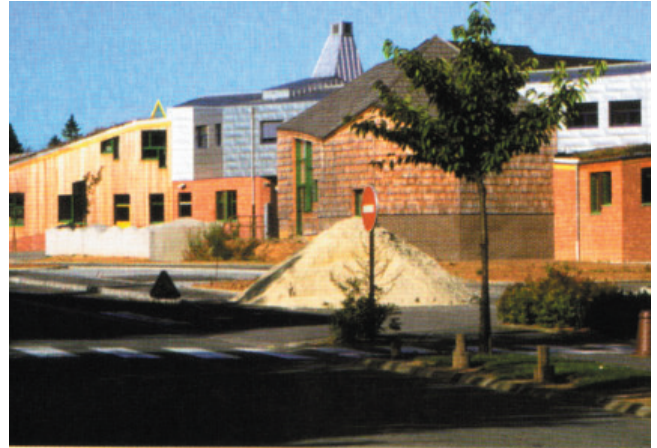



## SUSTAINABLE ECOLOGICAL SCHOOL CAUDRY, FRANCE

placed on every possible no or low-sloped roofs. This increased the insulation, and avoids the need for a surface treatment. The benefits of green roofs are numerous, the vegetation absorbs rain and delays run-off.

The purpose for the ponds are also multiple. Along with being wildlife habitats, there are also reservoirs for the rainwater system. This system supply water for flushing toilets and and absorbing run-off that could potentially cause flash floods elsewhere.

The newly added hill shades the building from the west. This side is evidently the most difficult side for unwanted solar gain. This hill was made entirely of soil dug for the buildings on the site. This saved transporting energy or generating pollution being dumped somewhere else.

The complex is a group of buildings rather than one single building. And each of these individual parts would have a separate identity. This shows that the complex is diverse and like a small city.



**ECOLOGICAL SCHOOL,  
CAUDRY, FRANCE**  
ARCHITECT  
**LUCIEN KROLL**

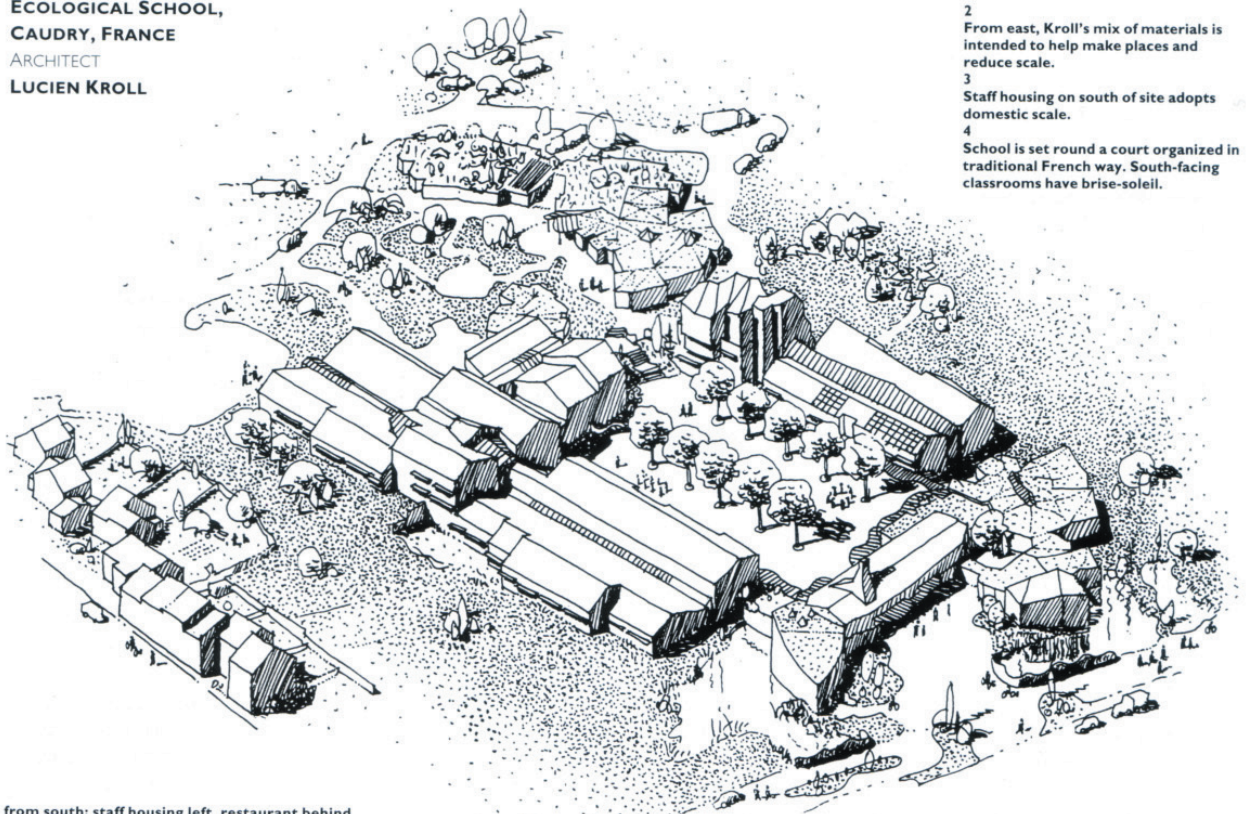

- 2 From east, Kroll's mix of materials is intended to help make places and reduce scale.
- 3 Staff housing on south of site adopts domestic scale.
- 4 School is set round a court organized in traditional French way. South-facing classrooms have brise-soleil.

from south: staff housing left, restaurant behind

## SUSTAINABLE ECOLOGICAL SCHOOL CAUNDRY, FRANCE

The whole complex is focused around a center court which is open to the public. It is lined with trees on a grid for summer shade.

The classrooms are rectilinear in nature, conditioned by daylight and set in a linear fashion. Social spaces for larger groups are more complex forms with faceted roofs.

The materials used avoided all high embodied energy or further than 200km from the site. Materials that would last a long time were used. Plastics were avoided as much as possible. Recycled paper was used for the main insulation, 150mm thick for roofs and 180mm for walls. Potentially harmful solvents in paints and glues were avoided, for everyone involved; the construction workers and children and staff. Linoleum turned out to be the most ecological because it is 86% recyclable. Timber was used structurally. Concrete was used for fireproofing and ground-based parts and also for thermal mass (Jones).



sustainable ecological school çAUNDRY, FRANCE





# sustainable ecological school caunbray, france



- 1 entrance
- 2 administration
- 3 pupil's common room
- 4 technical teaching
- 5 general learning
- 6 arts tower
- 7 information centre
- 8 general purpose hall
- 9 infirmary
- 10 restaurant

first floor



ground floor (scale approx. 1:1250)

## LIVING ARCHITECTURE MARCEL KALBERER

One important concept I hope to incorporate in my design is nature. This article I found is the epitome of nature and architecture; nature as architecture. The idea for "Living Architecture" came from Swiss-born Architect, Marcel Kalberer.

This building incorporates a natural frame with organic elements encasing it. This building type can be used for carports, children's playhouses and large structures for social events.

The example show to the right is Vegetal Building in German by the above mentioned Marcel Kalberer. He choose to use willow that grows to its maturity in three to five years. In a way he plants his own architecture. This creation is formed through a process of planting, interweaving and binding. Kalberer choose to work with nature instead of against it. He sees how the planting is growing and works with it.

It's amazing to see how the structure is slowly filled in by the plantings to form an enclosure. This technique has been used through out the ages in rural areas, and was originally redeveloped by Kalberer using ancient Mesopotamian methods.

This technique for structure building is obviously eco-friendly, we have green roofs so why not green walls too. The amount of waste is also non-existent when the structure is no longer useful or useable it just disposes of itself over time adding to the ecosystem (Locksonen.)

I think this is just beautiful, it would be the perfect marriage of architecture and sustainability something I'm aiming for in my project. It would also blend to the natural surroundings of my site and would provide the inhabitants of the art community with amazing outdoor gathering space. I found more pictures at:

<http://www.sanftestrukturen.de/index.html>

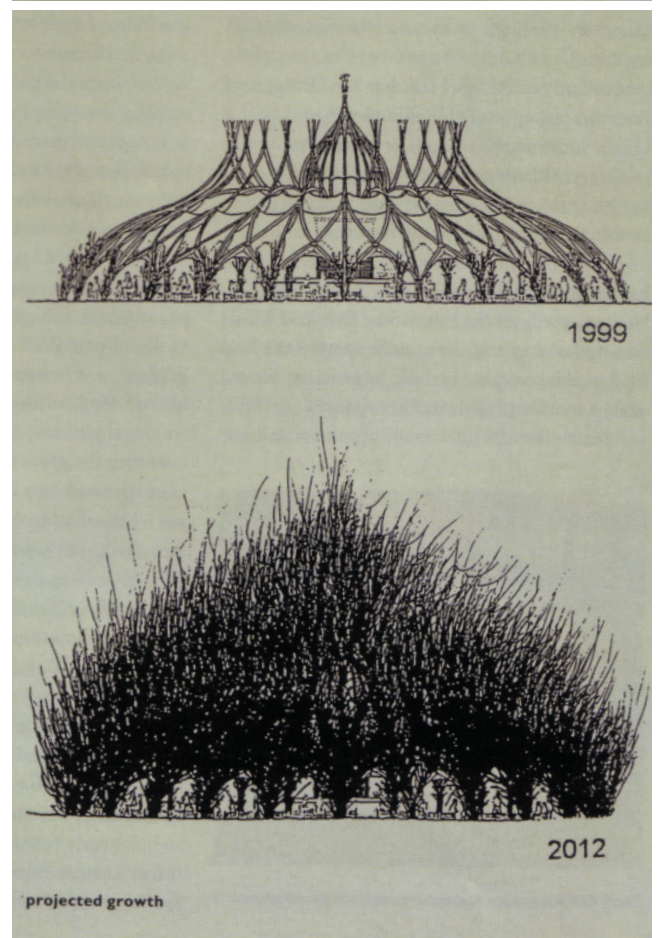
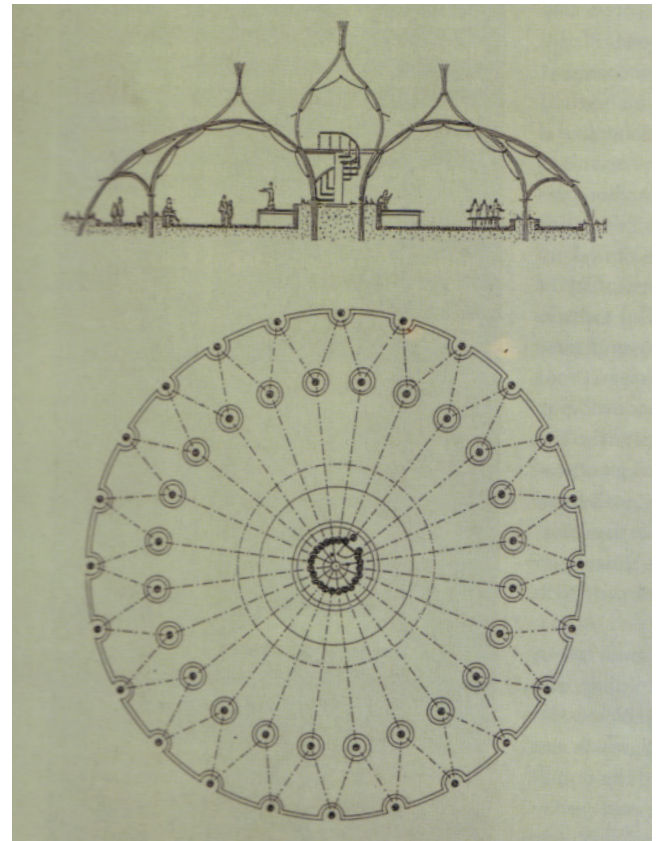



# LIVING ARCHITECTURE MARCEL CALBERG





## case study analysis

The hours I spent flipping through architecture magazines looking for fine architecture was definatley not wasted. I witness some really good examples and some rather poor ones. I chose to only show the ones I though were worth reviewing. I gained some really useful ideas from all of them.

### Interior:

The interior of the de Young was impressive with it's new way of looking at space configuration and the purpose of a wall. I really appreciated how the panel system doubled as a divider but also as additional space. That's important when the space is limited.

### Exterior:

The Gehry work that I described, to me, is a statement about the exterior treatment of architecture. Whether you agree with his design or not all must agree that Gehry takes risks (although he might keep taking the same risks) in the exterior of his buildings.

### Articulation of Space:

I felt the Renzo Piano structure was a beautiful elegant space. The large rounded sections each served a different purpose, and connected them was a long channel that house the circulation spaces. He allowed these spaces to be what they were, unlike Gehry who felt he needed to cover them up. I also appreciated the cues Piano took from the rolling landscape.

### Programming:

The STUK was also important in it's allocation of space. It was really useful that they gave me all the dimension of the spaces for visualization. Another thing I found really helpful about the STUK institute was their "box-in-a-box" design. By treating each individual theatre as it's own space their were given a design freedom. And with this freedom came the controllability of acoustics and mechanics. I also loved the idea of connecting green spaces. This system is perfect for a center where a community environment is important to develop.

### Sustainability:

The case study of the treehouses was important to me for my design. I would like to create something on the housing side that's whimsical, inviting and different. The treehouse environment also allows for a certain level of sustainability. The "Living Architecture" design is also important with this idea of sustainability.

The ecological school was a prime example of sustainability. The designers on the project took every possible ecological solution and ran with it. No possibility was left unnoticed and in the end a aesthetic, functional, sustainable structure was built.

## historic context

### Chautauqua Movement

Throughout the history of America and the world there have been movements that have led to enlightenment. One such movement was the Chautauqua Movement. This movement like many movements grew out of something small and into something widely known. In the 1870s, the Methodist Episcopal church, held summer Sunday school institutes. At a regular camp meeting in 1873, Bishop John H. Vincent proposed the camp to be something more. He that the education be expanded to more than just religious topics.

The next summer the Chautauqua Assembly was established at Lake Chautauqua, New York. This assemblies offered education in both science and humanities. Thousands would come to the eight-week sessions to hear lectures by politicians, authors, artists and scientists. Education as well as entertainment was the draw to these assemblies.

In 1878 William Rainey Harper added a course in home reading. This added course spread the movement nationwide. "Traveling Chautauquas" were organized, shortly after the turn of the century. These traveling lectures were organized by commercial lecture bureaus. Tent shows moved from town to town in the summer spreading and enlightening through lectures and entertainment. They success blossomed for two decades until after WWI when they started to lose audiences, the movement ended in 1924. It continued however at the original location for many years but never with the success had in the beginning (Houghton Mifflin.)

### Interlochen

Interlochen originally started as a girls camp in 1918 and in 1922 a boys camp was added. In 1928 the National High School Orchestra Camp was established. It grew rapidly in size, scope and reputation and in 1931 became the National Music Camp. In 1942 the camp became affiliated with the University of Michigan. And in 1960 Interlochen Arts Academy was chartered to provide year round training in the creative arts. Since

then the camp has continued to thrive.

Originally a camp for music students, Interlochen now offers a place for young dancers, actors, writers and visual artists. Because of its long musical history it still houses the most number of musicians.

Interlochen is one of the world's oldest and most successful fine arts camps. The camp is offered for students aged 8 to 18, and provides a balance of education and recreation.

Situated on 1,200 acres of woods between two lakes in the northwest corner of lower Michigan, Interlochen provides a beautiful natural setting for budding artists. Although natural in setting it is not far off the beaten path and is easily accessible from the airport, bus terminal or by car from Chicago, Detroit and Grand Rapids.

Interlochen handles 2,100 students from all 50 states, the District of Columbia, Puerto Rico and more than 41 other countries. The faculty and staff come from prestigious universities, colleges and public schools, as well as professional performing organizations. Professional guests artists are also welcome. There are atleast one adult to every two campers at interlochen.

The camp is divided into three divisions:

- High School Division: For students who have completed grades 9, 10, 11 or 12. Students select either an audition-based major or non-audition-based major.
- Intermediate Division: For students who have completed grades 6, 7, 8 or 9. Students select either an audition-based major or non-audition-based major.
- Junior Division: Students have completed grades 3, 4, 5 or 6. There are no audition requirements.

## site analysis

Inspiration is key in my design concept. I want the individuals that come to my art center to feel transcended. I feel the site I have chosen will definitely inspire this feeling that will to so many great works.

My site is situated on the north side of Lake L'Homme Dieu in Alexandria, MN. The site will become almost as important as the building itself because of its ability to inspire. This site was important for me to use because of its natural beauty. It also provides a beautiful setting to experience art in nature and to appreciate its forms.

The part I find most special about this site is hard to explain in words. Growing up in the area, I loved the lakes. I don't think even love is even a strong enough word. Swimming, boating, fishing the lake was our second home. I probably spent just as much time at the beach in the water as I did on dry land. The smell, the air it still seems magical to me. This part of the area was always the most special for me. People just seem so much happier in the summer.

I remember looking at all the beautiful lake homes and wondered who was lucky enough to live in such a special place. This is one of the big reasons I chose my site, it's mystic quality. It's beautiful and would be a never ending environment for creative stimulant.

If that wasn't enough, I also chose the site for its functionality. My site is divided into two sections, the lake side and the wooded side, which is perfect for my divided program. The lake side of the road that site is nice and flat, a clear view straight to the lake. I would like to devise a way to use the site without blocking the whole view of the lake. This side of the site would be ideal for the community end of the institute, because of its accessibility to people of all physical abilities.

The other side of the road there is a slight hill and a grove of trees. This is where I envision a treehouse

community of sorts. The two areas would need to be bridged in some way. I would like to keep this natural, maybe through the incorporation of some living architecture so the residential side would look like an enchanted forest.

About a quarter to a half mile from my site there is a public water access, I thought this would be an excellent way for people to launch their boats and come over to enjoy one of the outdoor shows. The lake my site is on is nestled in a large chain of lakes that includes other options similar to this, a restaurant and a resort offer the same drive up service. An individual could make a whole day just boating around to different attractions in the area.

In the other direction on the same road there is another community of the same nature, Theatre L'homme Dieu. This theatre houses students from St. Cloud State University. These students live and produce plays on site. My hope is that my community along with the current Theatre L'homme Dieu could come together and draw a bigger crowd that either one could alone.



# site analysis

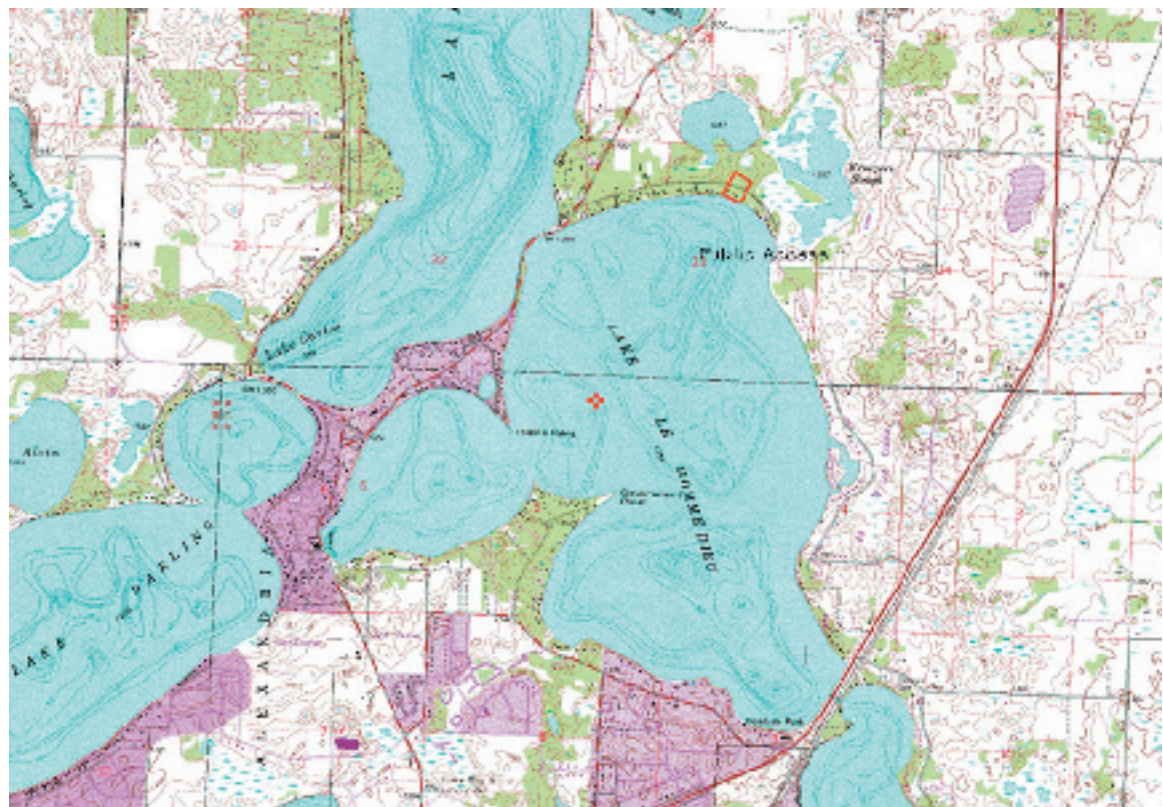
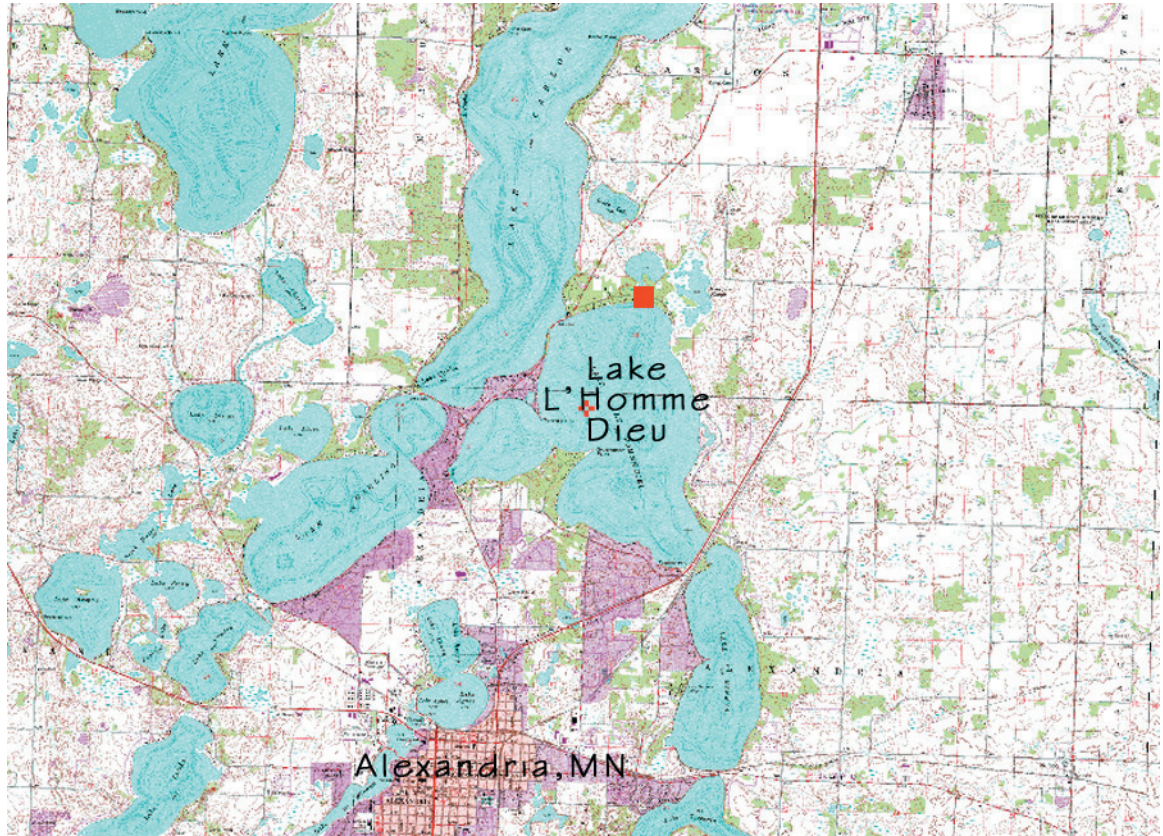



# site analysis





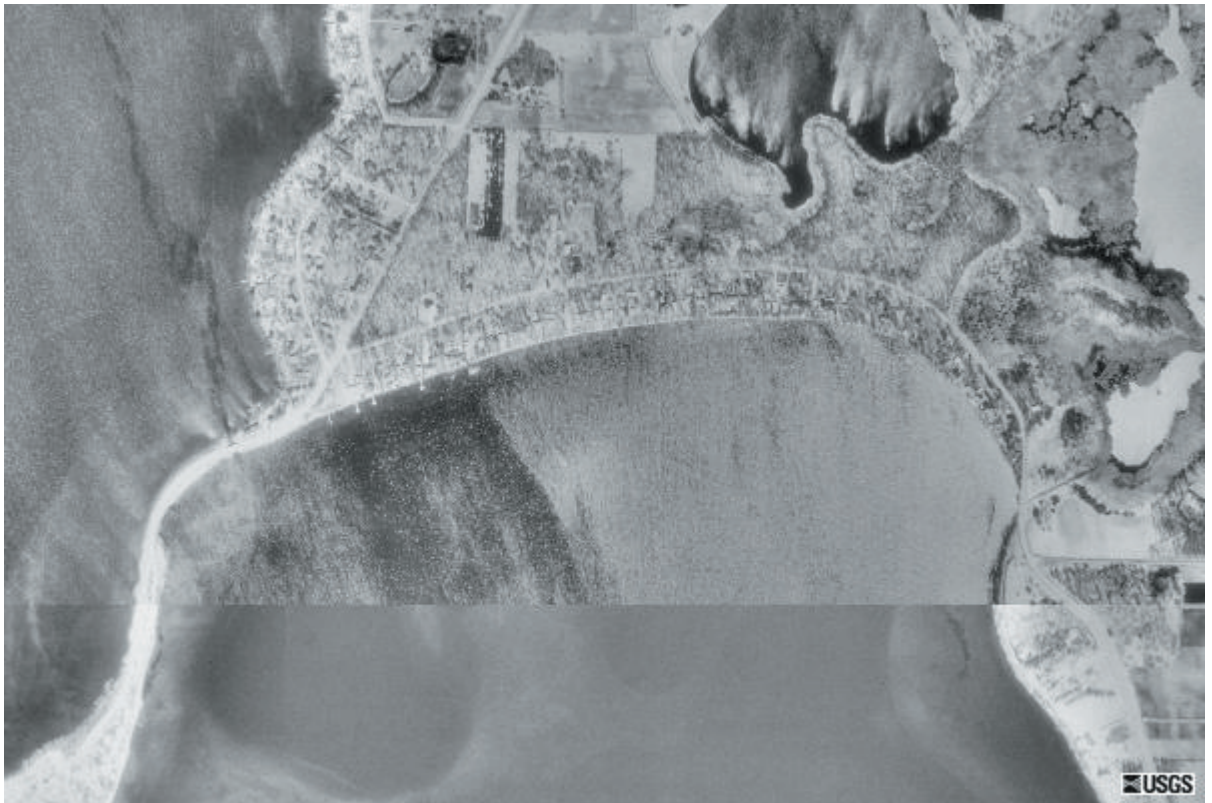

Aerial View of Site (Top) View from public access Looking in the Direction of the Site (Below)





# site analysis



Entry on to site: This road is a well maintain road that sees a fair amount of traffic. A lot of the traffic is for slow moving sight driving. The pictures I'm showing here are areas for some possible parking, and or expansion in the future. The picture directly above shows where the bridge cross the street would lie.



# site analysis



Wooded Side of the Site.

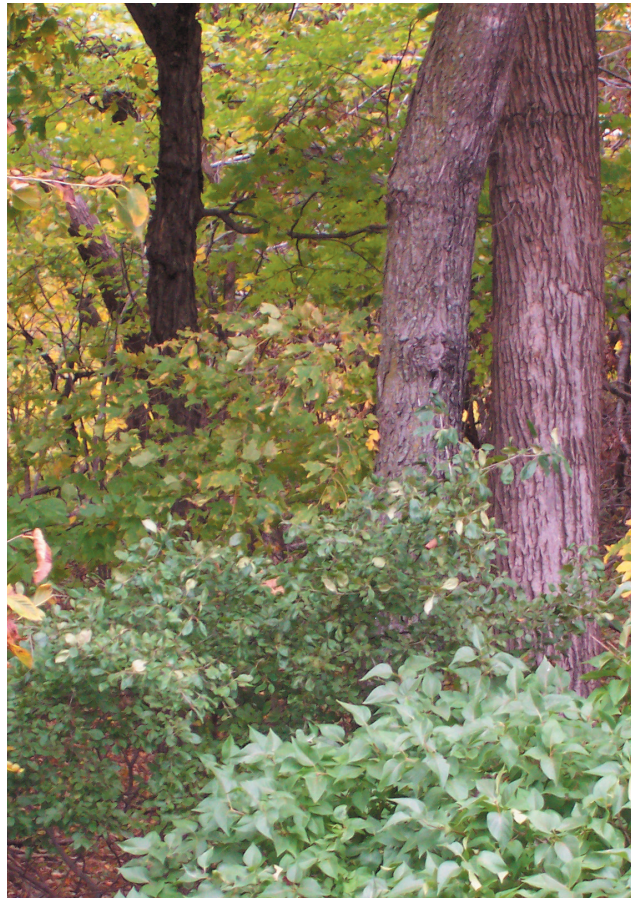
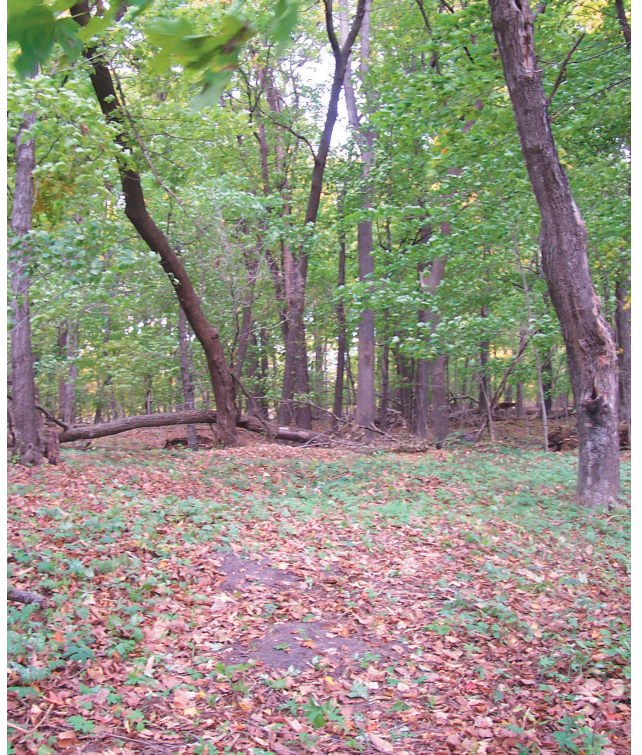



# site analysis



Public Lake Side: As you can see this side of the site is pretty well flat and has a good view to the lake. There are so smaller buildings that may be removed, if possible I will be keeping them.

## site analysis

### Light Quality:

The light quality on the flat lake side is pretty vibrant. The trees are tall and thin so a fair amount of light is allowed to reach the ground. Enough shade is given by these trees so that the sunlight is never blinding or overly hot.

On the more wooded side the trees pose more of a shade factor. There are patches where the trees are not as heavy and it allows the light to come in there. So there is some nice play between light and dark.

### Vegetation:

The vegetation in this area is pretty consistent over this region of MN. There is a mix of Elm, Oak and maple trees, which makes for a beauty fall landscape.

### Water:

Lake L'Homme Dieu is a very clean fairly deep lake. People swim on several beaches on this lake, and other forms of recreation take place; boating, fishing, jet skiing.

### Wind:

The site is on the north side of the lake, therefore the wind patterns are most favorable. In the winter the wind comes from the north/northwest therefore it is blowing from the site on to the lake. This keeps it from being so cold in the winter. And in the summer the winds generally blow from the south from the lake to the site, this provides the summer air with a nice cool breeze.

### Human Characteristics:

This south side of the site on the lake is completely groomed and has housing. The wooded south side is fairly untouched by man and has no dwellings near my site.

### Distress:

There is no distress to the site.

### Water Table:

Due to the proximity with the lake careful

attention will be paid height of the water table and it's relationship to the foundations of my structure. On visiting the site I noticed that all the houses in the area have basements, so the water table must not be too high in the area.

### Slope:

The slope on the site is pretty mild there are no drastic drop offs or hills that need to be considered. The only major landform is the hill on the north side of the site.

### Plant Cover:

The vegetation in the area is lush and healthy. There is a good mix of soil good for plantings, and the area is not really dry or really wet.



"Anthropology." en.wikipedia.org. 6 December 2005. <<http://en.wikipedia.org/wiki/Anthropology>>

Houghton Mifflin. "Chautauquamo Movement." 10 December 2005. <[http://college.hmco.com/history/readerscomp/rcah/html/ah\\_015600\\_chautauquamo.htm](http://college.hmco.com/history/readerscomp/rcah/html/ah_015600_chautauquamo.htm)>

"Determinism." en.wikipedia.org. 6 December 2005. <<http://en.wikipedia.org/wiki/Determinism>>

"Economics." en.wikipedia.org. 12 December 2005. <<http://en.wikipedia.org/wiki/Economics>>

"Empiricism." en.wikipedia.org. 8 December 2005. <<http://en.wikipedia.org/wiki/Empiricism>>

Europaconcorsi. The transformation of the arenberg institute into the stuk arts centre. 3 December 2005. <[www.europaconcorsi.com/db/pub/scheda.php?id=6911](http://www.europaconcorsi.com/db/pub/scheda.php?id=6911)>

Interlochen School of the Arts. December 10 2005. <<http://www.interlochen.org/default.htm>>

Jones. "Ecological School." *The Architectural Review*. January 2002.

"Lawson Willard Architecture." *Small Firms Great Projects*. 1 December 2005. <[www.smallfirmsgreatprojects.org/project.php?pid=204](http://www.smallfirmsgreatprojects.org/project.php?pid=204)>

Locksonen, Esa. "Living Architecture." *Architectural Review*. January 2002.

Nelson, Pete. *Treehouses of the World*. Harry N. Abrams, Inc. Publishers. 2003.

"Physics." en.wikipedia.org. 12 December 2005. <<http://en.wikipedia.org/wiki/Physics>>

"Semiotics." en.wikipedia.org. 6 December 2005. <<http://en.wikipedia.org/wiki/Semiotics>>

"Sociology." en.wikipedia.org. 6 December 2005. <<http://en.wikipedia.org/wiki/Sociology>>

"Transcendentalism." en.wikipedia.org. 12 December 2005. <<http://en.wikipedia.org/wiki/Transcendentalism>>

Michael Webb. "Foil to Nature." *The Architectural Review*. July 2003.

Webb, Michael. "Monument for a Miniaturist." *The Architectural Review*. August 2005.

# design documentation

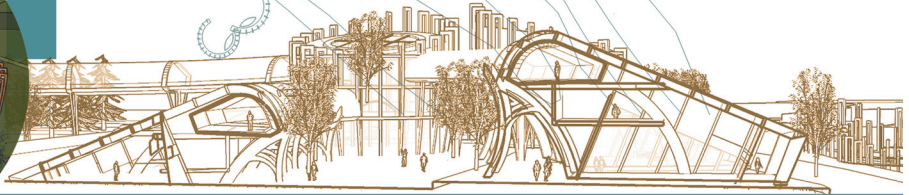
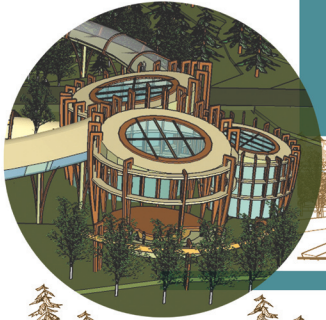
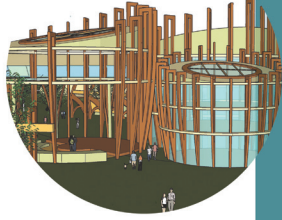

section through studios, illustrating the inhabitants ability to see into the studios from the gallery

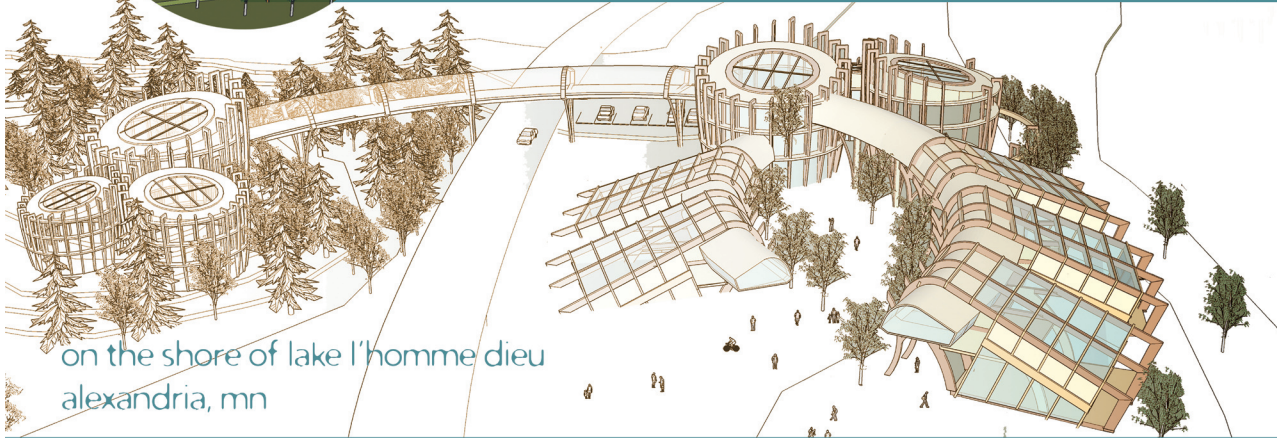

on the shore of lake l'homme dieu  
alexandria, mn

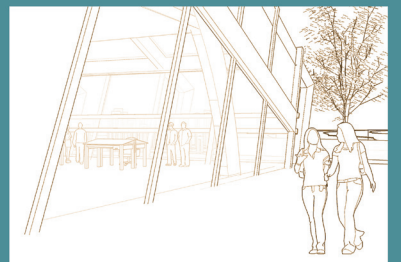
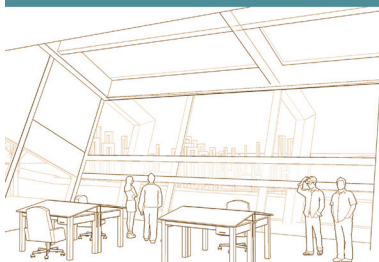



# design documentation

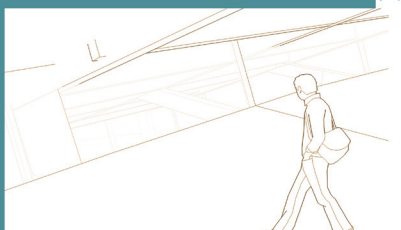
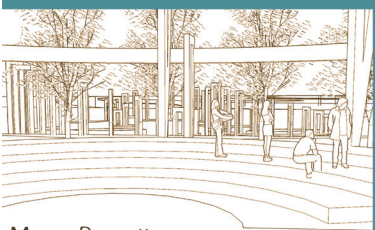
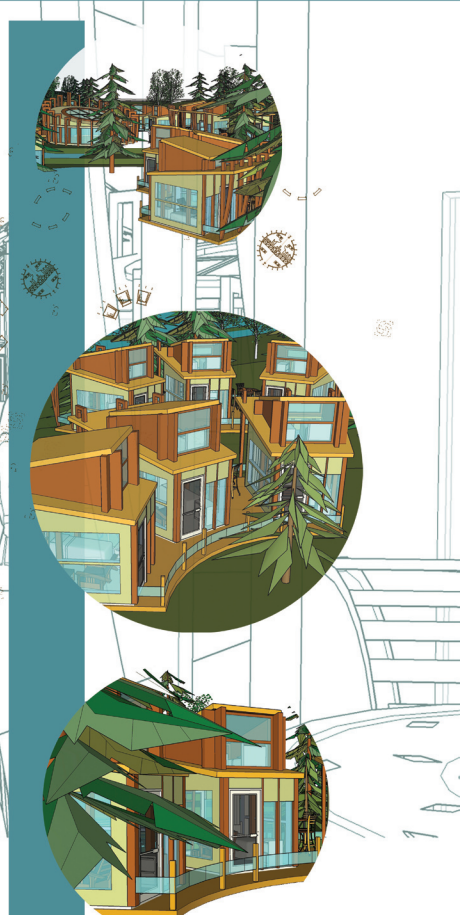
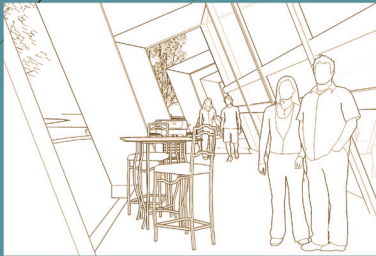
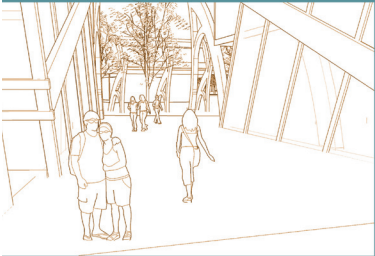
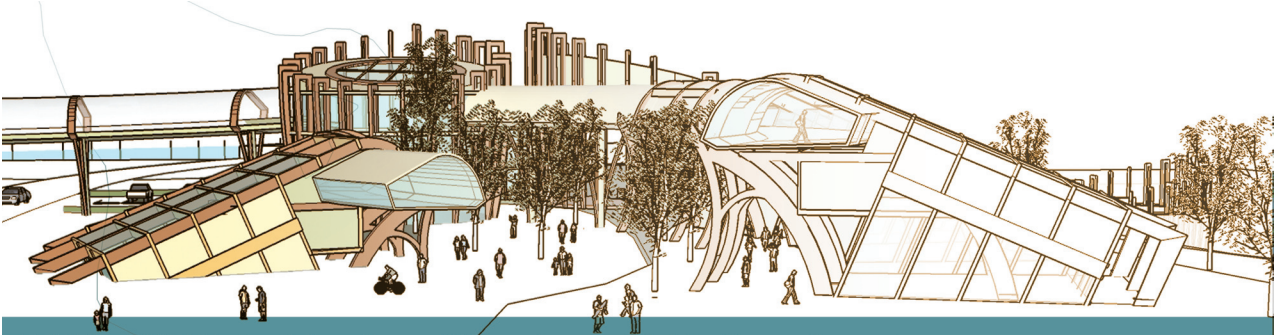

Megan Prescott

The site I have chosen is divided by a road. On the south side of the road, the lake side, I have placed all the buildings that will also be used by the community. The north side houses the residential suites, shown above. These smaller units are to be used mainly in the summertime when the institute is full, their necessities are located in three small bath houses, and in the community buildings. In the winter, the residents that visit the institute will stay in the south community building.



# design documentation



Preliminary sketches were done like the one below to determine the master plan.

In the final design I constructed a model to experience the forms and structure in three dimensions.

