



reIMAGINING THE POLICE STATION

Micah Swedeen



Trust in Police

43%

48% in 2013

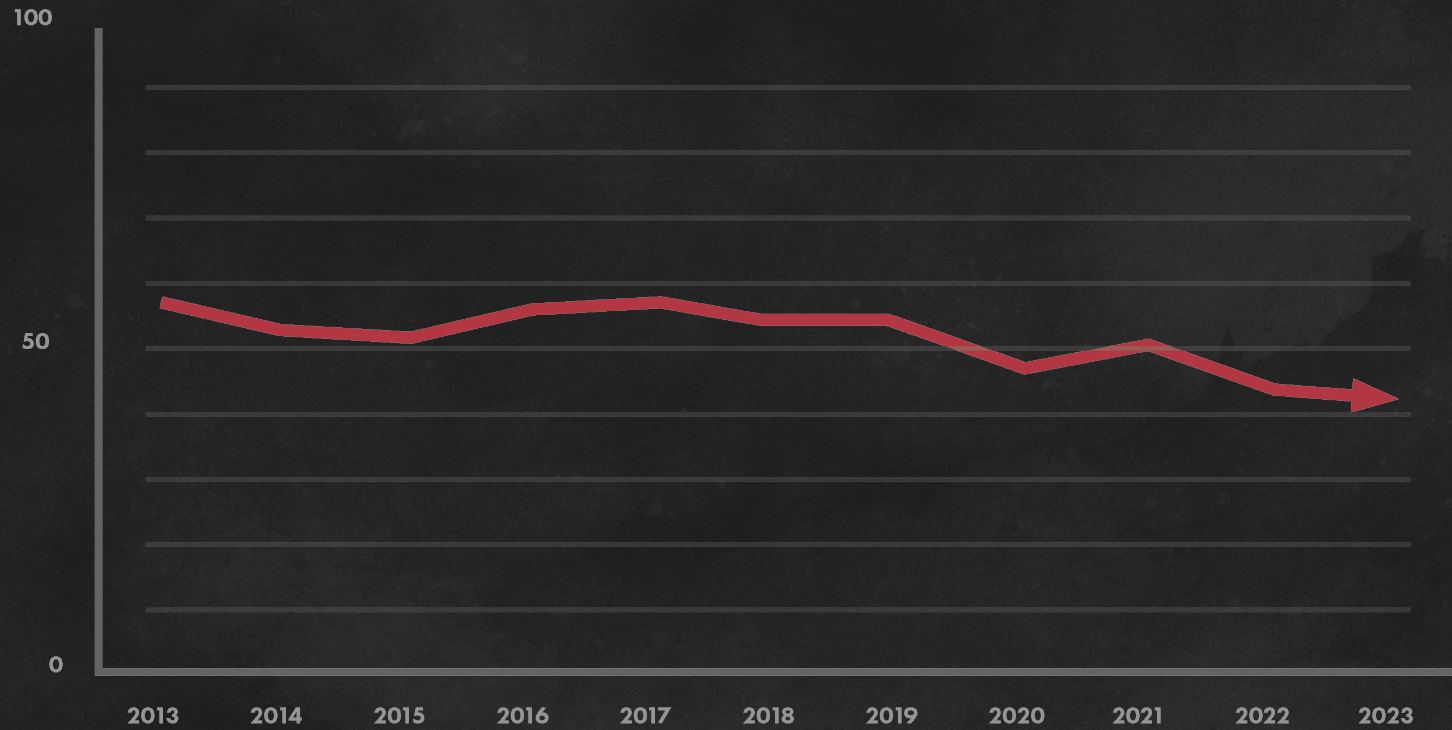

Confidence in U.S. Institutions, by Racial Group

% A great deal/Quite a lot of confidence

● White adults ● Black adults

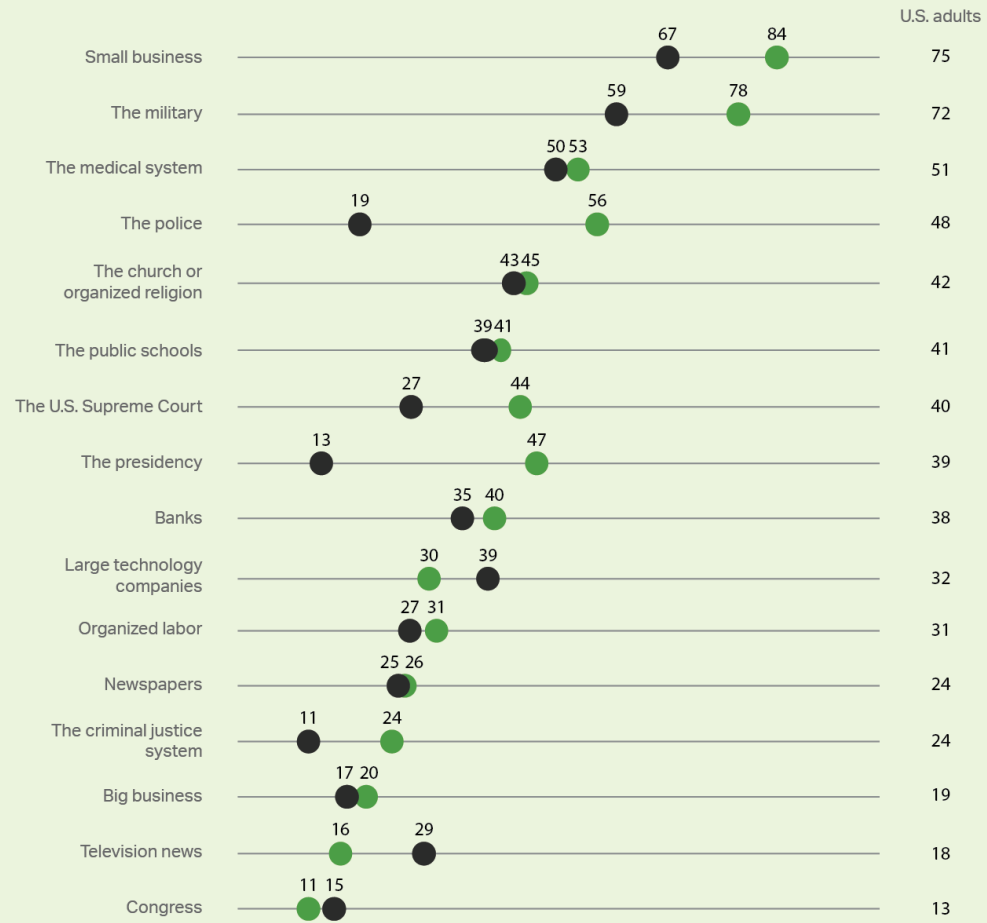

GALLUP, JUNE 8-JULY 24, 2020

Confidence in U.S. Institutions, by Racial Group

% A great deal/Quite a lot of confidence

● White adults ● Black adults

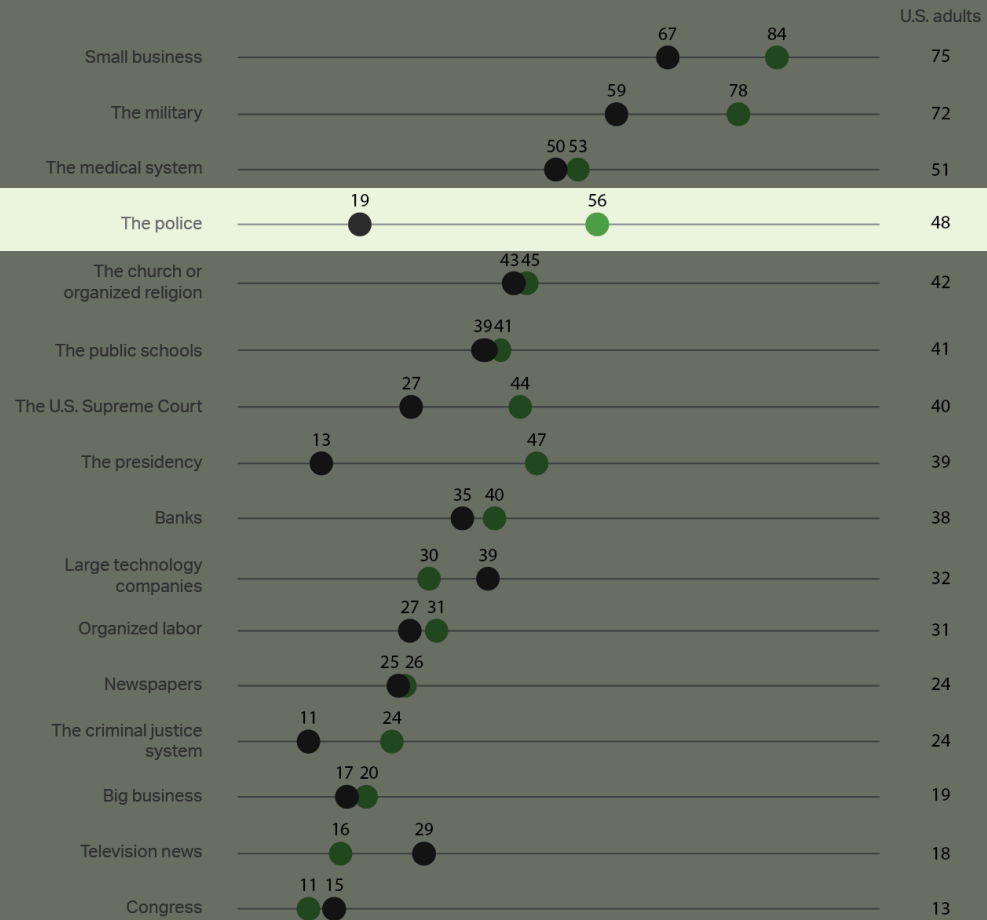

GALLUP, JUNE 8-JULY 24, 2020

GAP
37pts.
Largest Divide

BACKGROUND

SLAVE PATROLS

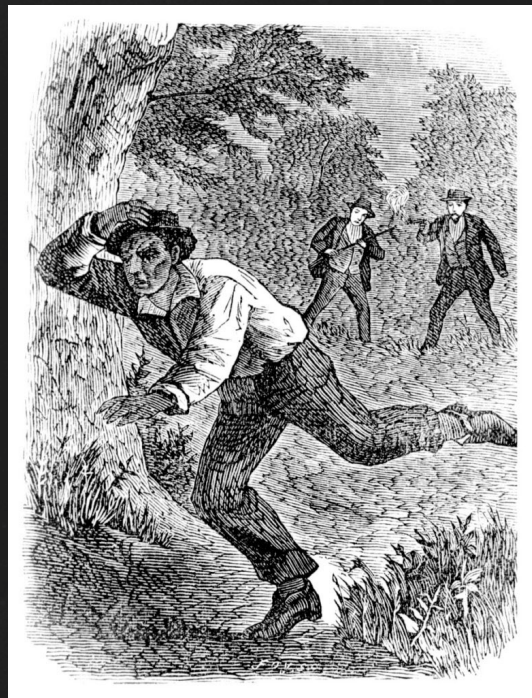

1700s-CIVIL WAR

JIM CROW ERA



CIVIL WAR - 1965

GEORGE FLOYD



2020



CYCLE OF DISTRUST





CYCLE OF DISTRUST

HISTORICAL BIAS IN POLICING





CYCLE OF DISTRUST

HISTORICAL BIAS IN POLICING

**GENERATIONAL
DISTRUST**





CYCLE OF DISTRUST

HISTORICAL BIAS IN POLICING

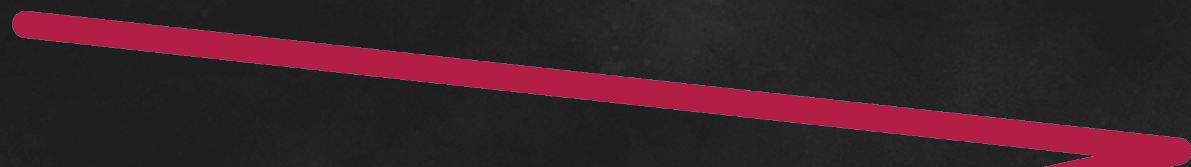

**GENERATIONAL
DISTRUST**

**LACK OF COOPERATION
WITH THE POLICE**





CYCLE OF DISTRUST

HISTORICAL BIAS IN POLICING

**GENERATIONAL
DISTRUST**

**LACK OF COOPERATION
WITH THE POLICE**

**POLICE BECOME
LESS EFFECTIVE**

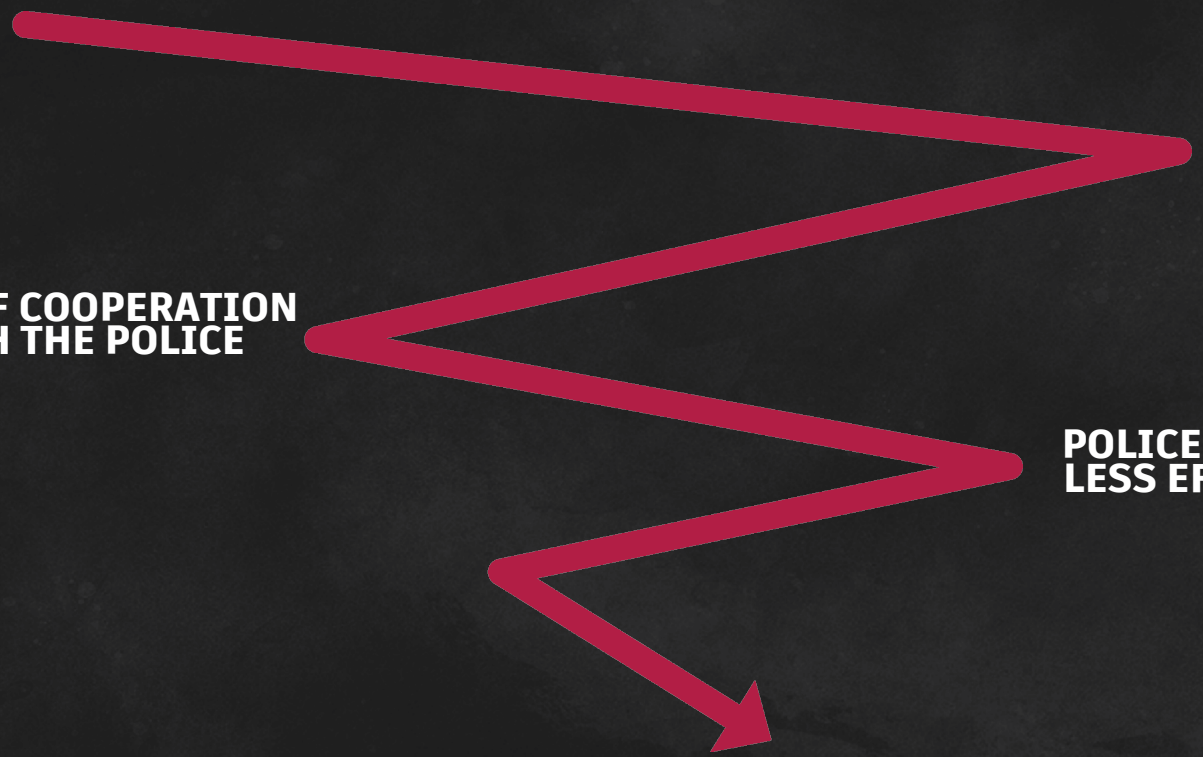



CYCLE OF DISTRUST

HISTORICAL BIAS IN POLICING

**GENERATIONAL
DISTRUST**

**LACK OF COOPERATION
WITH THE POLICE**

**POLICE BECOME
LESS EFFECTIVE**

**MORE CRIME GOES
UNPUNISHED**





CYCLE OF DISTRUST

HISTORICAL BIAS IN POLICING

**GENERATIONAL
DISTRUST**

**LACK OF COOPERATION
WITH THE POLICE**

**POLICE BECOME
LESS EFFECTIVE**

**MORE CRIME GOES
UNPUNISHED**

**DISTRUST GROWS ON
BOTH SIDES**





THESIS PREMISE

How do we rebuild trust?

A photograph showing several Camden County Police officers in uniform interacting with a woman in a red shirt and patterned shorts standing on the steps of a residential building. The scene is set in front of a multi-story building with a brick facade and a mailbox labeled '406'. The image is overlaid with a semi-transparent white box containing the title text.

Community Policing

Camden, New Jersey



How can design support community policing and rebuild trust through the built environment?



RESEARCH



Polis Station

Studio Gang

Polis Station History of Police Stations

1850s
FIRST STATIONS
Multiple U.S. Cities
(1800 ft²)

After decades of using spare space within other civic institutions, police departments establish their own station buildings.

1890s
ROW HOUSE STATION
Multiple U.S. Cities
(1000 ft²)

Stations are embedded in the rapidly densifying urban fabric.

CALL BOX
Multiple U.S. Cities
(1 ft²)

Call boxes appear on the streets shortly after the invention of the telephone. Police and trusted members of the community have access to make calls to the police station.

1930s
STATION FOR THE AUTO AGE
Early Prototype, Chicago
(4000 ft²)

The automobile changes the physical requirements of police stations and enlarges the area of patrol.

1960s
FORTRESS STATION
2nd District Station, Chicago
(45,000 ft²)

Now large hierarchical institutions, police stations grow to house multiple specialized units and administrative staff.

1980s
CIVIC STATION
24th District Station, Chicago
(35,000 ft²)

In an effort to soften the perception of the police, stations become less imposing and include public plazas.

2000s
TODAY'S STATION
10th District Station, Chicago
(48,000 ft²)

Today, Chicago's station prototype is sited on a major thoroughfare, flanked by expansive parking lots.

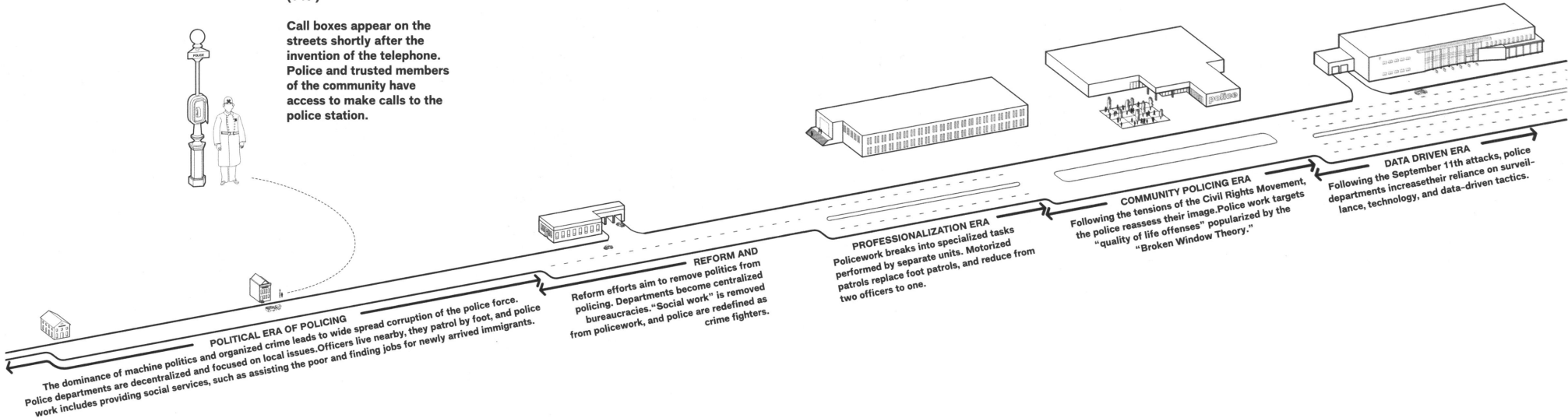

Polis Station History of Police Stations

1850s
FIRST STATIONS
Multiple U.S. Cities
(1800 ft²)

After decades of using spare space within other civic institutions, police departments establish their own station buildings.

1890s
ROW HOUSE STATION
Multiple U.S. Cities
(1000 ft²)

Stations are embedded in the rapidly densifying urban fabric.

CALL BOX
Multiple U.S. Cities
(1 ft²)

Call boxes appear on the streets shortly after the invention of the telephone. Police and trusted members of the community have access to make calls to the police station.

1930s
STATION FOR THE AUTO AGE
Early Prototype, Chicago
(4000 ft²)

The automobile changes the physical requirements of police stations and enlarges the area of patrol.

1960s
FORTRESS STATION
2nd District Station, Chicago
(45,000 ft²)

Now large hierarchical institutions, police stations grow to house multiple specialized units and administrative staff.

1980s
CIVIC STATION
24th District Station, Chicago
(35,000 ft²)

In an effort to soften the perception of the police, stations become less imposing and include public plazas.

2000s
TODAY'S STATION
10th District Station, Chicago
(48,000 ft²)

Today, Chicago's station prototype is sited on a major thoroughfare, flanked by expansive parking lots.

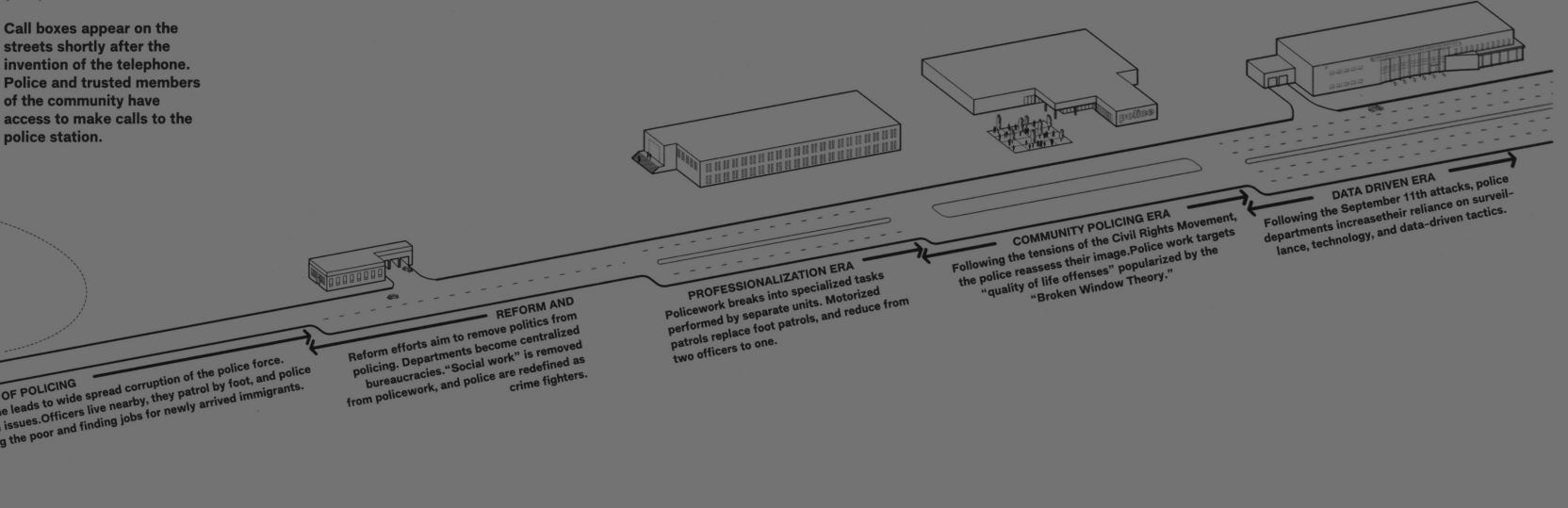

Polis Station History of Police Stations

1850s
FIRST STATIONS
Multiple U.S. Cities
(1800 ft²)

After decades of use, space within other institutions, police departments establish their own buildings.

The dominance of Police departments work includes pro

1890s
ROW HOUSE STATION
Multiple U.S. Cities
(1000 ft²)

Stations are embedded in the rapidly densifying urban fabric.

CALL BOX
Multiple U.S. Cities
(1 ft²)

Call boxes appear on the streets shortly after the invention of the telephone. Police and trusted members of the community have access to make calls to the police station.

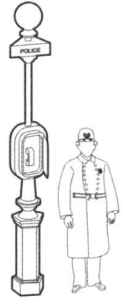

1930s
STATION FOR THE AUTO AGE
Early Prototype, Chicago
(4000 ft²)

The automobile changes the physical requirements of police stations and enlarges the area of patrol.

1960s
FORTRESS STATION
2nd District Station, Chicago
(45,000 ft²)

Now large hierarchical institutions, police stations grow to house multiple specialized units and administrative staff.

1980s
CIVIC STATION
24th District Station, Chicago
(35,000 ft²)

In an effort to soften the perception of the police, stations become less imposing and include public plazas.

2000s
TODAY'S STATION
10th District Station, Chicago
(48,000 ft²)

Today, Chicago's station prototype is sited on a major thoroughfare, flanked by expansive parking lots.

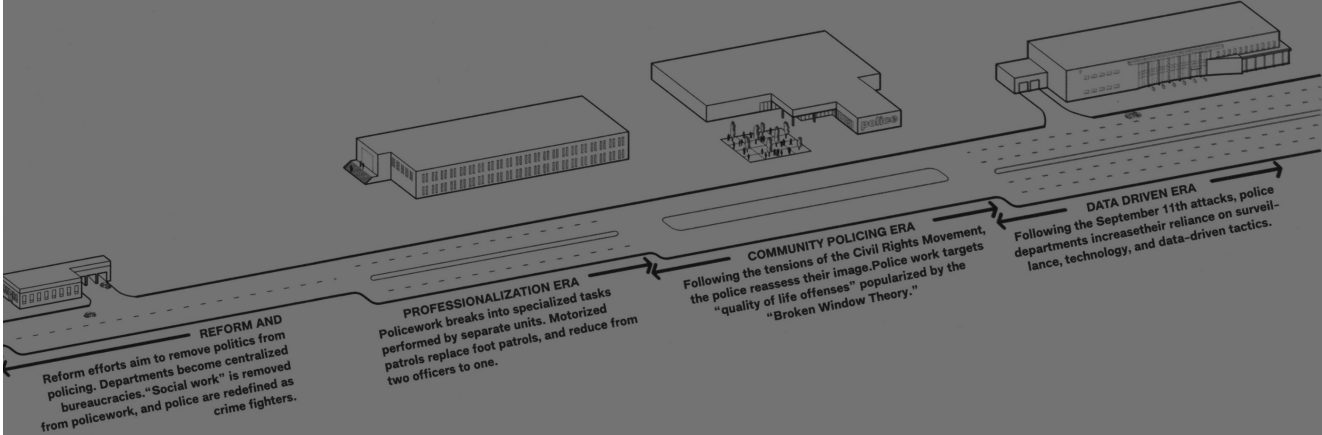

Polis Station History of Police Stations

**1850s
FIRST STATIONS**
Multiple U.S. Cities
(1800 ft²)

After decades of using spare space within other civic institutions, police departments establish their own station buildings.

**1890s
ROW HOUSE STATION**
Multiple U.S. Cities
(1000 ft²)

Stations are embedded in the rapidly densifying urban fabric.

CALL BOX
Multiple U.S. Cities
(1 ft²)

Call boxes appear on the streets shortly after the invention of the telephone. Police and trusted members of the community have access to make calls to police station.



POLITICAL ERA OF POLICING
The dominance of machine politics and organized crime leads to wide spread corruption. Police departments are decentralized and focused on local issues. Officers live nearby, their work includes providing social services, such as assisting the poor and finding jobs for them.

**1930s
STATION FOR THE AUTO AGE**
Early Prototype, Chicago
(4000 ft²)

The automobile changes the physical requirements of police stations and enlarges the area of patrol.

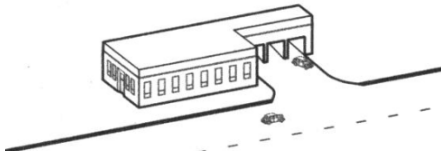

**1960s
FORTRESS STATION**
10th District Station, Chicago (45,000 ft²)

Now large hierarchical institutions, police stations now house multiple specialized units and administrative staff.

**1980s
CIVIC STATION**
24th District Station, Chicago (35,000 ft²)

In an effort to soften the perception of the police, stations become less imposing and include public plazas.

**2000s
TODAY'S STATION**
10th District Station, Chicago (48,000 ft²)

Today, Chicago's station prototype is sited on a major thoroughfare, flanked by expansive parking lots.

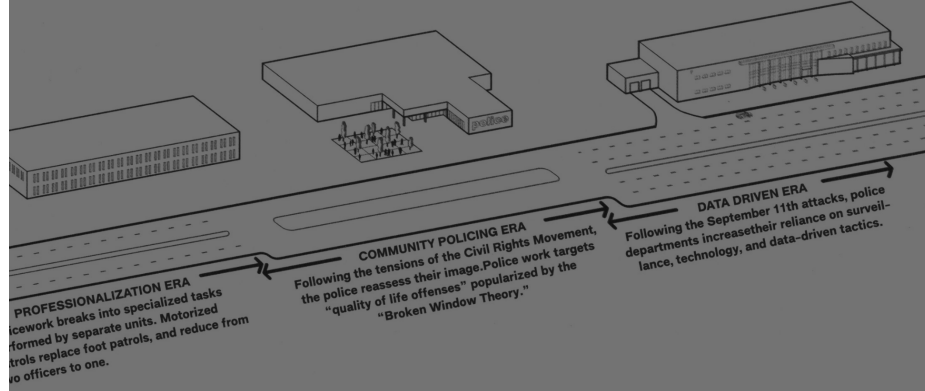

Polis Station History of Police Stations

1850s
FIRST STATIONS
Multiple U.S. Cities
(1800 ft²)

After decades of using spare space within other civic institutions, police departments establish their own station buildings.

1890s
ROW HOUSE STATION
Multiple U.S. Cities
(1000 ft²)

Stations are embedded in the rapidly densifying urban fabric.

CALL BOX
Multiple U.S. Cities
(1 ft²)

Call boxes appear on the streets shortly after the invention of the telephone. Police and trusted members of the community have access to make calls to the police station.



1930s
STATION FOR THE AUTOMOBILE
Early Prototype, Chicago
(4000 ft²)

The automobile changes physical requirements for police stations and enlarges the area of patrol.

1960s
FORTRESS STATION
2nd District Station,
Chicago (45,000 ft²)

Now large hierarchical institutions, police stations grow to house multiple specialized units and administrative staff.

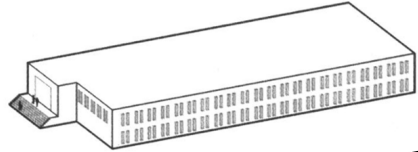

1980s
COMMUNITY POLICING STATION
10th District Station, Chicago
(5,000 ft²)

In an effort to soften the reception of the police, stations become less imposing and include public plazas.

2000s
TODAY'S STATION
10th District Station, Chicago
(48,000 ft²)

Today, Chicago's station prototype is sited on a major thoroughfare, flanked by expansive parking lots.

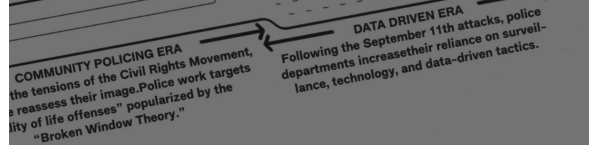
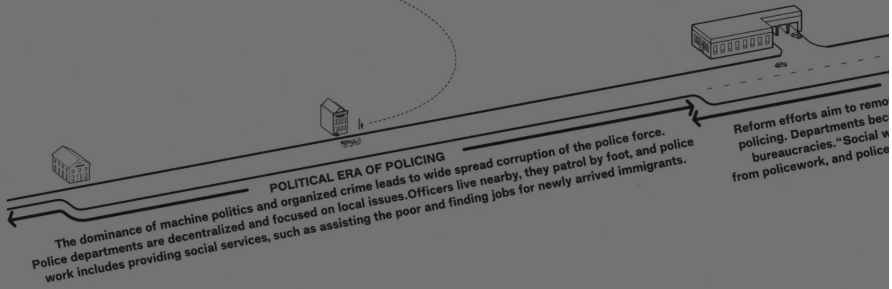
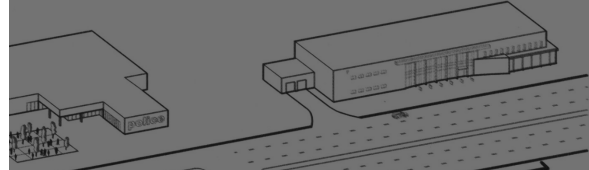

Polis Station History of Police Stations

1850s
FIRST STATIONS
Multiple U.S. Cities
(1800 ft²)

After decades of using spare space within other civic institutions, police departments establish their own station buildings.

1890s
ROW HOUSE STATION
Multiple U.S. Cities
(1000 ft²)

Stations are embedded in the rapidly densifying urban fabric.

CALL BOX
Multiple U.S. Cities
(1 ft²)

Call boxes appear on the streets shortly after the invention of the telephone. Police and trusted members of the community have access to make calls to the police station.



1930s
STATION FOR THE AUTO AGE
Early Prototype, Chicago
(4000 ft²)

The automobile changes the physical requirements of police stations and enlarges the area of patrol.

1960s
FORTRESS STATION
2nd District Station, Chicago
(45,000 ft²)

Now large hierarchical institutions, police stations grow to house multiple specialized units and administrative staff.

2000s
TODAY'S STATION
10th District Station, Chicago
(48,000 ft²)

Today, Chicago's station prototype is sited on a major thoroughfare, flanked by expansive parking lots.

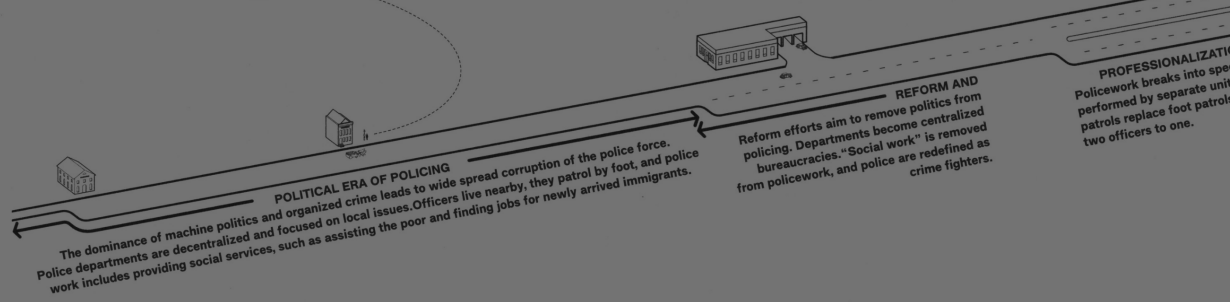

1980s
CIVIC STATION
24th District Station, Chicago
(35,000 ft²)

In an effort to soften the perception of the police, stations become less imposing and include public plazas.

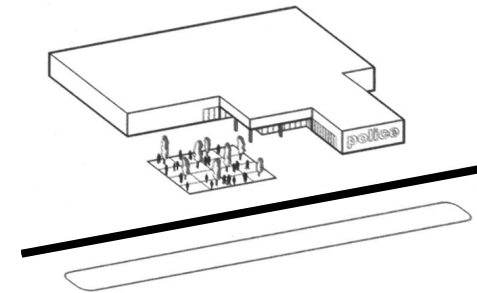

DATA DRIVEN ERA
September 11th attacks, police increase their reliance on surveillance technology, and data-driven tactics.

Polis Station

History of Police Stations

1850s
FIRST STATIONS
 Multiple U.S. Cities
 (1800 ft²)

After decades of using spare space within other civic institutions, police departments establish their own station buildings.

1890s
ROW HOUSE STATION
 Multiple U.S. Cities
 (1000 ft²)

Stations are embedded in the rapidly densifying urban fabric.

CALL BOX
 Multiple U.S. Cities
 (1 ft²)

Call boxes appear on the streets shortly after the invention of the telephone. Police and trusted members of the community have access to make calls to the police station.

1930s
STATION FOR THE AUTO AGE
 Early Prototype, Chicago
 (4000 ft²)

The automobile changes the physical requirements of police stations and enlarges the area of patrol.

1960s
FORTRESS STATION
 2nd District Station, Chicago
 (45,000 ft²)

Now large hierarchical institutions, police stations grow to house multiple specialized units and administrative staff.

1980s
CIVIC STATION
 24th District Station, Chicago
 (35,000 ft²)

In an effort to soften the perception of the police, stations become less imposing and include public plazas.

2000s
TODAY'S STATION
 10th District Station, Chicago
 (48,000 ft²)

Today, Chicago's station prototype is sited on a major thoroughfare, flanked by expansive parking lots.

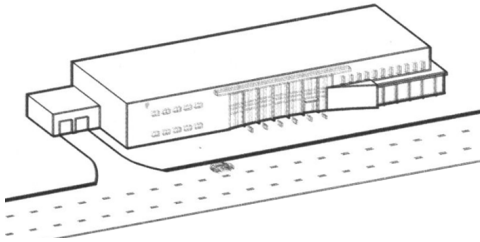
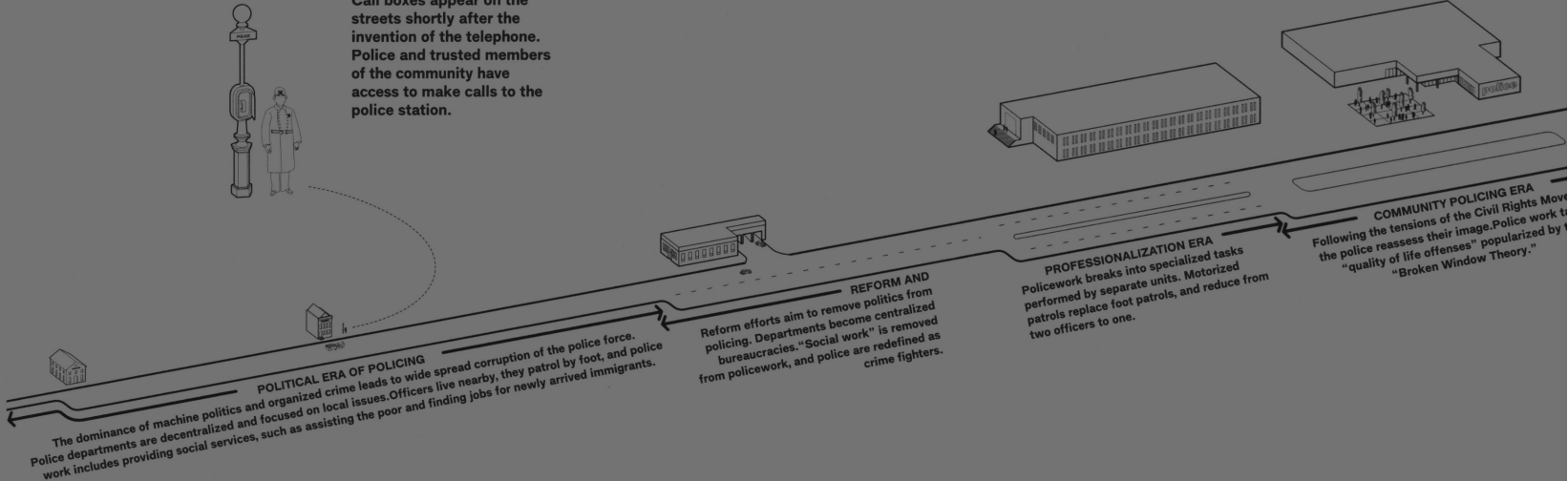

Polis Station: Six Design Principles

1. Expand Programming within the Station
2. Create Common Ground Around the Station
3. Open Access to Information
4. Extend Learning Opportunities into a Neighborhood Campus
5. Establish A Shared Wellness Network
6. Encourage Service Workers to Live Nearby

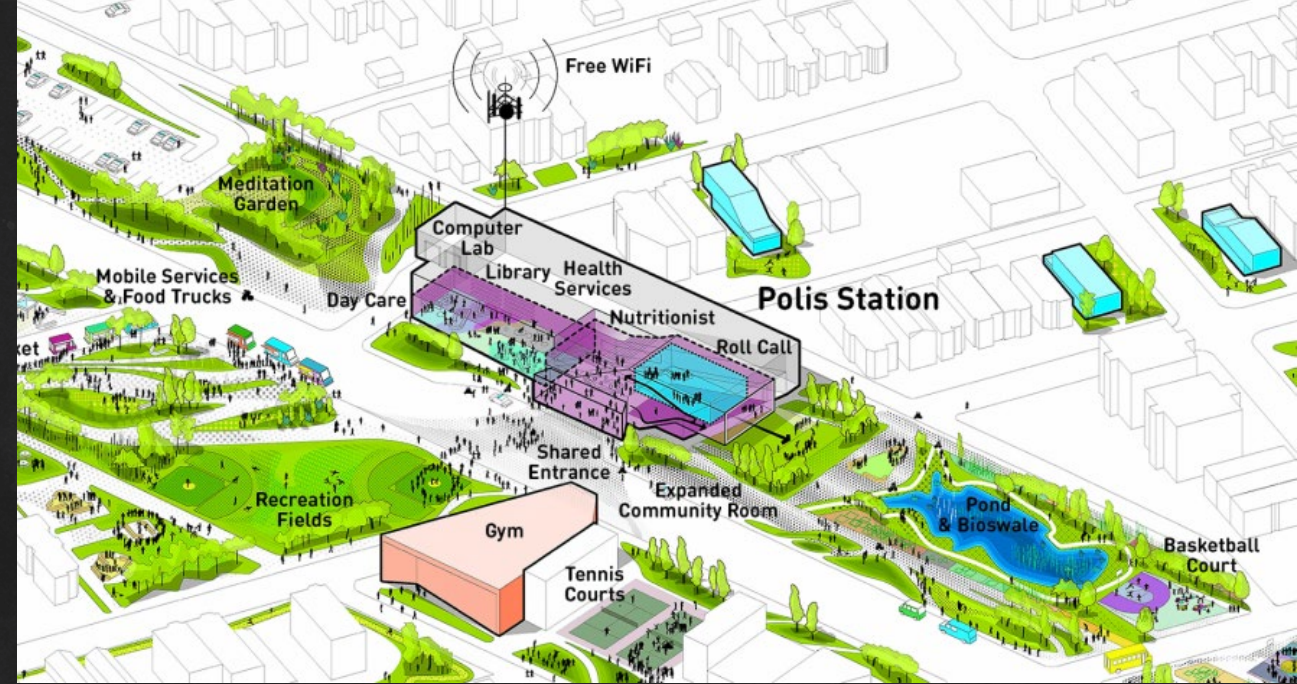

Polis Station: Six Design Principles

1. Expand Programming within the Station
2. Create Common Ground Around the Station
3. Open Access to Information
4. Extend Learning Opportunities into a Neighborhood Campus
5. Establish A Shared Wellness Network
6. Encourage Service Workers to Live Nearby

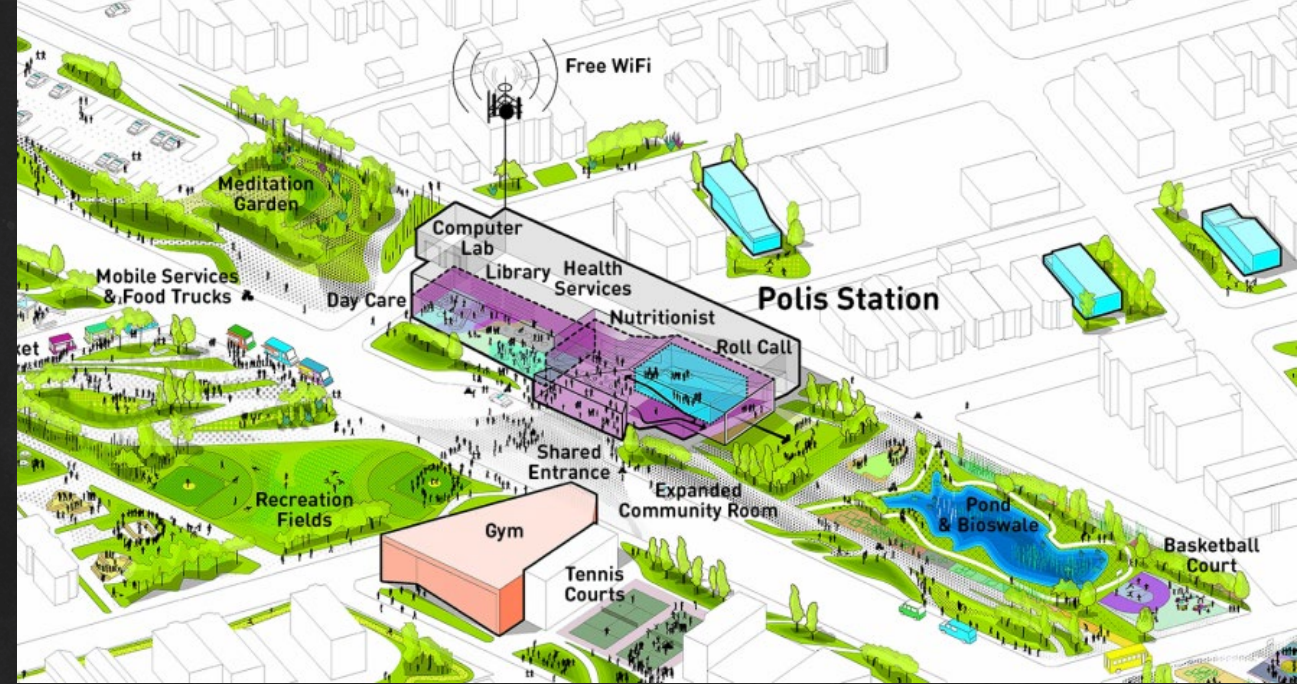

Polis Station: Six Design Principles

1. Expand Programming within the Station
2. Create Common Ground Around the Station
- 3. Open Access to Information**
4. Extend Learning Opportunities into a Neighborhood Campus
5. Establish A Shared Wellness Network
6. Encourage Service Workers to Live Nearby

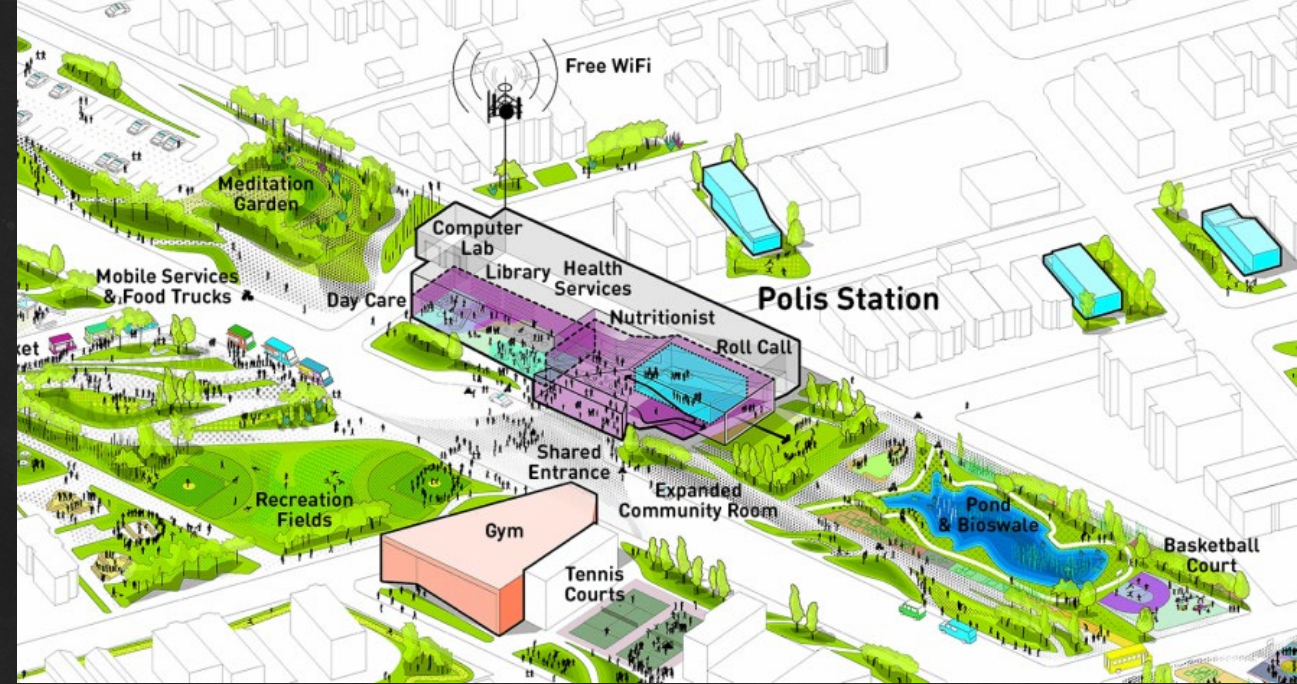

03: RESEARCH

Polis Station: Six Design Principles

1. Expand Programming within the Station
2. Create Common Ground Around the Station
3. Open Access to Information
4. Extend Learning Opportunities into a Neighborhood Campus
5. Establish A Shared Wellness Network
6. Encourage Service Workers to Live Nearby

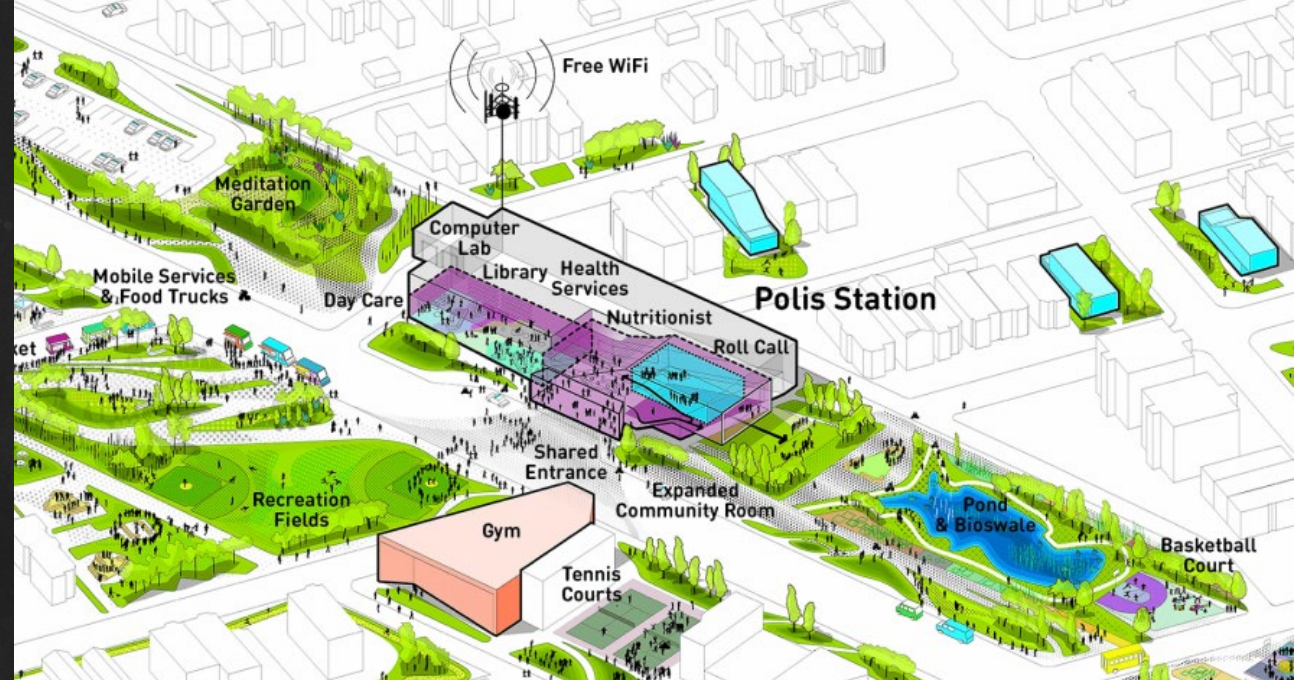

Polis Station: Six Design Principles

1. Expand Programming within the Station
2. Create Common Ground Around the Station
3. Open Access to Information
4. Extend Learning Opportunities into a Neighborhood Campus
5. Establish A Shared Wellness Network
6. Encourage Service Workers to Live Nearby

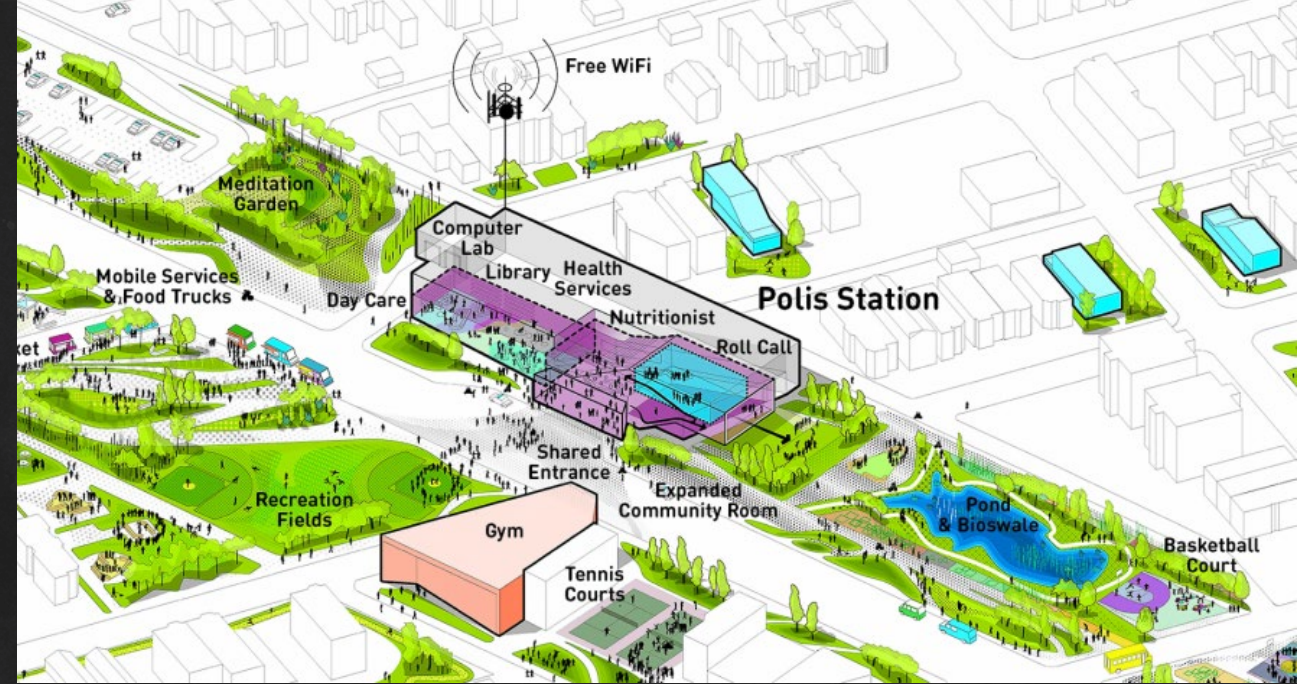

Polis Station: Six Design Principles

1. Expand Programming within the Station
2. Create Common Ground Around the Station
3. Open Access to Information
4. Extend Learning Opportunities into a Neighborhood Campus
5. Establish A Shared Wellness Network
6. Encourage Service Workers to Live Nearby

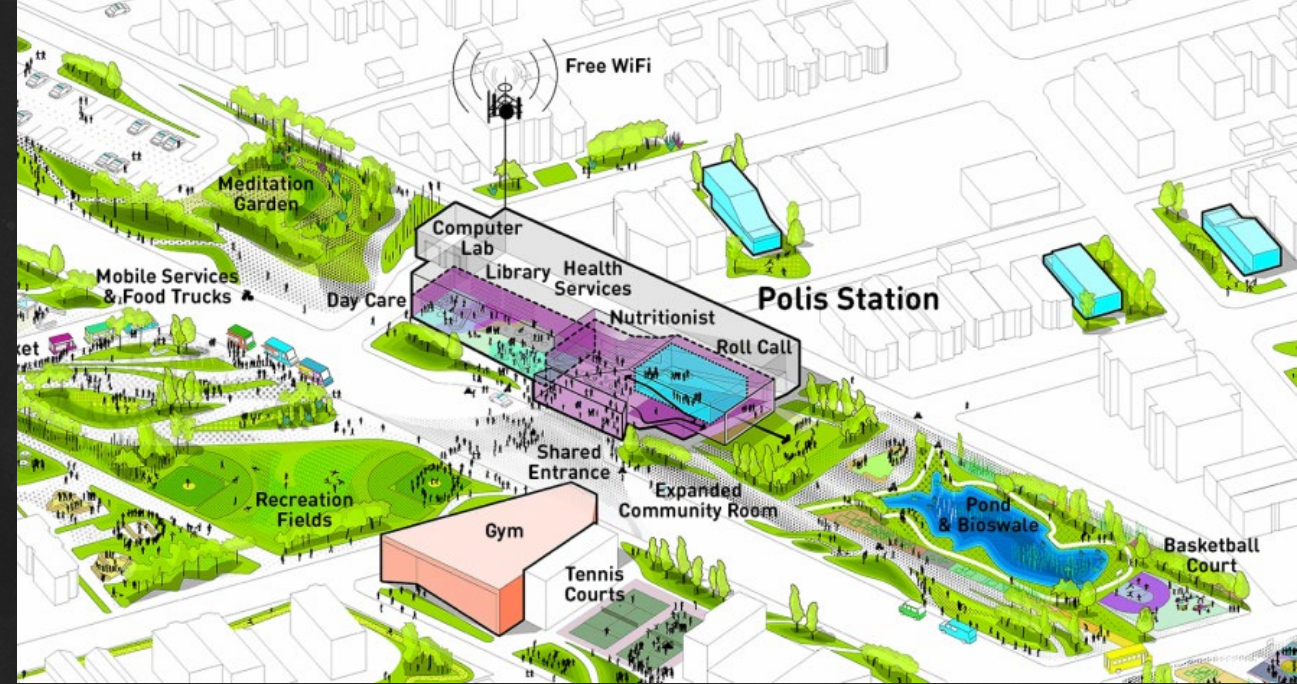

The psychology of justice buildings:

A survey experiment on police architecture, public sentiment, and race.

- 700 respondents
 - Black (238)
 - White (237)
 - Latino (225)
- Results:
 - Hostile architecture effects how the public perceive the police.
 - Public perception of the police goes beyond the facade of a building.



Rethinking the Police

Daniel Reinhardt

- Examines police culture and the need for reform
 - ‘Us vs. Them’ perspective
- Pushes for real community policing
- Encourages officers to engage with the community
 - Example: Volunteer Coaching

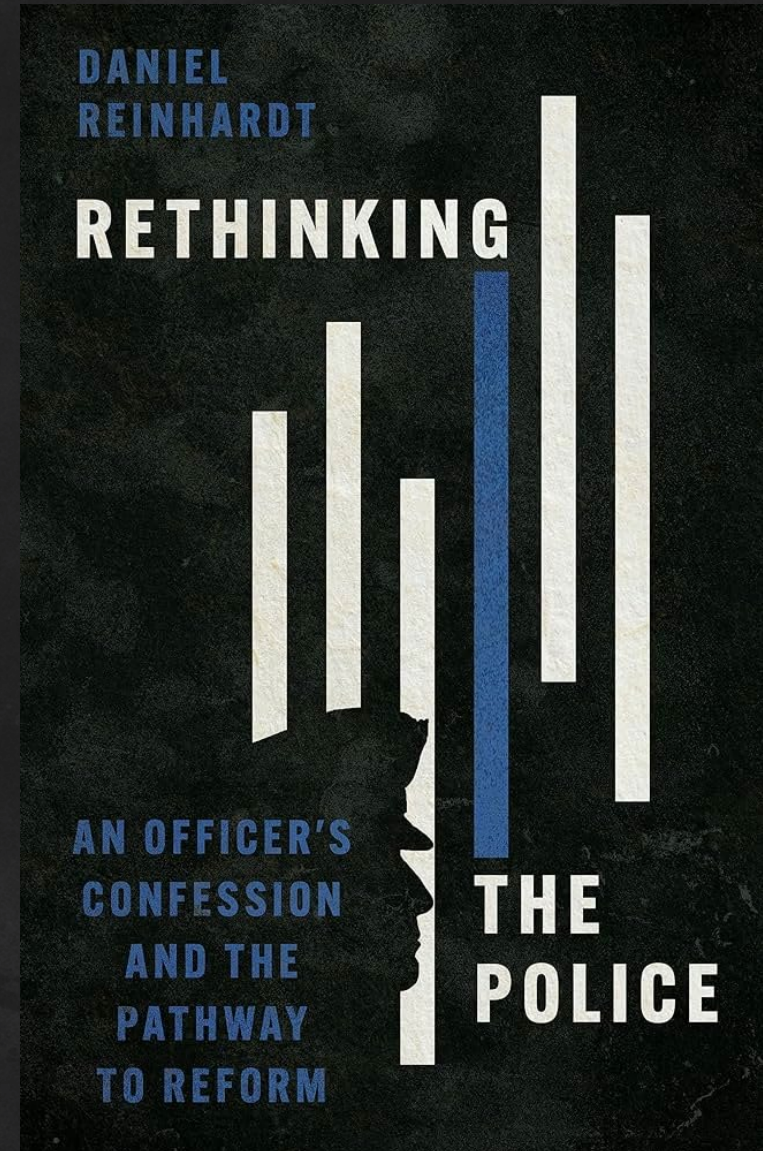

Case Study:

Community Spaces

NYPD 40th Precinct – BIG ARCHITECTS

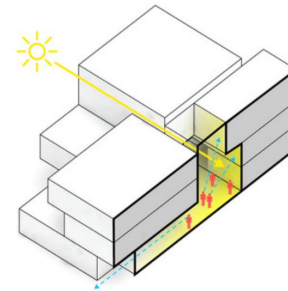

ATRIUM

program areas, entrances and circulation routes are oriented towards the central atrium. This allows for complete oversight from main desk while maintaining visual relationships between all users. Clerestory windows at the upper level bring daylight into the building's core.

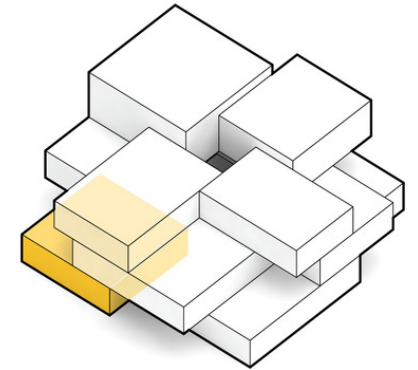

COMMUNITY

A separately accessible community room will be the first of its kind in the city. At the street-facing façade, small circular perforations in the concrete panels call attention to the special function of this particular programmatic block, allowing for transparency that is essential to the NYPD's plans for this new kind of public space.

Case Study:

Mass Timber Construction

Lincoln City Police Department – FFA



GOALS

1. Embrace Mixed-Use Typology.
2. Utilize Civic Assets For Community Campus
3. Leverage Mass-Timber Construction
4. Promote Healthy Interactions within Interior



George Floyd Protests

Minneapolis, MN

02: CONTEXT

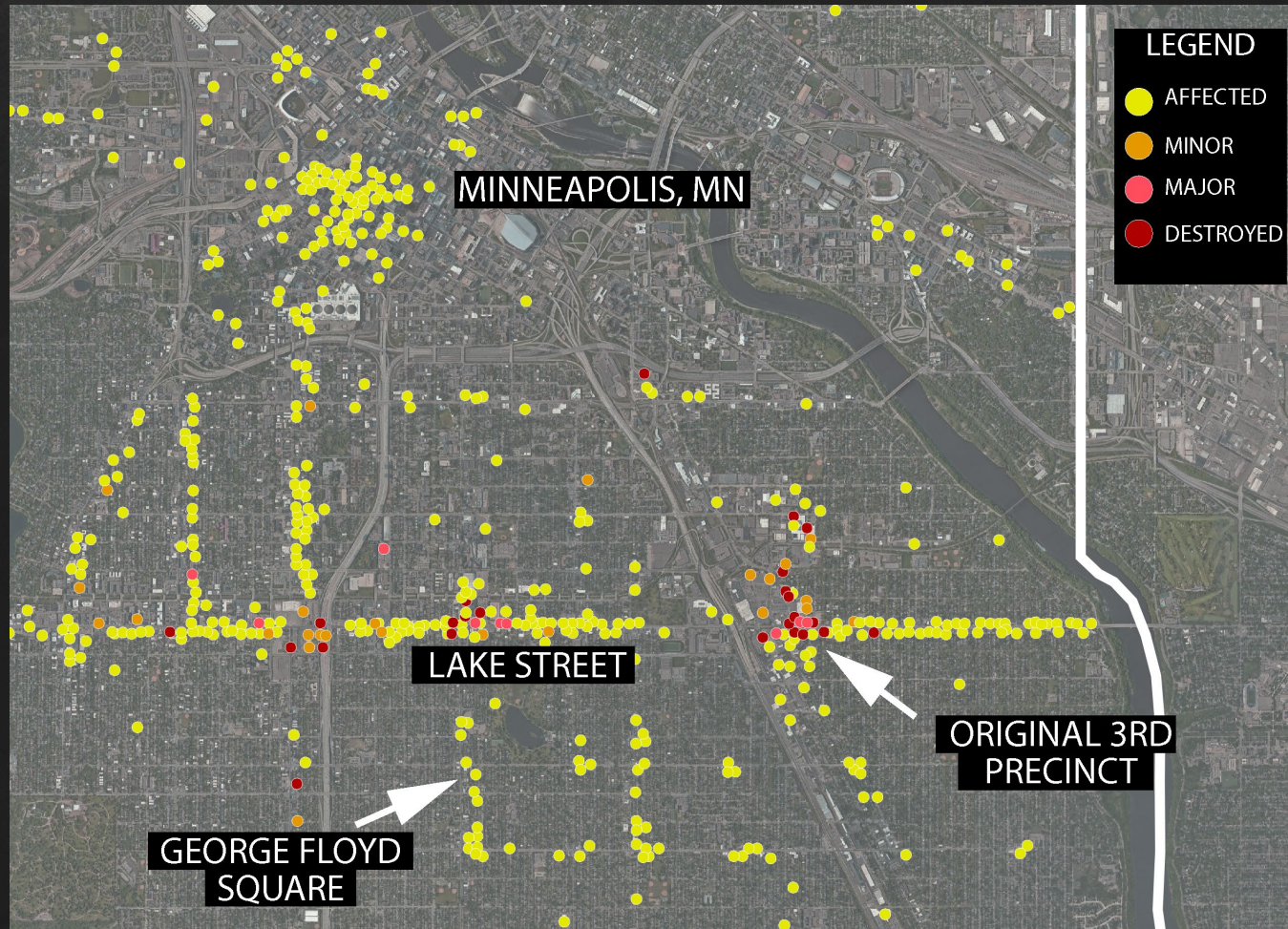

MINNEAPOLIS

For riot-damaged Twin Cities businesses, rebuilding begins with donations, pressure on government

Business owners assess damages, physical and emotional.

By Jeffrey Meitrodt Star Tribune | JUNE 6, 2020 — 8:03PM

Rebuilding after the protests

More than 400 businesses were damaged during the riots, with rebuilding costs estimated at more than \$500 million. Some of the worst damage took place on this stretch of Lake Street in Minneapolis.

MPD Third Precinct burns as protests continue following George Floyd's death

While most protests have been peaceful, some factions have left vandalism, fires and looting in their wake.

© KARE
Author: Tyler Cashman (KARE 11), Emily Haavik, Diane Sandberg (KARE11)

02: CONTEXT



MINNEAPOLIS

For riot-damaged Twin Cities businesses, rebuilding begins with donations, pressure on government

Business owners assess damages, physical and emotional.

By Jeffrey Meitrodt Star Tribune | JUNE 6, 2020 — 8:03PM

Rebuilding after the protests

More than 400 businesses were damaged during the riots, with rebuilding costs estimated at more than \$500 million. Some of the worst damage took place on this stretch of Lake Street in Minneapolis.



MPD Third Precinct burns as protests continue following George Floyd's death

While most protests have been peaceful, some factions have left vandalism, fires and looting in their wake.



©KARE
Author: Tyler Cashman (KARE 11), Emily Haavik, Diane Sandberg (KARE11)

02: SITE INTRODUCTION



02: SITE INTRODUCTION



02: SITE INTRODUCTION





There are two options:

1. Traditional Approach
2. Reimagine the Police Station

02: SITE INTRODUCTION



02: SITE INTRODUCTION



02: SITE INTRODUCTION



04: RESPONSE

RESPONSE

Minneapolis, MN



04: PROPOSAL



04: PROPOSAL

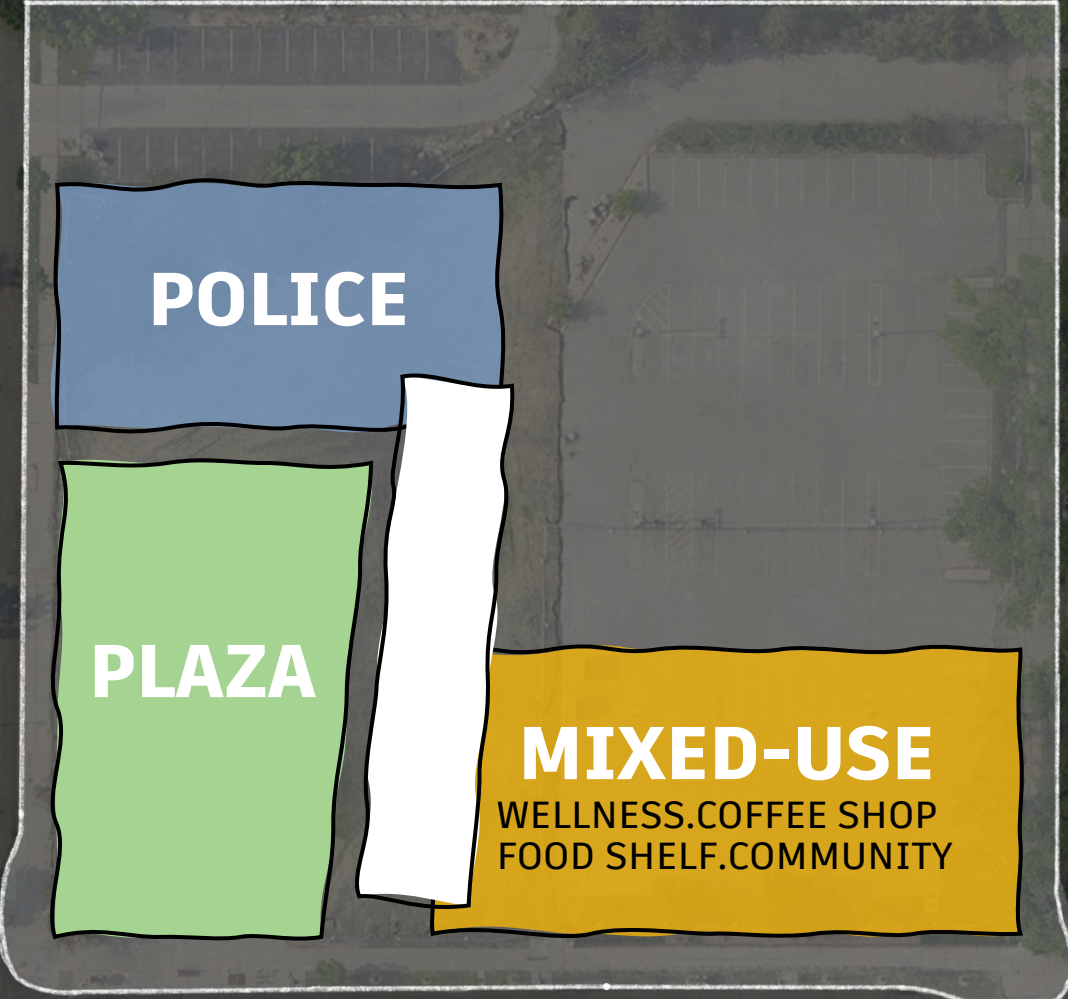

04: PROPOSAL

POLICE

PLAZA

**STILL DIVIDED BY
FUNCTION/FORM**

MIXED-USE
WELLNESS.COFFEE SHOP
FOOD SHELF.COMMUNITY

04: PROPOSAL

CENTRAL CORRIDOR



04: PROPOSAL

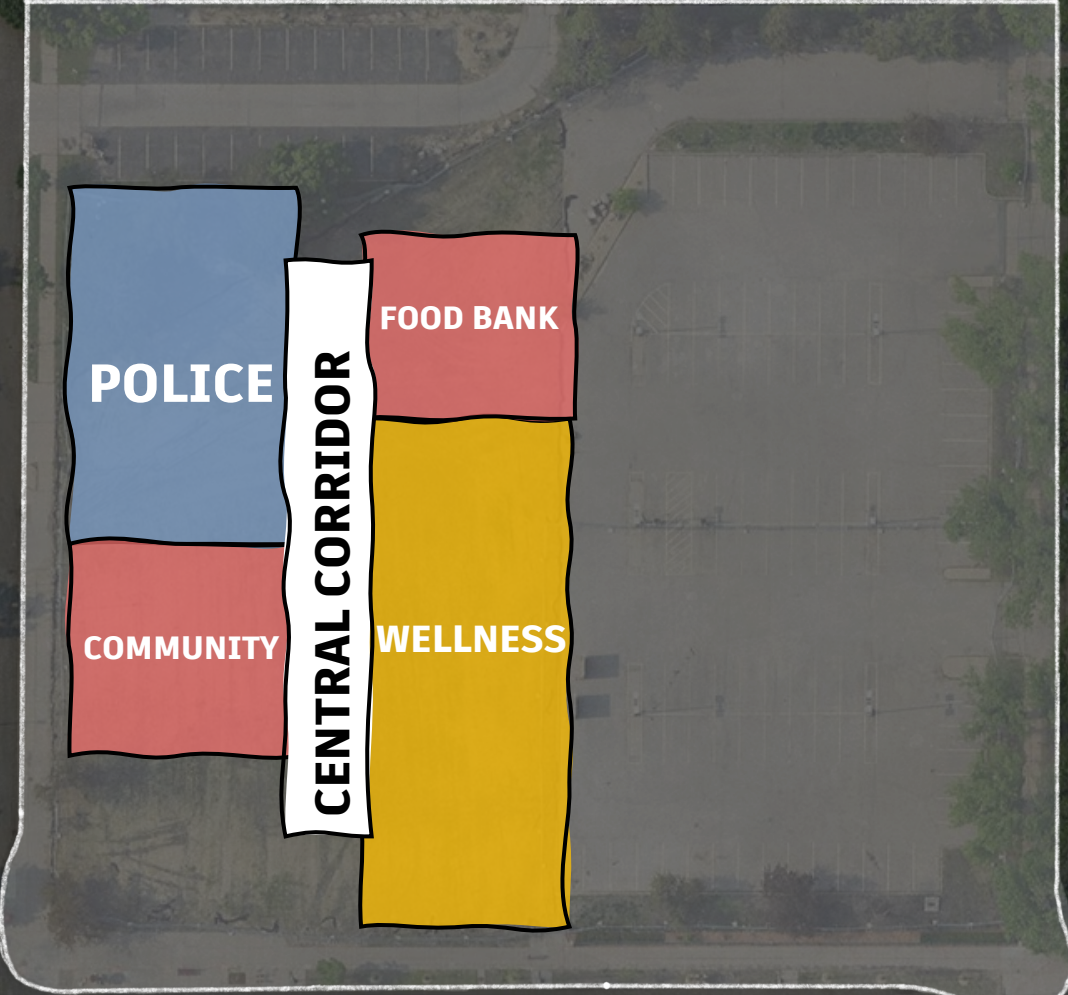

04: PROPOSAL

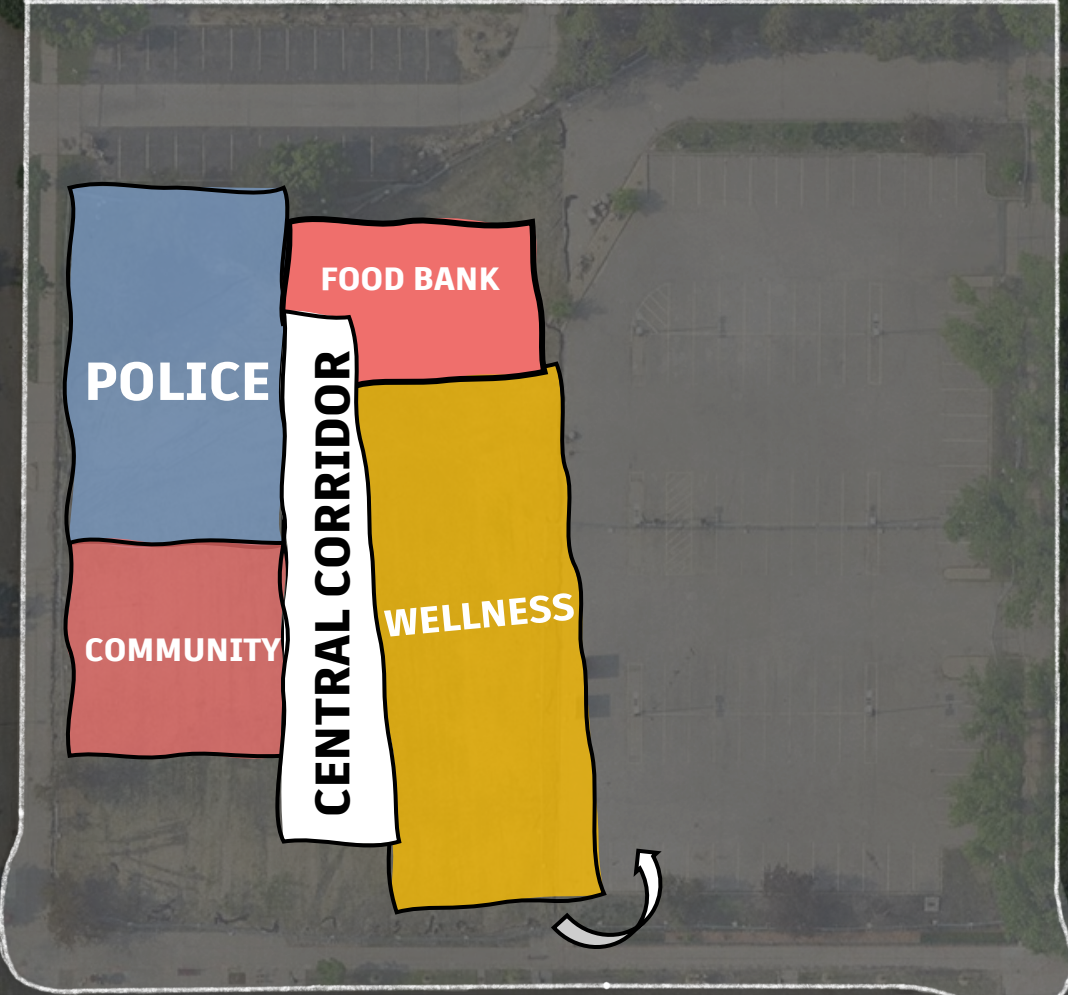

04: PROPOSAL

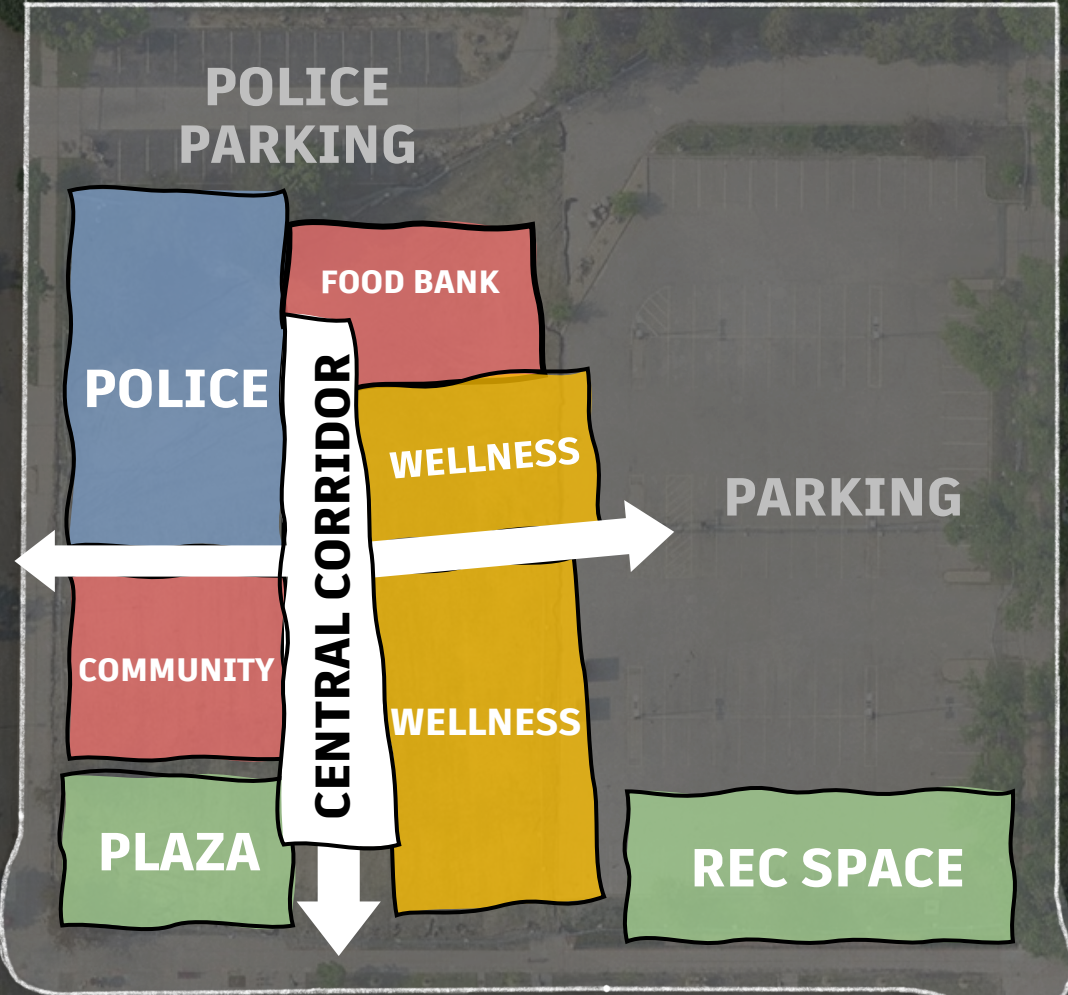

SHOPS

POLICE PARKING

POLICE

FOOD BANK

WELLNESS

PARKING

COMMUNITY

WELLNESS

PLAZA

CENTRAL CORRIDOR

REC SPACE



Site Plan

- ① Public Library
- ② Lake Street Shops
- ③ Public Plaza
- ④ Charter School
- ⑤ Community Mural
- ⑥ Outdoor Basketball Court
- ⑦ Playground
- ⑧ Parking
- ⑨ Secure Police Parking
- ⑩ Community Gardens
- ⑪ Residential Neighborhood

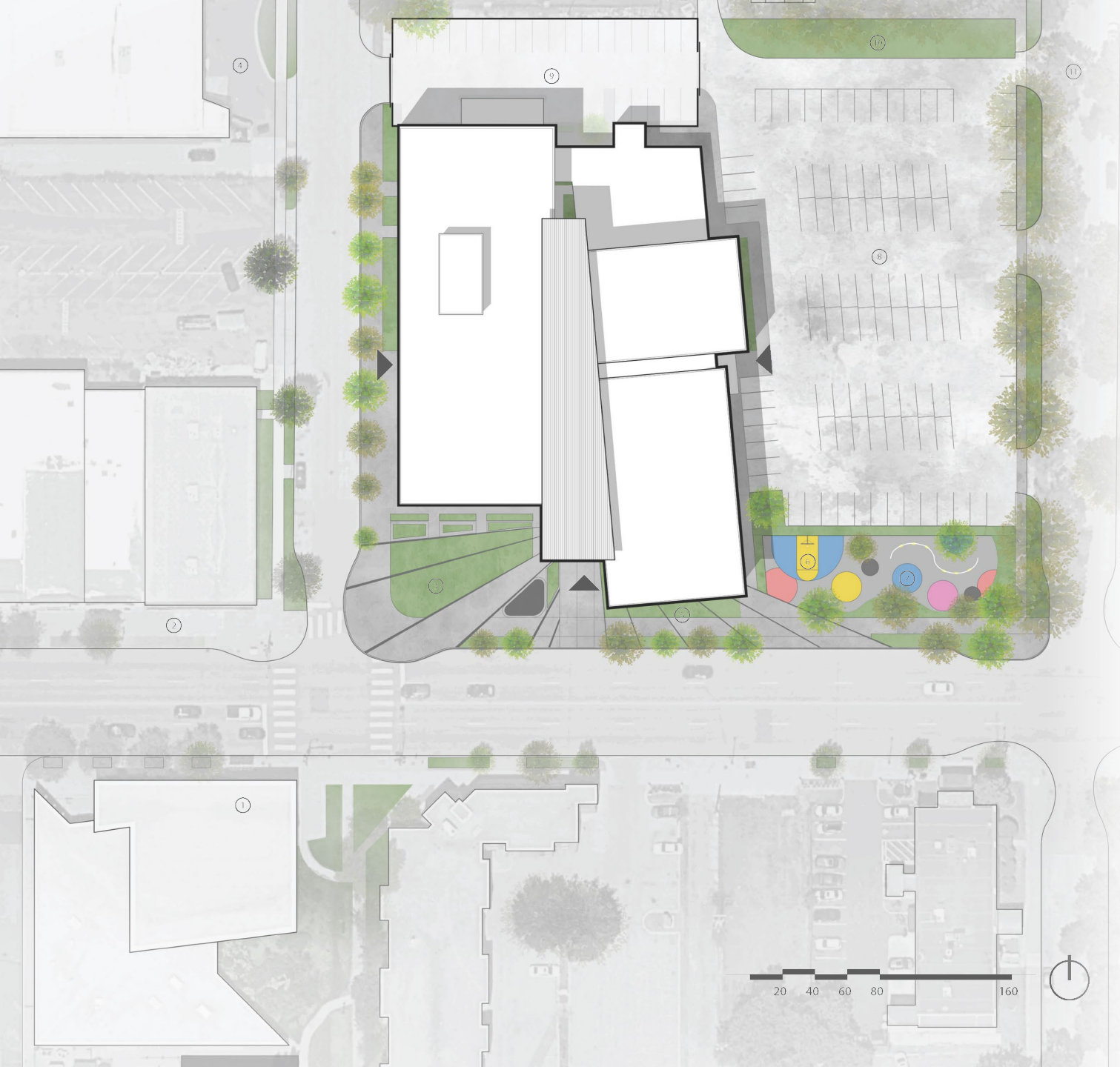

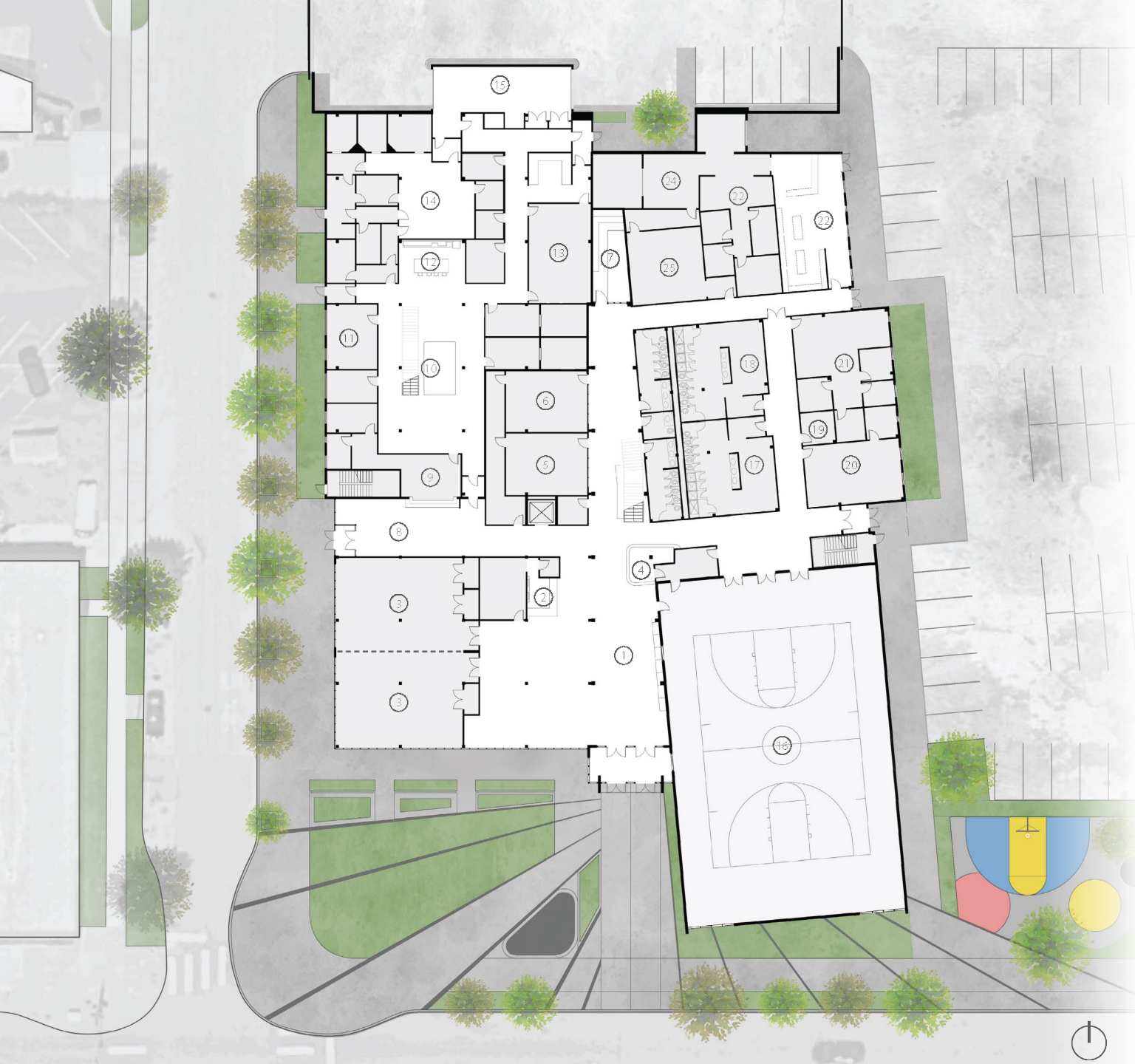

First Level Plan

Community

- ① Corridor Hall
- ② Cafe
- ③ Multi-Purpose Room(s)
- ④ Help Desk
- ⑤ E-Sports Lounge
- ⑥ Barbershop
- ⑦ Courtyard

Wellness

- ⑬ Gym
- ⑭ Men's Locker Rooms
- ⑮ Women's Locker Rooms
- ⑯ Family Locker Rooms
- ⑰ Mixed-use Room
- ⑱ Offices

Police

- ① Lobby
- ② Help Desk
- ③ Lounge
- ④ Offices
- ⑤ Kitchen
- ⑥ Conference Room
- ⑦ Booking/Holding
- ⑧ Sally Port

Food Bank

- ① Lobby
- ② Offices
- ③ Storage
- ④ Community Kitchen

PROGRAMMING

First Level Plan



Community

- ① Corridor Hall
- ② Cafe
- ③ Multi-Purpose Room(s)
- ④ Help Desk
- ⑤ E-Sports Lounge
- ⑥ Barbershop
- ⑦ Courtyard

Wellness

- ⑬ Gym
- ⑰ Men's Locker Rooms
- ⑱ Women's Locker Rooms
- ⑲ Family Locker Rooms
- ⑳ Mixed-use Room
- ㉑ Offices

Police

- ⑧ Lobby
- ⑨ Help Desk
- ⑩ Lounge
- ⑪ Offices
- ⑫ Kitchen
- ⑬ Conference Room
- ⑭ Booking/Holding
- ⑮ Sally Port

Food Bank

- ㉒ Lobby
- ㉓ Offices
- ㉔ Storage
- ㉕ Community Kitchen

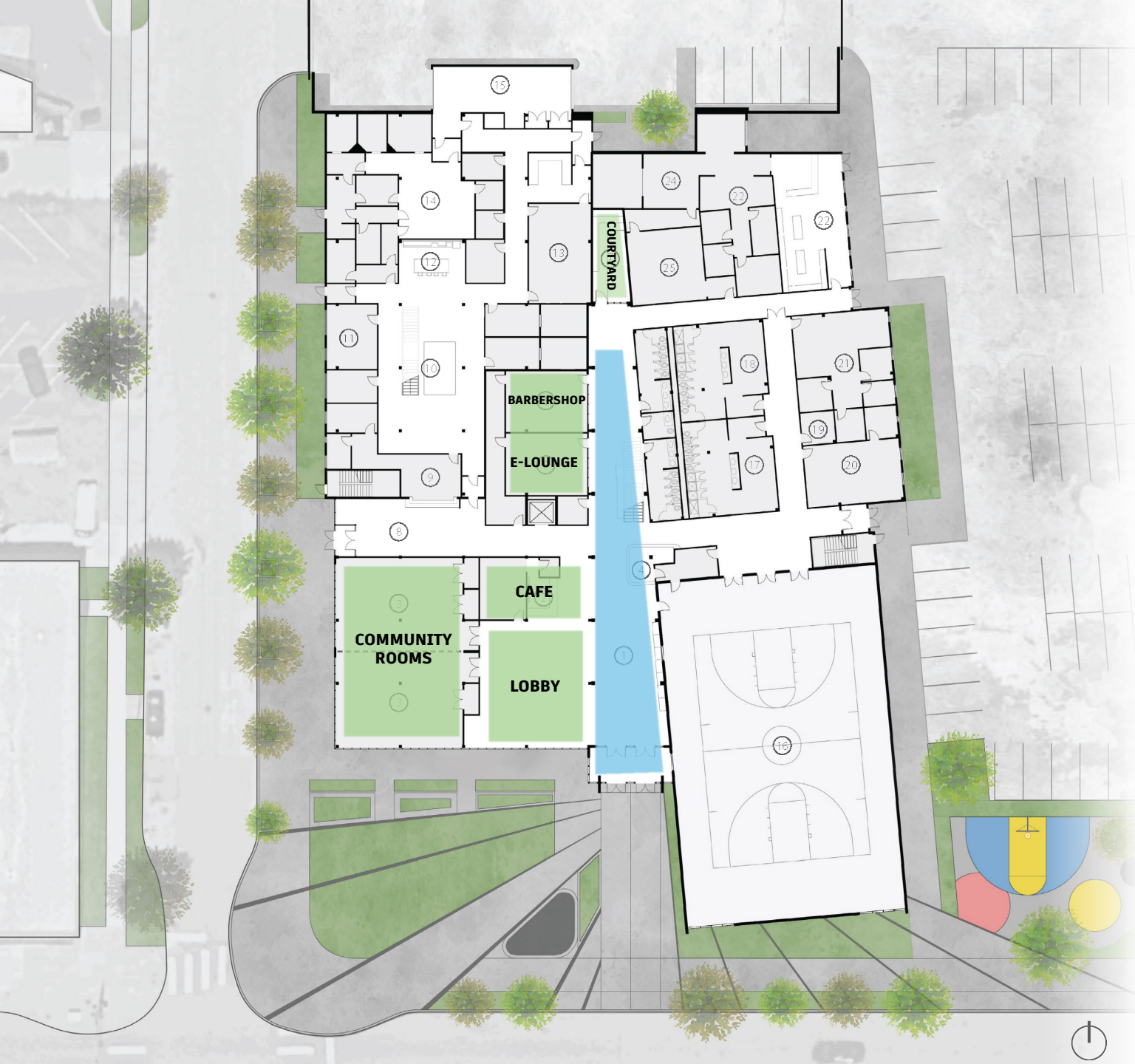

First Level Plan

Community

- ① Corridor Hall
- ② Cafe
- ③ Multi-Purpose Room(s)
- ④ Help Desk
- ⑤ E-Sports Lounge
- ⑥ Barbershop
- ⑦ Courtyard

Wellness

- ⑬ Gym
- ⑭ Men's Locker Rooms
- ⑮ Women's Locker Rooms
- ⑯ Family Locker Rooms
- ⑰ Mixed-use Room
- ⑱ Offices

Police

- ① Lobby
- ② Help Desk
- ③ Lounge
- ④ Offices
- ⑤ Kitchen
- ⑥ Conference Room
- ⑦ Booking/Holding
- ⑧ Sally Port

Food Bank

- ① Lobby
- ② Offices
- ③ Storage
- ④ Community Kitchen



Coffee in TIME

Coffee MENU

DIRECTORY

ESPORTS LOUNGE

WELCOME

CENTRAL HALL

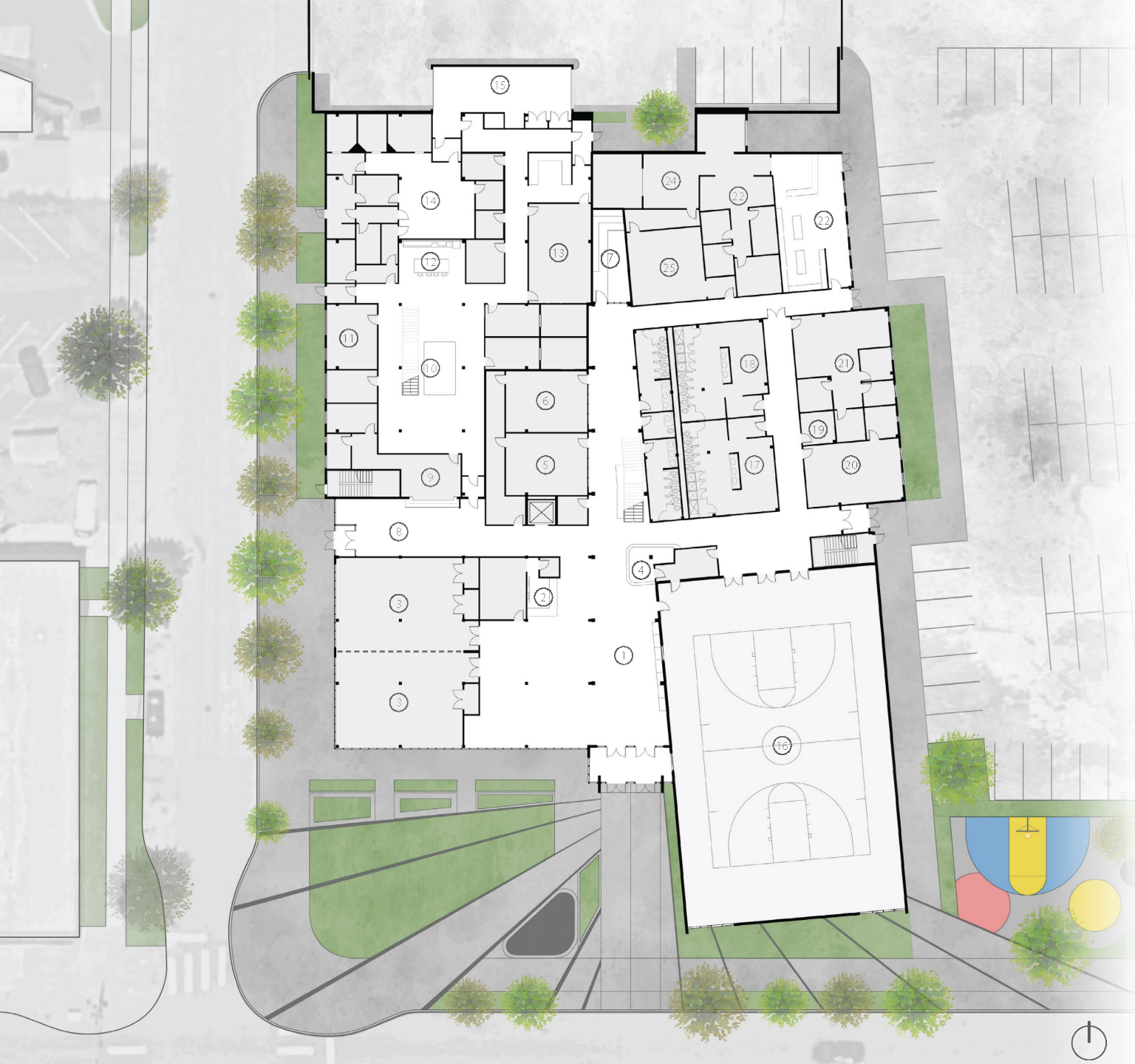

First Level Plan

Community

- ① Corridor Hall
- ② Cafe
- ③ Multi-Purpose Room(s)
- ④ Help Desk
- ⑤ E-Sports Lounge
- ⑥ Barbershop
- ⑦ Courtyard

Wellness

- ⑬ Gym
- ⑭ Men's Locker Rooms
- ⑮ Women's Locker Rooms
- ⑯ Family Locker Rooms
- ⑰ Mixed-use Room
- ⑱ Offices

Police

- ⑧ Lobby
- ⑨ Help Desk
- ⑩ Lounge
- ⑪ Offices
- ⑫ Kitchen
- ⑬ Conference Room
- ⑭ Booking/Holding
- ⑮ Sally Port

Food Bank

- ⑲ Lobby
- ⑳ Offices
- ㉑ Storage
- ㉒ Community Kitchen

First Level Plan

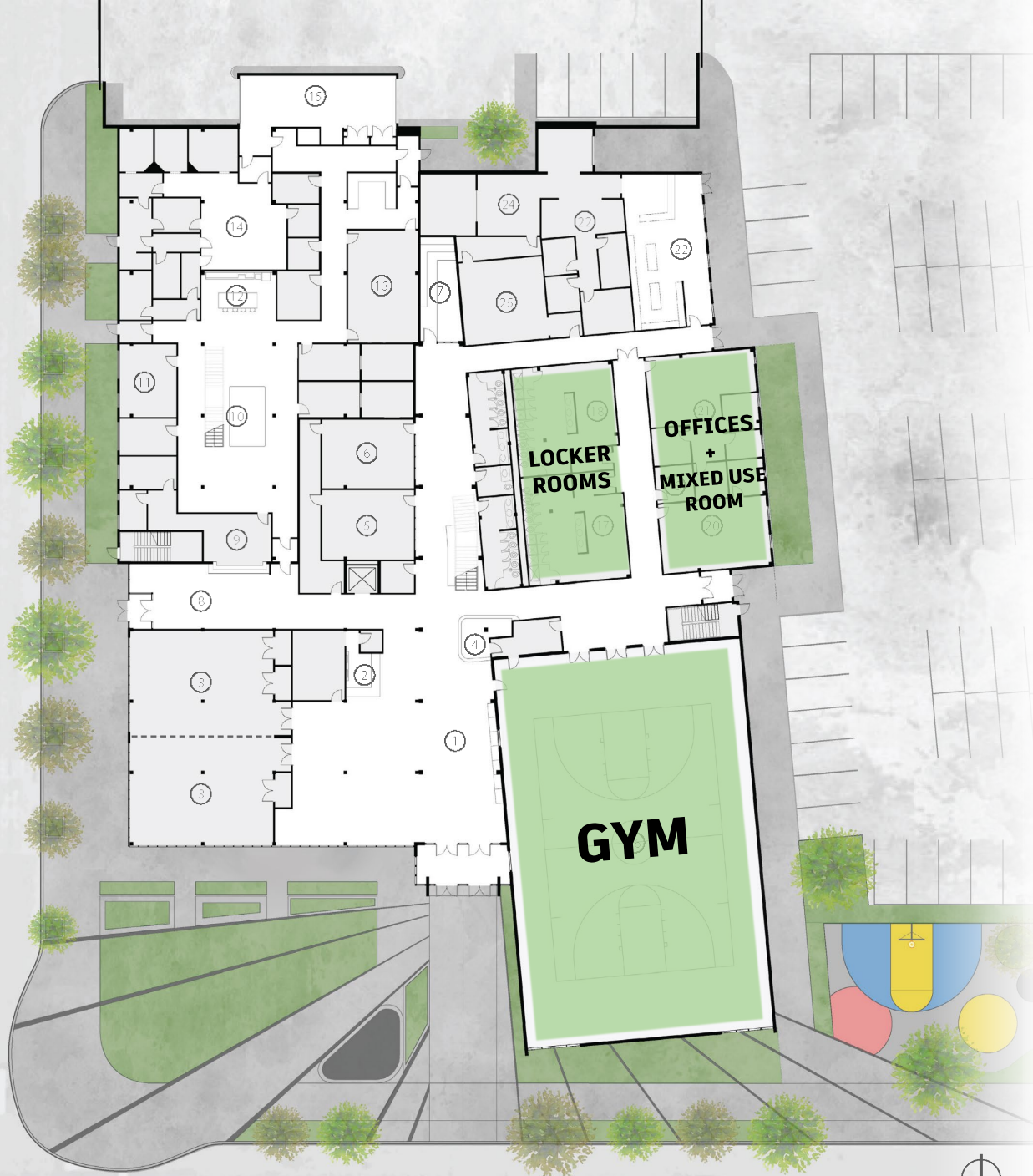

Community

- ① Corridor Hall
- ② Cafe
- ③ Multi-Purpose Room(s)
- ④ Help Desk
- ⑤ E-Sports Lounge
- ⑥ Barbershop
- ⑦ Courtyard

Wellness

- ⑬ Gym
- ⑭ Men's Locker Rooms
- ⑮ Women's Locker Rooms
- ⑯ Family Locker Rooms
- ⑰ Mixed-use Room
- ⑱ Offices

Police

- ⑧ Lobby
- ⑨ Help Desk
- ⑩ Lounge
- ⑪ Offices
- ⑫ Kitchen
- ⑬ Conference Room
- ⑭ Booking/Holding
- ⑮ Sally Port

Food Bank

- ⑲ Lobby
- ⑳ Offices
- ㉑ Storage
- ㉒ Community Kitchen

PROGRAMMING

First Level Plan



Community

- ① Corridor Hall
- ② Cafe
- ③ Multi-Purpose Room(s)
- ④ Help Desk
- ⑤ E-Sports Lounge
- ⑥ Barbershop
- ⑦ Courtyard

Wellness

- ⑬ Gym
- ⑭ Men's Locker Rooms
- ⑮ Women's Locker Rooms
- ⑯ Family Locker Rooms
- ⑰ Mixed-use Room
- ⑱ Offices

Police

- ⑧ Lobby
- ⑨ Help Desk
- ⑩ Lounge
- ⑪ Offices
- ⑫ Kitchen
- ⑬ Conference Room
- ⑭ Booking/Holding
- ⑮ Sally Port

Food Bank

- ⑲ Lobby
- ⑳ Offices
- ㉑ Storage
- ㉒ Community Kitchen



HELP DESK



POLICE STATION LOBBY

PROGRAMMING

First Level Plan



Community

- ① Corridor Hall
- ② Cafe
- ③ Multi-Purpose Room(s)
- ④ Help Desk
- ⑤ E-Sports Lounge
- ⑥ Barbershop
- ⑦ Courtyard

Wellness

- ⑬ Gym
- ⑭ Men's Locker Rooms
- ⑮ Women's Locker Rooms
- ⑯ Family Locker Rooms
- ⑰ Mixed-use Room
- ⑱ Offices

Police

- ① Lobby
- ② Help Desk
- ③ Lounge
- ④ Offices
- ⑤ Kitchen
- ⑥ Conference Room
- ⑦ Booking/Holding
- ⑧ Sally Port

Food Bank

- ① Lobby
- ② Offices
- ③ Storage
- ④ Community Kitchen

PROGRAMMING

First Level Plan



Community

- ① Corridor Hall
- ② Cafe
- ③ Multi-Purpose Room(s)
- ④ Help Desk
- ⑤ E-Sports Lounge
- ⑥ Barbershop
- ⑦ Courtyard

Wellness

- ⑬ Gym
- ⑭ Men's Locker Rooms
- ⑮ Women's Locker Rooms
- ⑯ Family Locker Rooms
- ⑰ Mixed-use Room
- ⑱ Offices

Police

- ⑧ Lobby
- ⑨ Help Desk
- ⑩ Lounge
- ⑪ Offices
- ⑫ Kitchen
- ⑬ Conference Room
- ⑭ Booking/Holding
- ⑮ Sally Port

Food Bank

- ⑲ Lobby
- ⑳ Offices
- ㉑ Storage
- ㉒ Community Kitchen



POLICE LOUNGE

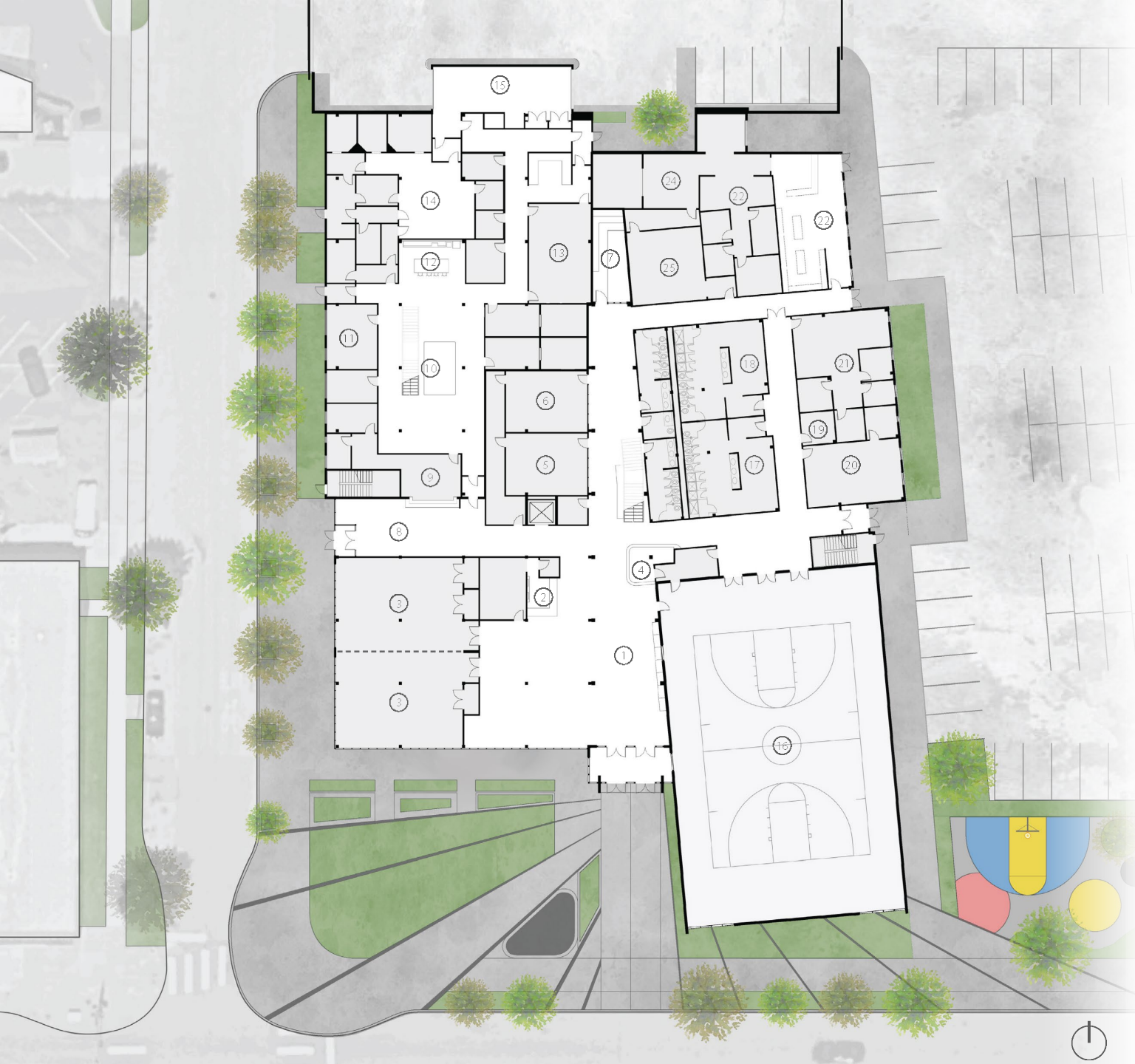

First Level Plan

Community

- ① Corridor Hall
- ② Cafe
- ③ Multi-Purpose Room(s)
- ④ Help Desk
- ⑤ E-Sports Lounge
- ⑥ Barbershop
- ⑦ Courtyard

Wellness

- ⑬ Gym
- ⑭ Men's Locker Rooms
- ⑮ Women's Locker Rooms
- ⑯ Family Locker Rooms
- ⑰ Mixed-use Room
- ⑱ Offices

Police

- ⑧ Lobby
- ⑨ Help Desk
- ⑩ Lounge
- ⑪ Offices
- ⑫ Kitchen
- ⑬ Conference Room
- ⑭ Booking/Holding
- ⑮ Sally Port

Food Bank

- ⑲ Lobby
- ⑳ Offices
- ㉑ Storage
- ㉒ Community Kitchen

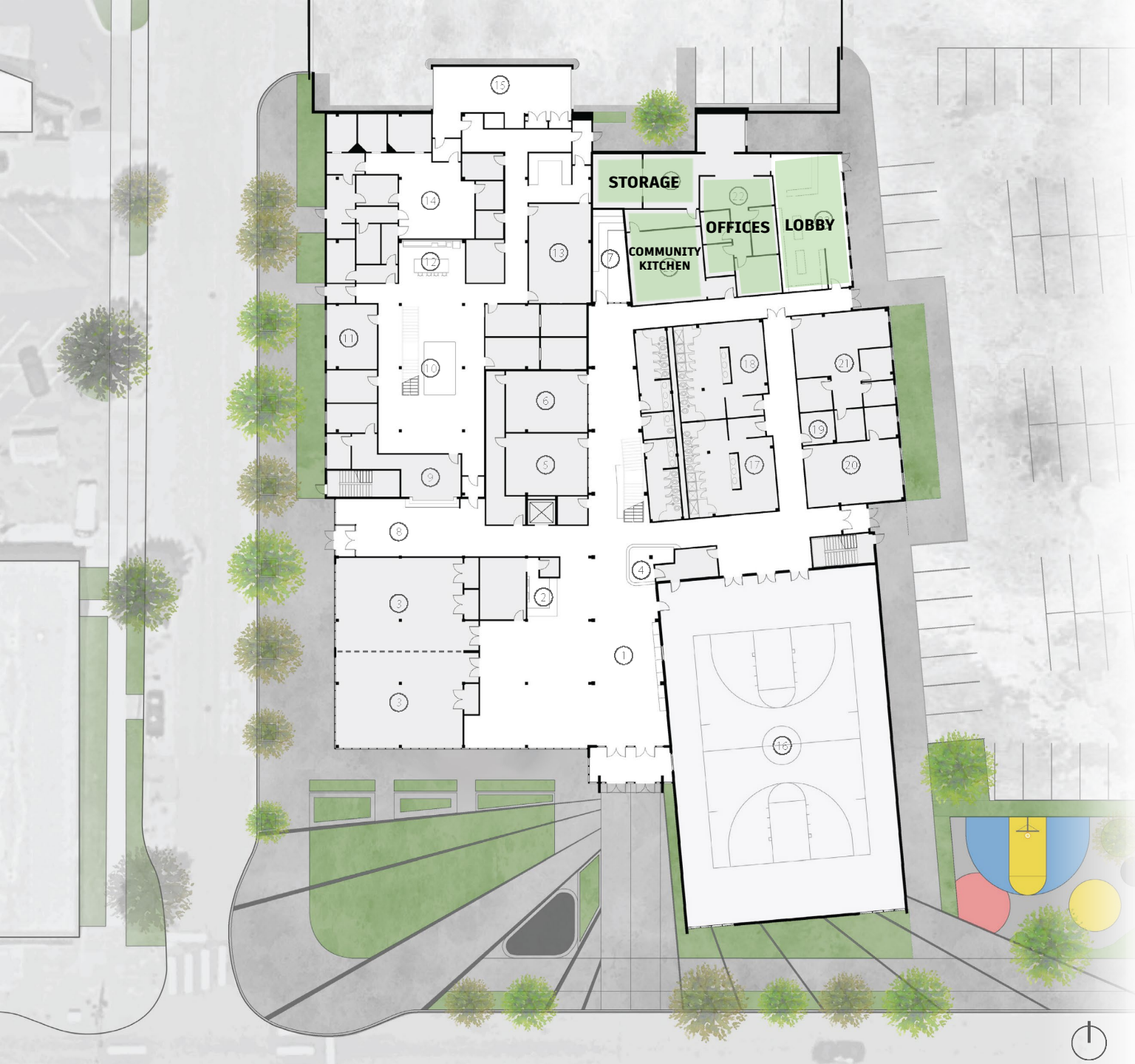

First Level Plan

Community

- ① Corridor Hall
- ② Cafe
- ③ Multi-Purpose Room(s)
- ④ Help Desk
- ⑤ E-Sports Lounge
- ⑥ Barbershop
- ⑦ Courtyard

Wellness

- ⑬ Gym
- ⑭ Men's Locker Rooms
- ⑮ Women's Locker Rooms
- ⑯ Family Locker Rooms
- ⑰ Mixed-use Room
- ⑱ Offices

Police

- ⑧ Lobby
- ⑨ Help Desk
- ⑩ Lounge
- ⑪ Offices
- ⑫ Kitchen
- ⑬ Conference Room
- ⑭ Booking/Holding
- ⑮ Sally Port

Food Bank

- ⑲ Lobby
- ⑳ Offices
- ㉑ Storage
- ㉒ Community Kitchen

Second Level Plan

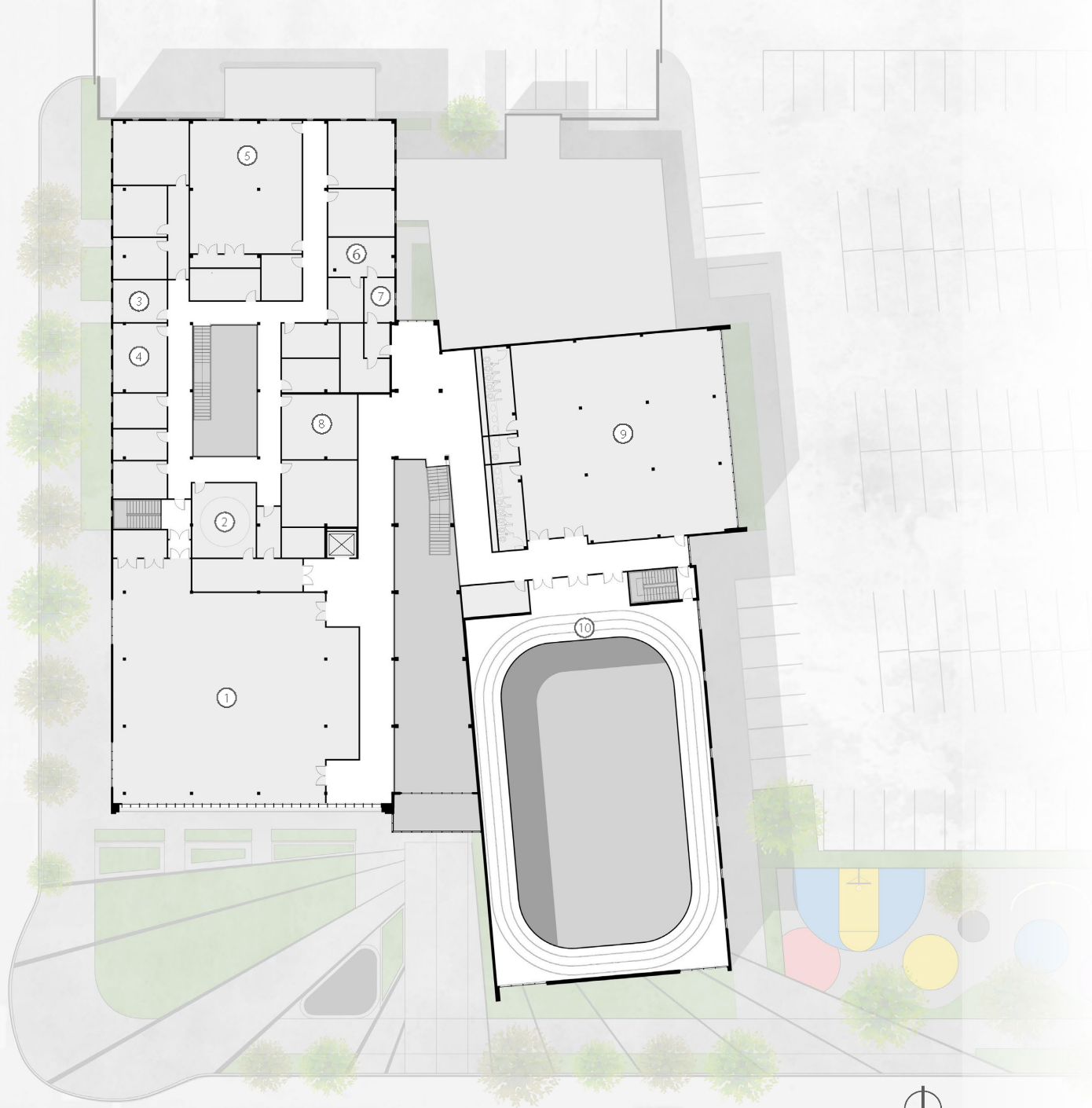

Police

- ② Relaxation Suite
- ③ Office
- ④ Open Offices
- ⑤ EOC/Training Room
- ⑥ Investigations Division
- ⑦ Interview Suite
- ⑧ Storage

Community

- ① Auditorium

Wellness

- ⑨ Fitness
- ⑩ Gym Track

Second Level Plan

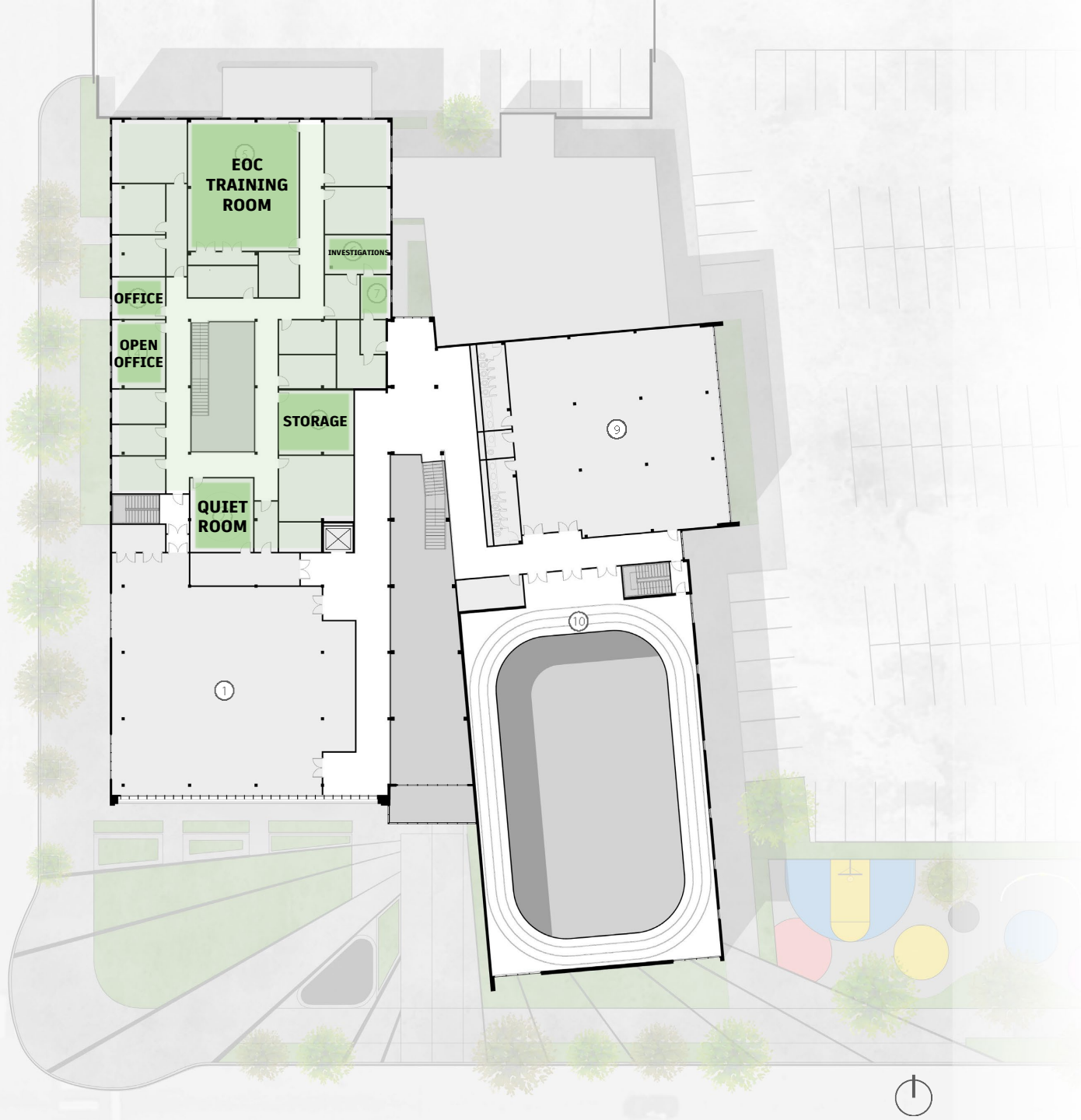

Police

- ② Relaxation Suite
- ③ Office
- ④ Open Offices
- ⑤ EOC/Training Room
- ⑥ Investigations Division
- ⑦ Interview Suite
- ⑧ Storage

Community

- ① Auditorium

Wellness

- ⑨ Fitness
- ⑩ Gym Track

Second Level Plan

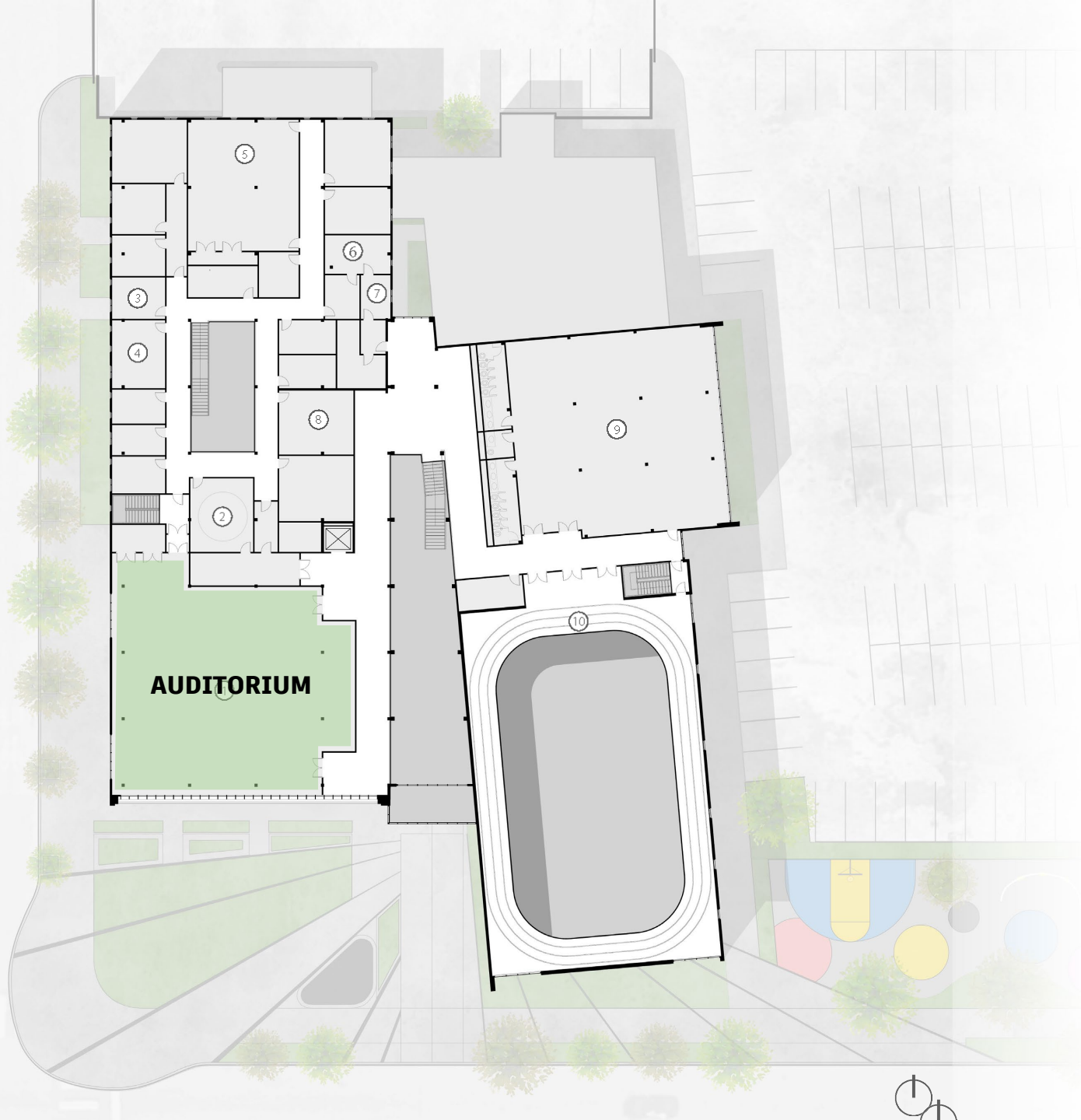

Police

- ② Relaxation Suite
- ③ Office
- ④ Open Offices
- ⑤ EOC/Training Room
- ⑥ Investigations Division
- ⑦ Interview Suite
- ⑧ Storage

Wellness

- ⑨ Fitness
- ⑩ Gym Track

Community

- ① Auditorium

Second Level Plan



Police

- ② Relaxation Suite
- ③ Office
- ④ Open Offices
- ⑤ EOC/Training Room
- ⑥ Investigations Division
- ⑦ Interview Suite
- ⑧ Storage

Community

- ① Auditorium

Wellness

- ⑨ Fitness
- ⑩ Gym Track



GYM TRACK

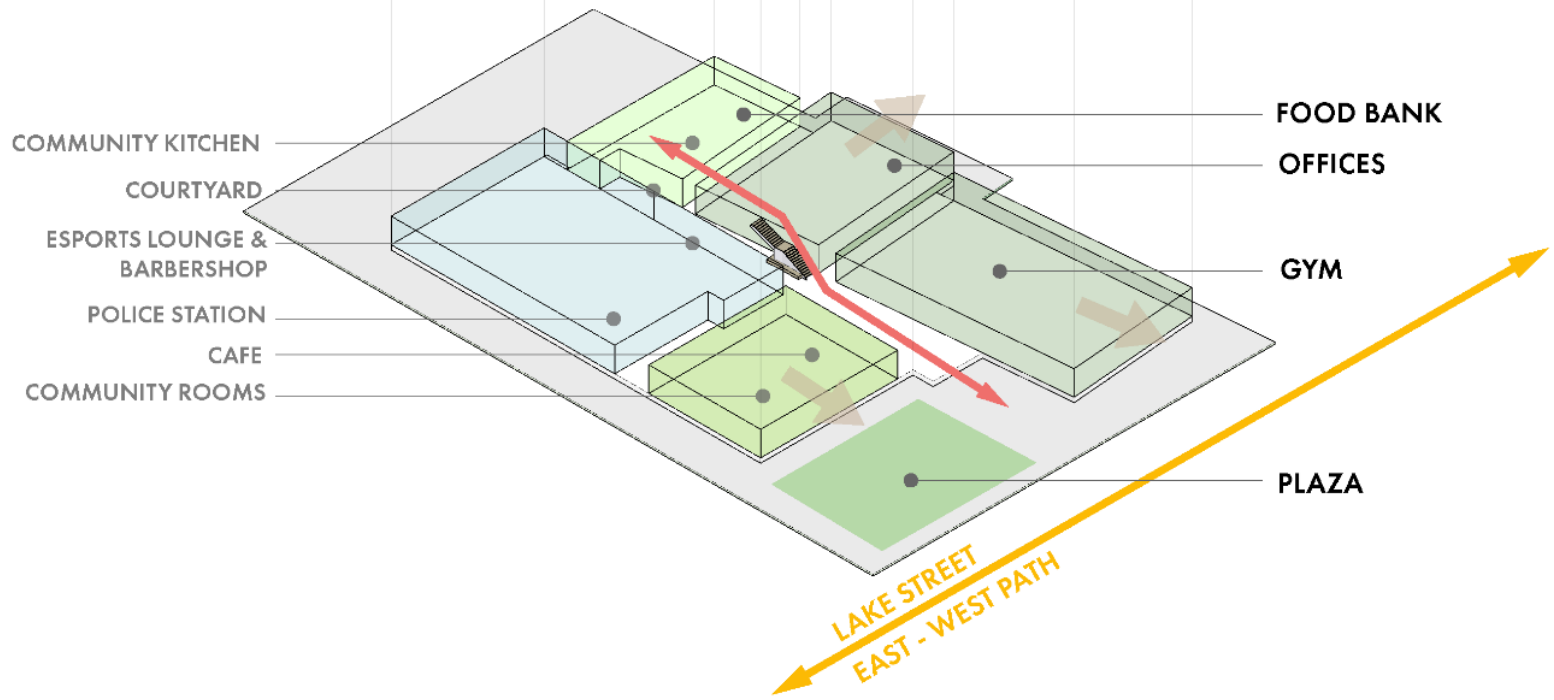
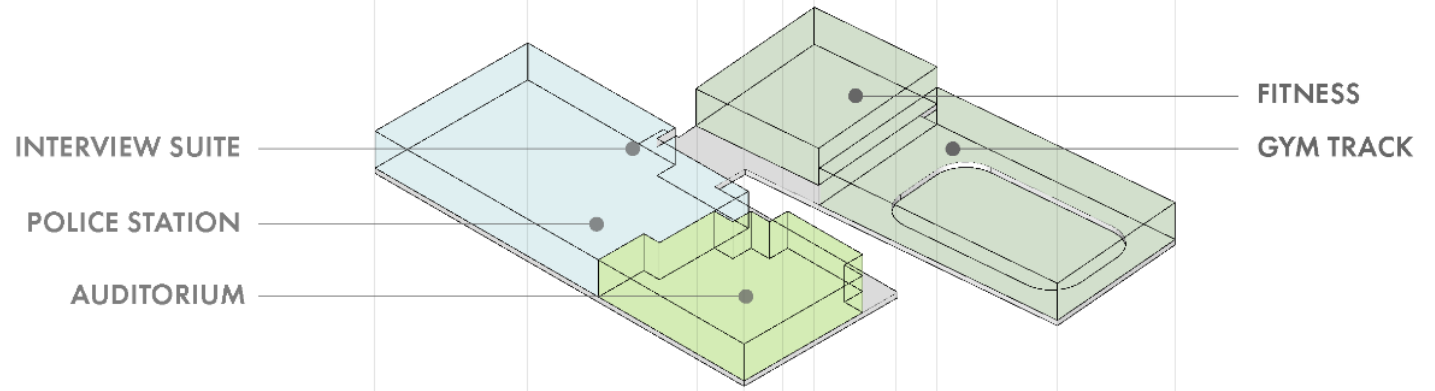

04: FUTURE RESEARCH

1. User-Centered Design Through Interviews
2. Integration of Mental Health Services
3. Optimal Site Location

Overview

01

Intro

**Problem
Background
Thesis Premise**

02

Research

**Research
Key Takeaways
Goals**

03

Context

**Site Introduction
Analysis**

04

Response

**Proposal
Key Concepts
Future Research**

“Architecture can’t force people to connect; it can only plan the crossing points, remove barriers, and make the meeting places useful and attractive.”

Denise Scott Brown



THANK YOU

questions, comments, etc.





THANK YOU

questions, comments, etc.

